

No. 118

Feature Article ..... 1-5

Energy-Efficient Solutions ..... 2



## PowerWise<sup>®</sup> Class G versus Class AB Headphone Amplifiers

— By Richard Gomez, Audio Product Engineer

Today's portable devices present many challenges ranging from output power to maintaining high levels of efficiency. As devices continue to become more feature rich, consumers will continue to demand higher levels of performance along with minimal battery power consumption, putting further emphasis on proper design of key components such as the headphone amplifiers. Headphone amplifiers are migrating from Class AB to Class G technology. The differences and design advantages of each technology will be addressed in this article.

### Class AB Headphone Amplifiers

Class AB is a compromise between Class A and Class B output stage topologies. A Class A output stage operates with both transistors biased in their active regions, and the low-side transistor constantly biased to handle peak load currents at all times. A Class B output stage operates with only one transistor active at a time, improving efficiency, but at the cost of distortion. The Class AB output stage is a compromise between Class A and Class B. Both output devices (push-pull) conduct for a little more than 180° but much less than 360°. The amount of bias current varies for each amplifier, but is a balance between minimal crossover distortion and yet good efficiency.

A simplified Class AB output stage is shown below (*Figure 1*). Each output device is biased such that they are both “on” at or near the zero crossing of the output signal, reducing crossover distortion but also lowering efficiency.

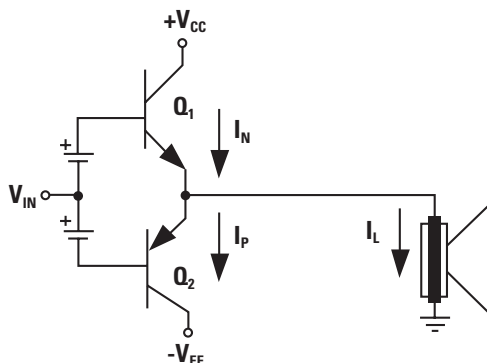

Figure 1. Simplified Class AB Output Stage

Each output device is biased such that they are both “on” at or near the zero crossing of the output signal, reducing crossover distortion but also lowering efficiency.

In *Figure 2*, the current waveform for a Class AB output stage. The left axis is the emitter currents through Q1 and Q2. The bias current  $I_Q$  flows through both Q1 and Q2 so that each device conducts for more than 180°. Around the crossover



# Extend Battery Life

- ✓ More features in a smaller space
- ✓ Richer audio & video
- ✓ Enhanced user experience



## National's PowerWise® solutions provide optimal performance at the lowest power

- **Adaptive Voltage Scaling (AVS) technology** reduces energy consumption in digital subsystems via a closed-loop voltage scaling to automatically minimize active and leakage power with minimal system overhead
- **Adaptive RF Power** enables energy savings in handsets by monitoring the RF power output and dynamically adjusting the supply voltage to RF PA
- **RGB LED backlighting** enhances color clarity while lowering power consumption
- **Mobile Pixel Link (MPL)** reduces EMI and interconnect while lowering power consumption
- **Integrated Class D audio subsystems** feature low-noise and very low quiescent current for minimum power consumption
- **Analog Noise Reduction Technology** reduces background noise and delivers more natural-sounding voice quality at one-tenth the power of DSP solutions



Find PowerWise products, metrics,  
white papers, app notes and tools at:  
[national.com/powerwise](http://national.com/powerwise)



## PowerWise® Class G versus Class AB Headphone Amplifiers

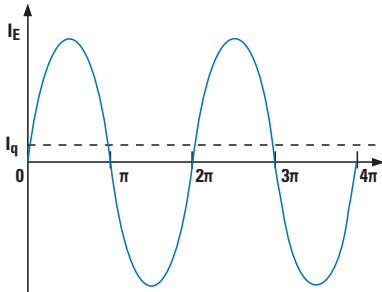

**Figure 2. Current Waveform for a Class AB Output Stage**

area, both transistors will be “on,” which greatly reduces the distortion inherent in Class B. Class AB does not fully eliminate crossover distortion but does reduce it to an acceptable level.

For Class B, the maximum efficiency is  $\pi/4$  or 78.5%. Class AB will have the same maximum efficiency if the Q current in the output stage is not taken into account. Taking the Q current into account lowers the maximum efficiency. The amount of change in the efficiency depends on the amount of Q current. A general equation will not be derived as real transistors with saturation voltages and  $I \times R$  loss contribute more to reduced efficiency than Q current.

Class AB power dissipation rises as amplifier output power increases, and peaks below maximum amplifier output power. Then it drops even though amplifier output power continues to increase. Class AB peak power dissipation occurs at 50% efficiency, when the amplifier output power is equal to the power dissipation. Peak power dissipation, PD<sub>MAX</sub>, for a mono, single-ended Class AB amplifier is found using the derived formula:

$$PD_{MAX} = \frac{(Total\ Supply\ Voltage)^2}{(2\pi^2RL)\ (Watts)}$$

The amount of power dissipation is inversely proportional to the load impedance. If the load impedance is halved, the peak power dissipation doubles. The amount of power dissipation increases with the square of the supply voltage. Doubling the supply voltage will increase the peak power dissipation by four times.

### Class G

The Class G topology is a modification of another Class of amplifier (normally Class B or Class AB) to increase efficiency and reduce power dissipation. Class G takes advantage of the fact that musical and voice signals have a high crest factor with most of the signal content at lower amplitudes. The Class G topology uses multiple power supplies, operating from the power rail that provides the optimum combination of headroom and power dissipation.

The Class G topology improves amplifier efficiency by optimizing the power supply. A Class G device uses a minimum of two different supply rails. The device operates from the lower supply until output headroom becomes an issue. At this point the device switches the output stage to the higher supply rail. Once the output signal drops below a pre-determined level, the device switches back to the lower rail. Power dissipation is greatly reduced for typical musical or voice sources. *Figure 3* illustrates a simplified Class G implementation with a split supply Class AB output stage.

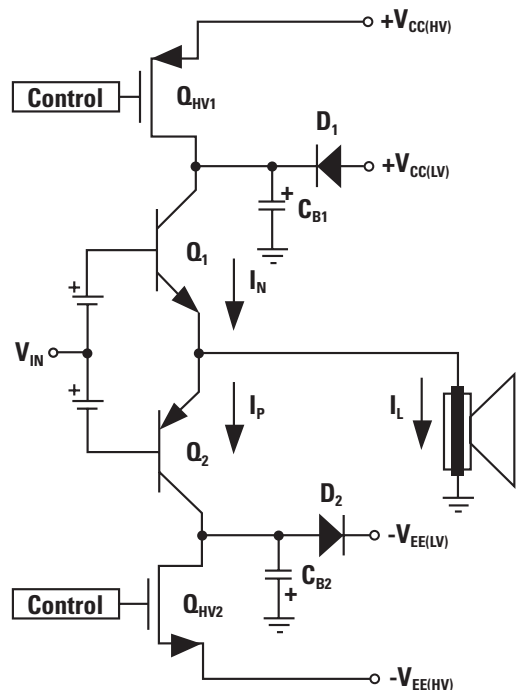

**Figure 3. Basic Class G Design Using Split-Supply Class AB Output Stage**

## PowerWise® Class G versus Class AB Headphone Amplifiers

A MOSFET is used as a switch to change the supply rails from the lower voltage (LV) to the higher supply voltage (HV) for the output stage.

There are several ways to control the switching of the supply rails. Feedback from the output stage may be used and/or the input and pre-amp stage may have the control. The control could have some time constant so that when a switch to the higher rails occurs, there is some delay before the FETs turn back off and the output stage shifts back to the lower supply rails. The speed of the change also will need to be controlled appropriately for minimal loss of power in the FETs.

*Figure 4* shows an example of a music output signal. The dotted lines are the supply voltages for the output stage. When the output signal requires a higher supply voltage, the FETs are turned on and the supply voltage increases to the higher rail. Once the output signal falls below the internally-set threshold, and after some delay, the device switches back down to the lower rail, reducing power dissipation.

Designers must balance many trade-offs associated with Class G: selecting the proper number of supplies and the voltage difference between the supplies in order to optimize headroom at lower voltages, while minimizing power dissipation. Two different rails minimize the complexity of the power supplies, while providing sufficient voltage flexibility. Additional rails may reduce power dissipation further but at the cost of higher component count, complexity, and reliability. Another issue is the length of time the device operates from the higher rail. While operating from the higher supply rail, power dissipation increases. Switching back to the lower rail too early may result in distortion due to clipping, while remaining at the higher rail for an extended period of time will result in a degradation of efficiency.

An example of a Class G device is National Semiconductor's LM48824 Class G headphone amplifier. The LM48824 amplifier operates from two voltage supplies (1.1V and 1.8V) generated by an integrated

step-down (buck) regulator. When the audio output exceeds an internally-set threshold, buck converter output increases from 1.1V to 1.8V. When the audio signal falls below the required voltage rails for a set period of time, the buck converter output decreases back to 1.1V. Power dissipation is greatly reduced for typical musical or voice sources. *Figure 4* shows how a musical output may look. The green line corresponding to  $HPV_{DD(HV)}$  and  $HPV_{DD(LV)}$  is the buck converter output. The green line corresponding to  $HPV_{SS(HV)}$  and  $HPV_{SS(LV)}$  is the inverting charge pump output.

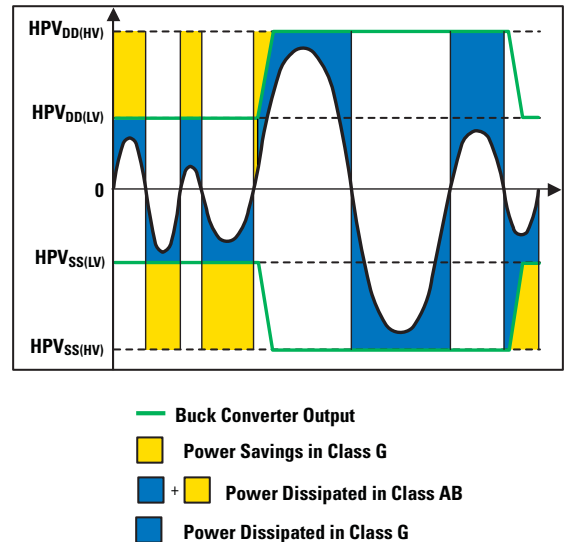

**Figure 4. Music Output Example**

### Class G Efficiency

Class G efficiency depends largely on the source material (music or voice) and the characteristics of the signal. With pure sine waves, depending on signal amplitude, there is no efficiency gain compared to a Class A, B, or AB amplifiers under the same conditions. If the amplitude remains at a level where the Class G device operates from its lower supply rail, then power dissipation does decrease compared to the other architectures that can only operate from a fixed, higher voltage supply.

For real-world Class G amplifiers, the maximum efficiency occurs when operating under the lowest supply rails as opposed to operating at peak output power on the higher rails due to biasing conditions, current x voltage ( $I \times V$ ) loss, and IR losses in the FETs. Peak efficiency depends on the supply voltage switchover threshold. A design that switches at a lower level improves efficiency when operating from the lower supply but causes the device to operate from the higher supply for a longer period. Ideally, a Class G device operates for as long as possible from the lower supply, minimizing  $I \times V$  losses incurred when operating at higher voltages. The power considerations must be balanced with maintaining proper headroom, so distortion due to clipping does not become an issue.

## **National Class G Technology**

The LM48824 headphone amplifier integrates a high-efficiency step-down (buck) DC-DC switching regulator with a ground-referenced headphone amplifier. The switching regulator delivers a constant voltage from an input voltage ranging from 2.4V to 5.5V. The switching regulator uses a voltage-mode architecture with synchronous rectification, improving efficiency and reducing component count. The LM48824 amplifier features National's ground-referenced architecture that eliminates the large DC-blocking capacitors required at the outputs of traditional single-ended headphone amplifiers. A low-noise inverting charge pump creates a

negative supply (HPVSS) from the positive supply voltage ( $V_{DD}$ ). The headphone amplifiers operate from these bipolar supplies, with the amplifier outputs biased about GND. Because there is no DC component on the output signals, the large DC-blocking, AC-coupling capacitors (typically 220  $\mu\text{F}$ ) are not necessary, thereby conserving board space, reducing system cost, and improving frequency response.

The LM48824 amplifier takes advantage of National's proprietary headphone architecture that incorporates Class G amplifiers offering power savings compared to traditional Class AB headphone amplifiers. Additionally, output noise is improved by common-mode sensing that corrects for any differences between the amplifier ground and the potential at the headphone return terminal, minimizing noise created by any ground mismatches. A high-output impedance mode allows the LM48824 amplifier's outputs to be driven by an external source without degrading the signal. Other features include flexible power supply requirements, differential inputs for improved noise rejection, a low-power (2.5  $\mu\text{A}$ ) shutdown mode, and a 32-step I<sup>2</sup>C-compatible volume control with mute function. The LM48824 amplifier's click-and-pop suppression eliminates audible transients on powerup/down and during shutdown. The LM48824 amplifier is available in an ultra-small 16-bump, 0.4 mm pitch micro SMD package (1.7 x 1.7 mm).

# Design Tools

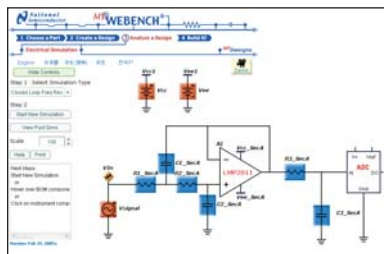

## WEBENCH® Signal Path Designer® Tools

Design, simulate, and optimize amplifier circuits in this FREE online design and prototyping environment allowing you to:

- Synthesize an anti-alias filter
- Select the best amplifier/ADC combo for your system specs
- Make trade-offs based on SNR, SFDR, supply voltage
- Simulate real-world operating conditions using SPICE
- Receive samples in 24 hours

[national.com/webench](http://national.com/webench)

## WaveVision 4.1 Evaluation Board

Test and evaluate A/D converters with National's easy-to use WaveVision 4.1 evaluation board. Each evaluation board comes complete with USB cable and support software.

### Features and benefits:

- Plug-n-play ADC evaluation board
- USB 2.0 interface to PC
- PC-based data capture
- Easy data capture and evaluation
- Highlighted harmonic and SFDR frequencies
- Easy waveform examination
- Produces and displays FFT plots
- Dynamic performance parameter readout with FFT
- Produces and displays histograms



**National Semiconductor**  
2900 Semiconductor Drive  
Santa Clara, CA 95051  
1 800 272 9959

**Mailing address:**  
PO Box 58090  
Santa Clara, CA 95052

**Visit our website at:**  
[www.national.com](http://www.national.com)

**For more information,  
send email to:**  
[new.feedback@nsc.com](mailto:new.feedback@nsc.com)

## Don't miss a single issue!



Subscribe now to receive email alerts when new issues of Signal Path Designer® are available: [national.com/spdesigner](http://national.com/spdesigner)

Also, be sure to check out our Power Designer! View online today at: [national.com/powerdesigner](http://national.com/powerdesigner)

