



PowerWise® Adaptive Voltage Scaling (AVS) for Gaming Applications

Adaptive Voltage Scaling (AVS)

Adaptive Voltage Scaling (AVS) technology is a real-time, continuous, closed-loop power management technology. The AVS technology enables optimized power delivery to processors, ASICs, and SoCs by adaptively optimizing supply voltages over process and temperature variations in order to maximize system-level energy savings.

Gaming Applications

Gaming consoles are rated primarily on their performance capability. Consumers are increasingly demanding for enhanced in graphics and game play. However, there are several practical constraints that come with designing a gaming console.

Although they pack the processing power of a modern PC, game consoles must compare favorably in size with existing gaming platforms. This poses a difficult thermal management problem for the console as higher end consoles can consume 150 to 200 Watts in normal operation. Getting the heat out of these systems often requires expensive heat sinks and heat pipes, which themselves take up significant space.

Since consoles are used for a variety of audio and visual entertainment; excessive fan noise detracts from the experience. Larger fans are required to remove the increasing heat due to increase power consumption. It is not uncommon for fan noise reduction to be the goal of a redesign.

What AVS Can Do

AVS addresses the tradeoff between power and performance. The V_{DD} of the core must be high enough to support ever increasing clock rates. However, the higher V_{DD} , the more power that is dissipated by the processor. In fact, the power consumption is proportional to V_{DD}^2 , and even greater than this when considering leakage. This power dissipation in turn requires larger and more expensive heat sinking solutions. Even with the modern practice of voltage binning, considerable voltage headroom due to tester guardbands, temperature variation, and other inaccuracies. AVS eliminates these guardbands, and delivers exactly the voltage needed for a given performance through a closed-loop determination of the optimally lowest voltage. The result is power savings in the range of 20 – 40%. Power savings have a domino effect in gaming consoles. For every watt saved in the processor, there are savings in the heat sink, size, and cost.

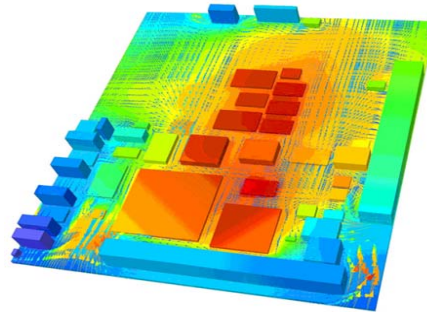

AVS Implementation in Gaming

The HPM (Hardware Performance Monitor) and APC (Advance Power Controller) are embedded into the processor in order to monitor the process and temperature variation of the ASIC. A command is sent by APC via the PowerWise Interface (PWI) to the Energy Management Unit (EMU), which adaptively regulates with a load-line offset. Together, these components form a closed loop which automatically optimizes the voltage for the given process and temperature profile. The AVS loop is fast enough to accommodate frequency scaling, which provides even more power savings.

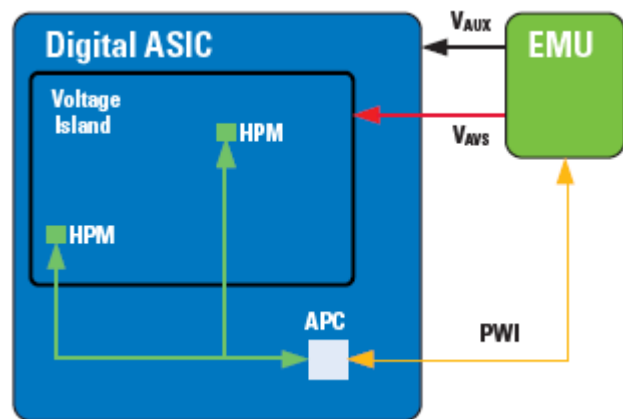

AVS Power Savings

AVS enables 20% to 40% power savings over traditional fixed-voltage scheme across temperature range and guardbands typical in high performance processors.

Applications

- Gaming Consoles
- High-end Set Top Boxes