



PowerWise® Adaptive Voltage Scaling (AVS) for Converged Network Adapter (CNA) Cards

Adaptive Voltage Scaling (AVS)

Adaptive Voltage Scaling (AVS) technology is a real-time, continuous, closed-loop power management technology. AVS technology enables optimized power delivery to processors, ASICs, and SoCs by adaptively optimizing supply voltages over process and temperature variations maximizing system-level energy savings.

Converged Networks

Modern data centers face significant challenges of balancing escalating computation needs with power and cooling constraints. The wide adoption of virtualization in blade servers enabled consolidation for computation tasks. To reach the next level of energy efficiency and cost effectiveness IT managers are moving towards a unified data center fabric based on Enhanced Ethernet and Fiber Channel over Ethernet (FCoE). Combining LAN and SAN hardware simplifies network interconnect.

Converged Network Adapter (CNA) is an effective way to consolidate server I/O ports. In addition to providing a common connection to the physical media, the CNA can process network traffic, increasing CPU utilization allocated for virtual machines on a server. Protocol offloading is a digital intensive process which generally consumes significant amount of power. Energy efficiency can be significantly enhanced with AVS technology.

AVS Implementation in CNA

CNAs come in standard PCI Express add-in card form factors. Power is provided (3.3V and 12V) by the host through dedicated connector pins, and is converted by on-board regulators to useful ASIC voltages. AVS is effective in minimizing power consumption of digital circuits.

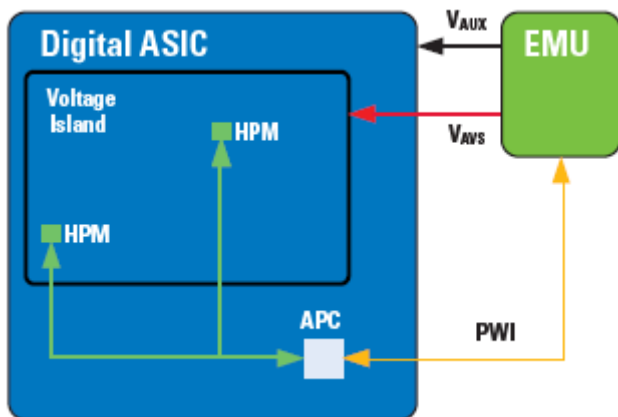

To realize the benefits of AVS, the HPM (Hardware Performance Monitor) and APC (Advance Power Controller) are embedded into the CNA ASIC to monitor the process and temperature variation of the ASIC.

The voltage optimization command is sent by the APC via the PowerWise Interface (PWI) to the Energy Management Unit (EMU) forming a closed loop that continually optimizes the supply voltage based on system conditions. AVS runs in parallel with the core ASIC, adding no additional overhead to internal critical paths.

AVS Power Savings

Table 1 illustrates representative AVS benefits for a generic CNA system. Note that AVS does not reduce the power to the small form-factor pluggable (SFP+) module, or the high-speed SERDES circuits. The power consumption of the digital circuits will be reduced, by 35% on average, for fixed frequency operation, translating to a system level power reduction of over 20%.

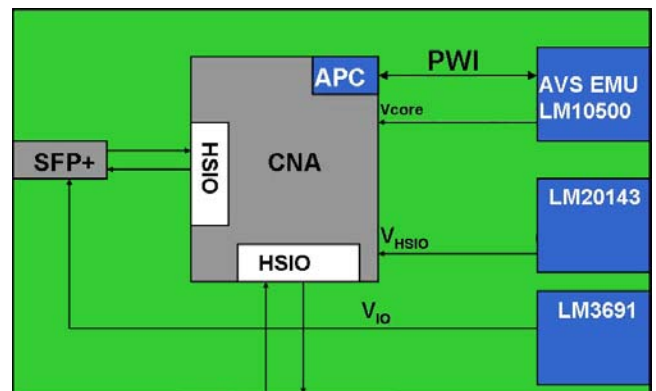

Supply Domain	Standard System			AVS Enabled System		
	Voltage	Current	Power	Voltage	Current	Power
SFP+	3.3V	0.5A	1.7W	3.3V	0.5A	1.7W
High Speed I/O	1.1V	1.6A	1.8W	1.1V	1.6A	1.8W
Core Logic	1.1V	6A	6.6W	0.9V	5A	4.4W
	Total Power: 10W			Total Power: 7.8W		

Table 1: Typical AVS Power Savings

Applications

- Fiber Channel over Ethernet (FCoE)
- Enhanced Ethernet
- Unified Fabrics