

No. 126

Feature Article 1-6

TRIAC Dimmable
LED Driver 2

Dimming Techniques for Switched-Mode LED Drivers

— By Rich Rosen, Field Applications Engineer

Introduction

The exponential growth of LED lighting has ushered in a vast selection of integrated circuit devices to provide controlled power to LEDs. No longer acceptable to an energy-conscious world, switched-mode LED drivers have long since replaced power-hungry linear current sources as the standard. Applications from flashlights to stadium scoreboards all require precise control of regulated currents. In many instances, real-time changes in LED output intensity are required. This function is commonly referred to as dimming control. This article describes some basic LED theory and several techniques used to provide dimming control to switched-mode LED drivers.

LED Brightness and Color Temperature

LED Brightness

The concept of the brightness of visible light from an LED is fairly easy to understand. Assigning a numerical value to the perceived brightness of an LED's output can simply be measured in units of luminous flux density, called candelas (cd). The total power output of an LED is a measurement of the amount of Lumens (lm).

It is also important to understand that average forward LED current determines the brightness of an LED.

Figure 1 shows the relationship between forward LED current vs. Lumens output for a certain LED. The relationship is remarkably linear over useable ranges of I_F or forward current. Note the nonlinearity appearing as I_F increases. Reduced efficacy in Lumens per Watt arises as the operating current exceeds the linear range.

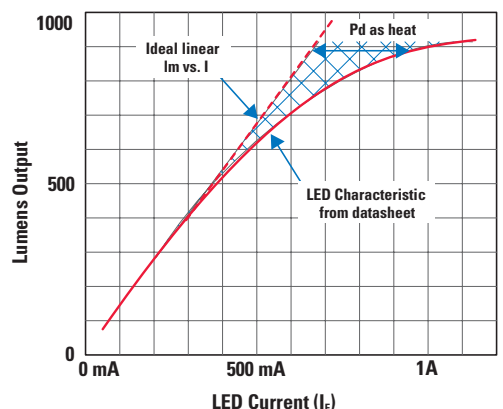

Figure 1. LED Output vs. LED Current



Best-in-Class Dimming Performance. High Efficiency.

High Performance, TRIAC Dimmable LED Driver

National's industry-leading TRIAC dimmable offline LED driver solution is perfect for any application where an LED driver must interface to a standard TRIAC wall dimmer. National's new TRIAC dimmable LED driver delivers a wide, uniform dimming range free of flicker, best-in-class dimming performance, and high efficiency—all while maintaining ENERGY STAR® power factor requirements in a typical application.

- ✓ *Online design tools*
- ✓ *Reference designs*
- ✓ *Application notes*



Full Range Dimming Capability

National's TRIAC dimmable LED driver offers 100:1 full range dimming capability, going from full light to nearly imperceptible light in a continuous range without being extinguished, and maintains a constant current to large strings of LEDs driven in series off of a standard line voltage.

Easy To Use

National's TRIAC dimmable LED driver enables a direct replacement of incandescent or halogen lamp systems that are currently interfaced to a TRIAC dimmer without having to change the original infrastructure or sacrifice performance. In addition, the new TRIAC dimmable LED driver is available in WEBENCH® LED Designer to allow for easy and quick design in.

Uniform Dimming Without Flicker

National's TRIAC dimmable LED driver allows master-slave operation control in multi-chip solutions which enables a single TRIAC dimmer to control multiple strings of LEDs with smooth consistent dimming, free of flicker.

Dimming Techniques for Switched-Mode LED Drivers

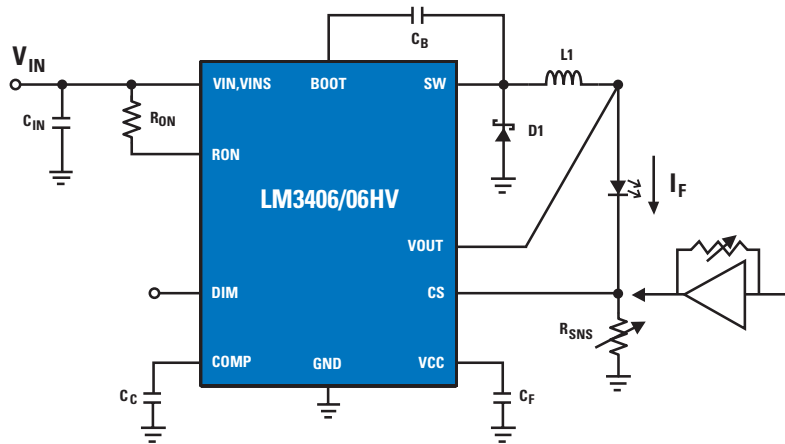

Figure 2. Buck Regulator Topology

Operation above the linear range results in output power converted to heat from the LED. This wasted heat burdens the LED driver and increases the complexity of the thermal design.

LED Color Temperature

Color temperature is a metric that describes the color of the LED and is quantified in LED datasheets. The color temperature of a given LED will be specified within a range and will shift with variances in forward current, junction temperature, and age. Lower color temperatures are more red-yellow (called warm) and higher-valued color temperatures are more blue-green (called cooler). Many colored LEDs will specify dominant wavelength instead of color temperature and are also subject to shift in wavelength.

LED Dimming Methods

Two popular methods for dimming LEDs in switched-mode driver circuits exist: Pulse-Width Modulation (PWM) dimming and analog dimming. Both methods control the time-averaged current through the LED or LED string, but there are differences between the two which become evident when examining the advantages and disadvantages of the two types of dimming circuits.

Figure 2 shows a switched-mode LED driver in a buck topology. V_{IN} must always be higher than the voltage across the LED + R_{SNS} . The inductor current is the LED current. The current is regulated by monitoring the voltage at the current sense or CS pin. As current sense or CS starts to fall below a set voltage, the duty cycle of the current pulses going through L1, the LED and R_{SNS} increase; which increases the average LED current.

Analog Dimming

Analog dimming of LEDs is the adjustment of cycle-by-cycle LED current. More simply put, it is the adjustment of the constant LED current level. Analog dimming can be accomplished by an adjustment of the current sense resistor R_{SNS} , or by driving an analog voltage on some DIM function pin of the IC. Figure 2 shows two examples of analog dimming.

Analog Dimming by Adjustment of R_{SNS}

It is clear from Figure 2 that a change in value of R_{SNS} will correspond to a change in LED current with a fixed CS reference voltage. If one could find a potentiometer that could handle the high LED current and also was available in sub-1 Ohm values, this would be a viable method to dim the LED.

Dimming Techniques for Switched-Mode LED Drivers

Analog Dimming by Driving DC Voltage on the CS Pin

More complex is a technique to directly control the cycle-by-cycle current of the LED by means of driving a voltage into the CS pin. The voltage source is typically inserted into a feedback loop where LED current is sampled and buffered by the amplifier (*Figure 2*). The LED current can be controlled by the gain of the amplifier. With this feedback circuitry, functionality such as current and thermal foldback can be implemented for further LED protection.

A disadvantage to analog dimming is that the color temperature of the emitted light can vary as a function of LED current. In situations where the color of the LEDs is critical, or the particular LED exhibits a large change in color temperature with changes in LED current, dimming the output of the LED by changing the LED current would be prohibitive.

PWM Dimming

The PWM method of dimming is the actual start and restart of the LED current for short periods of time. The frequency of this start-restart cycle must be faster than the human eye can detect to avoid a flickering effect, about 200 Hz or faster is usually acceptable.

The dimming of the LED now becomes proportional to the duty cycle of the dimming waveform, governed by the formula:

$$I_{DIM-LED} = D_{DIM} \times I_{LED}$$

where $I_{DIM-LED}$ is the average LED current, D_{DIM} is the duty cycle of the dim waveform, and I_{LED} is the nominal LED current setup with the selection of R_{SNS} as shown in *Figure 3*.

Modulating the LED Driver

Many modern LED drivers feature a specialized PWM DIM pin that accepts a wide range of PWM frequencies and amplitudes, allowing a simple interface to external logic. The DIM function only shuts down the output drive while leaving the internal circuitry operating, avoiding the delay of restarting the IC. Output Enable pins and other logic shutdown functions can be used.

Two-Wire PWM Dimming

Two-wire PWM dimming is a popular method for automotive interior lighting. As V_{IN} is modulated below 70% of $V_{IN-NOMINAL}$, the VINS pin (*Figure 3*) detects the change in voltage and converts the PWM waveform into a corresponding PWM of the output drive. The disadvantage to this method is the power source to the converter must contain a circuit to provide a PWM waveform to its DC output.

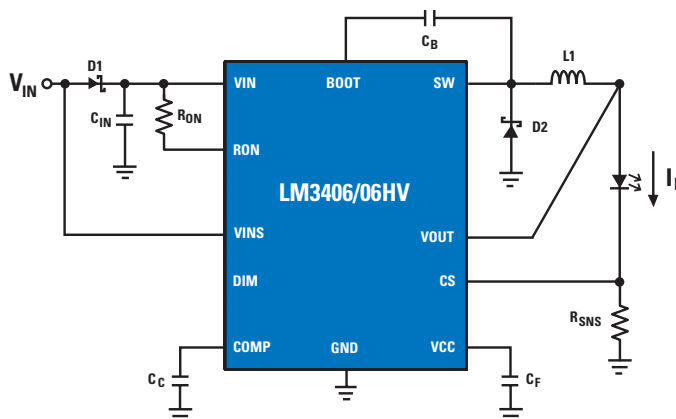

Figure 3. Two-Wire PWM Dimming

Dimming Techniques for Switched-Mode LED Drivers

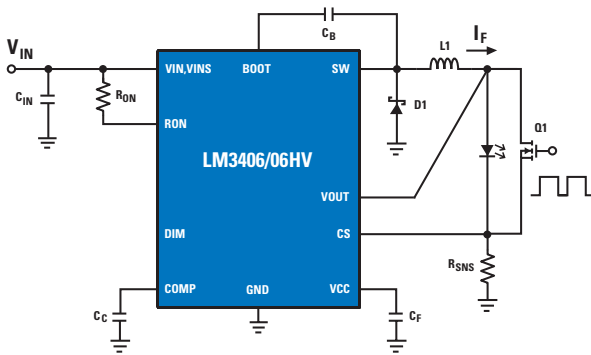

Figure 4. Fast PWM Dimming

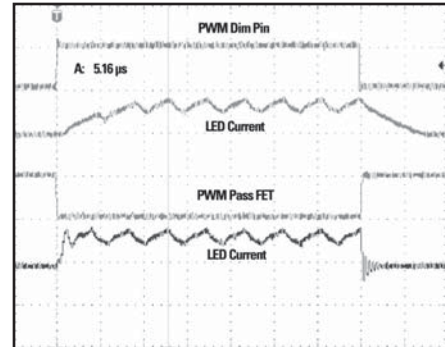

Figure 4. Circuit and PWM Waveforms

Fast PWM Dimming with a Shunt Device

Because of the delays in shutdown and start up of the converter's output, there is a limit to the PWM dimming frequency and range of duty cycles. To help overcome this delay, an external shunt device such as the FET shown in *Figure 4* can be placed parallel to the LED or LED string to quickly bypass the converter's output current around the LED(s).

The current in the inductor stays continuous during the "LED shutdown time," avoiding the long delay in ramping up and down the inductor current pedestal. The delay time now shifts to the limits of the shunt device's rise and fall times. *Figure 4* shows the LM3406 fitted with a shunt FET and a plot comparing the LED on/off delays between using the DIM function pin vs. the shunt FET. The output capacitance used in both of these measurements is 10 nF and the shunt FET is a Si3458.

Caution should be used with shunting the LED current with current-mode converters because of the overshoot in output current when the FET turns on. The LM340x family of LED drivers are controlled on-time converters and will not exhibit this overshoot. Output capacitance across the LEDs should be kept low to maximize on/off/on transition speed.

A disadvantage to the fast-dim circuit vs. shutting-down the outputs is loss of efficiency. While the shunt device is on, a power dissipation of $V_{SHUNT\ DEVICE} \times I_{LED}$ is lost as heat. Use of low R_{DS-ON} FETs will minimize this loss of efficiency.

LM3409 Multiple Dimming Functions

National Semiconductor's LM3409 is a unique LED driver in that it provides functionality for easy analog and PWM dimming. There are four possible ways to implement LED dimming on this part:

1. Analog dim by directly driving the I_{ADJ} pin with a voltage source from 0V to 1.24V
2. Analog dim by placing a potentiometer between I_{ADJ} pin and GND
3. PWM dim with the Enable pin
4. PWM dim by external shunt FETs

The LM3409 is wired for analog dimming by use of a potentiometer (*Figure 5*). Internal 5 μ A current source creates a voltage across R_{ADJ} , which in-turn varies the internal current sense threshold. The I_{ADJ} pin can be directly driven with a DC voltage for the same effect.

Dimming Techniques for Switched-Mode LED Drivers

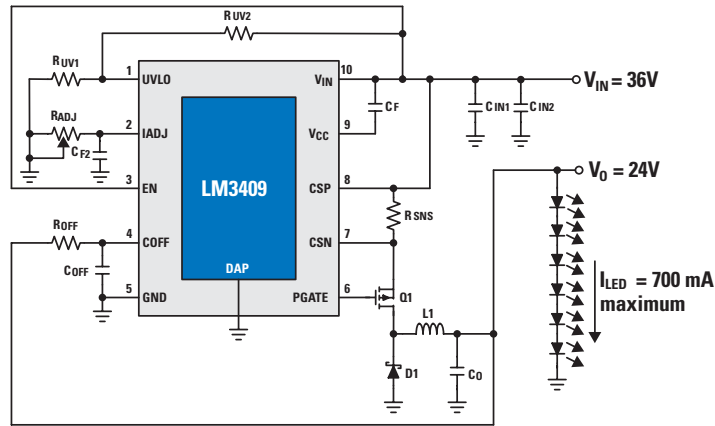

Figure 5. Analog Dimming Application

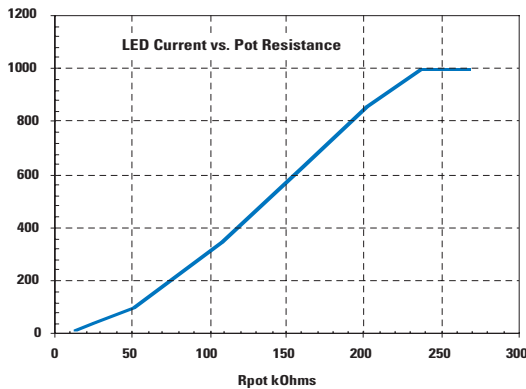

Figure 6. LED Current vs. Pot Resistance

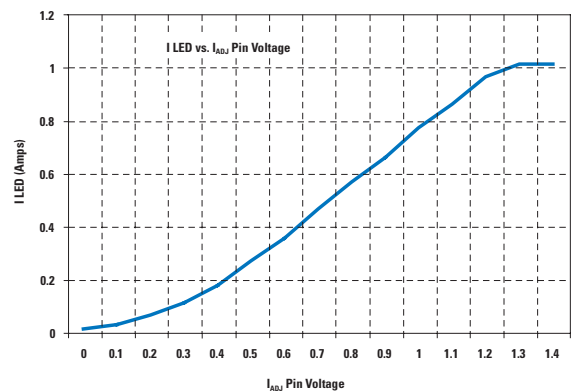

Figure 7. LED vs. I_{ADJ} Pin Voltage

Figure 6 shows a plot of measured LED current vs. the potentiometer resistance between the I_{ADJ} pin to GND. The flat-top at 1 Amp represents the maximum nominal LED current, set by the current sense resistor R_{SNS} shown in Figure 4.

Figure 7 shows the measured LED current as a function of driven DC voltage onto the I_{ADJ} pin. Notice the same maximum LED current set by R_{SNS}.

Both analog dimming options are easy to implement and provide very linear dim levels down to around 10% of maximum.

Summary

There are many approaches to dimming LEDs powered by switched-mode regulators. The two main categories, PWM and analog, both have advantages and disadvantages. PWM dimming greatly reduces color changes in the LED with varying brightness levels at the expense of additional logic to create the PWM waveforms. Analog dimming can be a more simplistic circuit, but may be inappropriate for applications that require a constant color temperature.

Power Design Tools

Tools for Energy-Efficient Designs

Access white papers, reference designs, and application notes on PowerWise® products and systems.

national.com/powerwise

Technology Edge App Notes

National's monthly analog design technical journal.

national.com/edge

TECHNOLOGY
Edge 

Online Seminars

Free online seminars by industry experts. Log onto National's analog online seminars today.

national.com/online seminars

ONLINE
Seminars 

National Semiconductor
2900 Semiconductor Drive
Santa Clara, CA 95051
1 800 272 9959

Mailing address:
PO Box 58090
Santa Clara, CA 95052

Visit our website at:
national.com

**For more information,
send email to:**
new.feedback@nsc.com

 **National**
Semiconductor

Don't miss a single issue!



Subscribe now to receive email alerts when new issues of Power Designer are available:

national.com/powerdesigner

Read our Signal Path Designer® online today at:

national.com/spdesigner

