

TECHNOLOGY | edgeSM

Small, Wide Input Voltage Range LM2842 Keeps LEDs Cool

Application Note AN-1982

Clinton Jensen, Senior Applications Engineer

Introduction

The world seems to be poised to make the leap to LED lighting. Incandescent has been deemed too inefficient, which it is, and fluorescent lighting often does not achieve the lifetime it claims. Fluorescent also has another set of baggage, dangerous chemicals. So the logical choice that most people believe can take the crown is HB (high brightness) LEDs. HBLEDs are becoming more attractive as the manufacturers of such devices are making great strides in increasing the lumens per watt that they can produce which improves the efficiency. It will not be long before LEDs produce significantly more lumens per watt than current fluorescent lamps.

Two of the main initial areas of focus for replacement with LED lighting are low voltage down lighting and track lighting. These would include replacements for standard sizes such as MR16, PAR20, PAR25, PAR30, and PAR38. National already offers a variety of solutions for driving multiple LEDs beautifully for such applications including the LM342x and LM340x series of LED drivers. But regardless of how the LEDs are driven they have one issue: They produce heat. In these small enclosures a heatsink with free flowing air is often not enough. This forces the designer of the fixture into a situation where some forced air is required. The most practical solutions for a fixture of such size are either a DC fan or a more elegant and rugged solution provided by the Nuventix, Inc. Synjet®. A fan is generally a more cost effective solution and can run off either 5VDC or 12VDC rail but it can be difficult to fit into these enclosures and has a lifetime measuring in the tens of thousands of hours at best. On the other hand the Synjet is designed specifically to fit into each of these enclosures, runs off of 5VDC, and has a lifespan on the order of 100k hours.

The standard inputs for these systems can be either a DC system or an AC system. 12VAC and 24VAC systems have been common for some time for low voltage lighting, but 12VDC and 24VDC systems are making a push and are becoming more common. Since there are many 12V systems it makes for an easier design to drive a 5V cooling mechanism. But since there are multiple systems that could provide a very wide input voltage range, particularly in the case of the AC inputs, it would be nice to have one solution that could take the wide input range and provide the 5V rail while taking up very little space and could easily fit into such enclosures. Fortunately the LM2842 does this quite nicely as does the LM2841 for the smaller fixtures.

The DC input systems offer the easiest and most simple solution as a regulator with a wide input voltage range can take this voltage directly and convert it to a 5V rail. Typical solutions including both the fan and the Synjet require between 100 mA and 600 mA to power them. The LM2841 can supply up to 300 mA for the smaller cooling systems while the LM2842 can supply up to 600 mA for the larger, more powerful cooling systems. *Figure 1* shows the LM2842 designed to take either a 12VDC or 24VDC input and provide the 5V rail necessary. The entire solution for driving up to 600 mA only takes about 1/4 square inch of PCB real estate making it easy to fit into any of the retrofit fixtures. The LM2841 would be an identical design for the lower current applications but would allow for a physically smaller inductor and would take up less space.

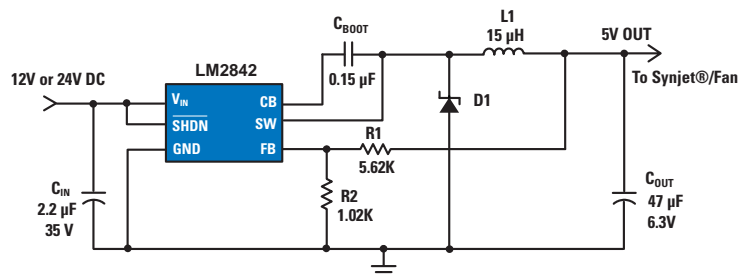

Figure 1: DC Input 5VDC Output

However, as mentioned, many 12VAC and 24VAC systems are still in place throughout the world and it is most often desirable to be able to retrofit and use these systems rather than replacing them with a more modern DC system. This means that a design with a wide input voltage range must be used. This can be done rather simply by using a bridge rectifier and a larger amount of input capacitance to form a crude AC-DC converter. Given line tolerances, a 24VAC system could provide peaks nearing 40V. But you would also like to be able to minimize the input capacitance which would allow the input to fall as low as 10V to 12V. The LM2841 and LM2842 can accommodate such a wide input voltage range with sufficient power supply rejection to keep the output perfectly steady at 5V. *Figure 2* and *Figure 3* show the circuits for a 12VAC system and a 24VAC system respectively.

It is important to note, the 24VAC input has a higher RMS voltage and therefore the

LM2842 draws less current. It also has a higher peak. Due to these facts a lower value input capacitor can be used to maintain an acceptable operating input voltage to the LM2842. Also important to note is that the circuits in *Figure 2* and *Figure 3* are designed for the full output current of 600 mA. It becomes apparent that if the cooling system uses less current, then less input capacitance could be used further reducing the circuit size. For example, if the LM2842 were to be substituted with the LM2841 running a maximum of 300 mA of output current then the input capacitance could be cut in half.

This article does not focus on the LED drive circuitry itself since that is a subject for another article. But it does show that thermal management of the LEDs does not have to be a difficult issue if you have the right drive tools available. Visit national.com/LED for more information on National's LED drivers and to use WEBENCH® LED Designer.

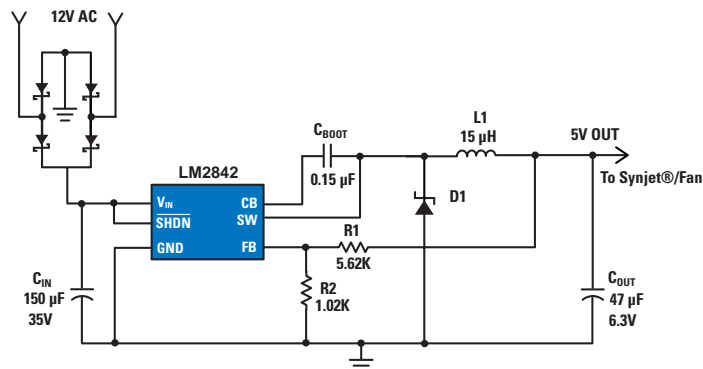

Figure 2: 12VAC Input to 5VDC Output

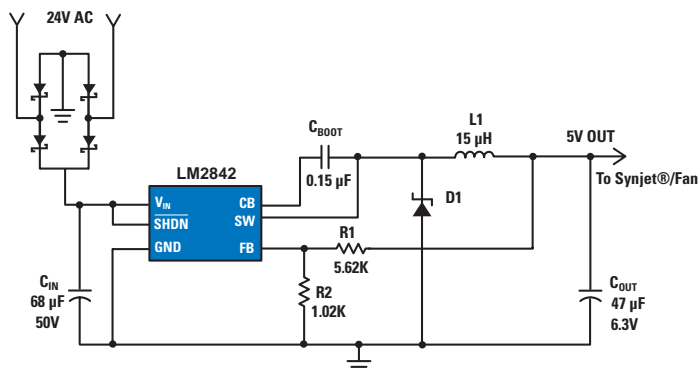

Figure 3: 24VAC Input to 5VDC Output

National Semiconductor
2900 Semiconductor Drive
Santa Clara, CA 95051
1 800 272 9959

Mailing Address:
PO Box 58090
Santa Clara, CA 95052

For Additional Design Information

national.com/edge

