

No. 104

Feature Article1-7

Telecommunications
Solution2

Industrial Diagnostics and
Factory Automation....4-5

Design Tools8

Machinery Monitoring

— By Walter Bacharowski, Applications Engineer

Machinery downtime during normal shift operations is very costly due to lost production, but it is also avoidable. Preventative maintenance systems are being used to improve the operating efficiency of machinery used in factories, power plants, mining, and many other operations.

Diagnostic electronics, used in newer preventative maintenance programs, monitor the operating parameters of the machine. For example, a roller mill may have several large electric motors and rollers, all of which have bearings, a hydraulic pump, and a variety of hydraulic actuators. A preventative maintenance system for this type of equipment could include electronic monitoring equipment to measure bearing vibration and temperature, hydraulic fluid pressure and temperature, and motor temperature.

Vibration analysis, which is the measurement of vibrations generated by moving parts in the frequency range of 50 Hz to 10 kHz, can be used to monitor the condition of bearings and other moving components. Ultrasonic analysis, an extension of vibration analysis, uses higher frequencies in the 15 kHz to 40 kHz range. Changes are detected through spectral analysis of the generated frequencies in the moving components due to wear or damage. As parts wear, the magnitude of the vibrations and ultrasonic noise will increase. An increase of about 12 dB indicates possible impending failure.

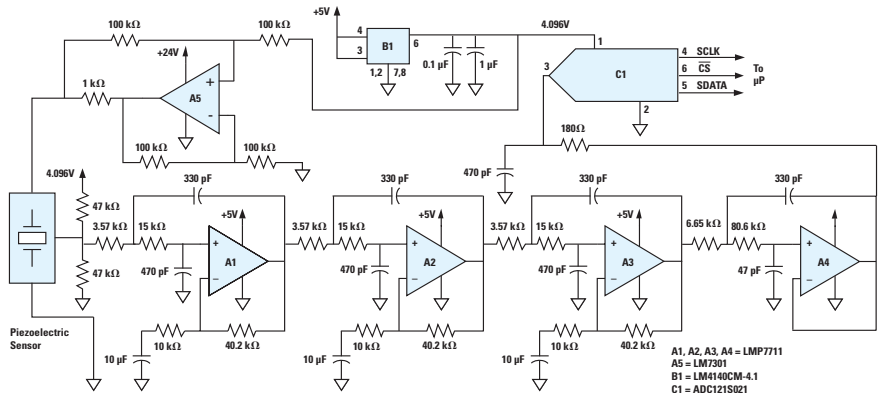

Figure 1. Vibration Analysis Signal Chain

NEXT ISSUE:

Lidar/Radar Design

Signal-Path Solutions for Telecommunications

GPS Application

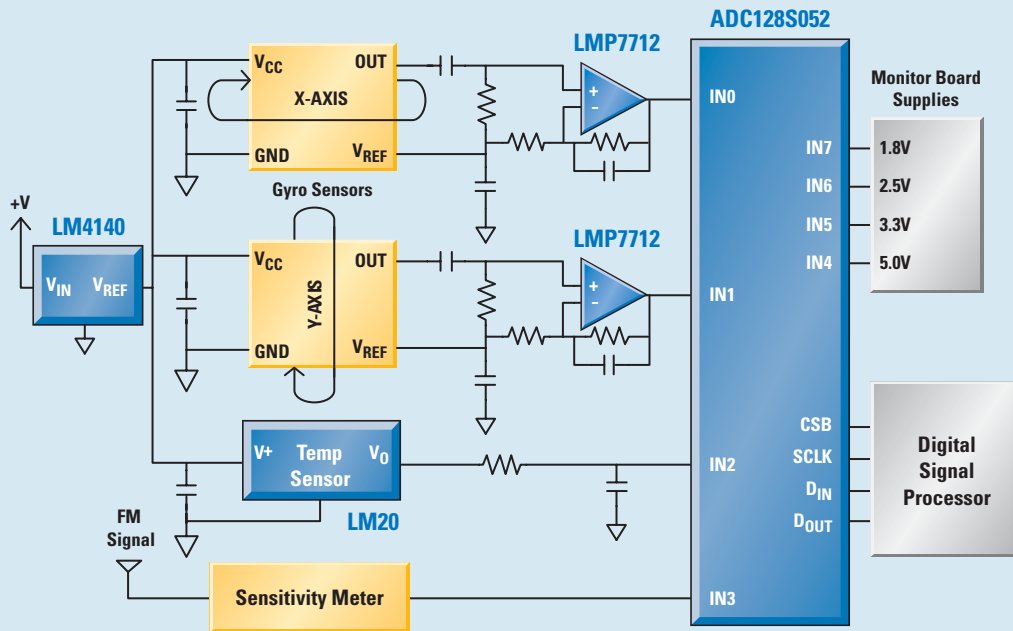

Precision Amplifiers

Product ID	Key Features	Typ Supply Current (mA)	Supply Voltage Range (V)	Max Input Offset Voltage (mV)	Unity Gain Bandwidth (MHz)	Low Input Current CMOS Design	Temp Range (°C)
LMP7712	Precision, low-noise RRO dual CMOS	1.15	1.8 to 5.5	0.15	17	✓	-40 to +125
LMP7702	Precision, 12V RRIO dual CMOS	0.73	2.7 to 12	0.2	2.5	✓	-40 to +125
LMP2012	90% power saving RRO performance amp	1.2	2.7 to 5.25	0.025	3	—	-40 to +125

Serial Peripheral Interface (SPI) ADCs for 8-Channel Applications

Product ID	Res	# of Inputs	Pin/Function Compatible	Throughput Rate (kSPS)	Input Type	Max Power 5V/3V (mW)	Supply (V)	Max INL (LBS)	Min SINAD (dB)	Packaging
ADC78H90	12	8	↑ ↓	500	Single ended	12/8.3	2.7 to 5.25	±1.0	70	TSSOP-16
ADC128S102	12	8		500 to 1000	Single ended	15.5/4.5	2.7 to 5.25	±1.2	70	TSSOP-16
ADC128S052	12	8		200 to 500	Single ended	13/3.6	2.7 to 5.25	±1.0	70	TSSOP-16
ADC128S022	12	8		50 to 200	Single ended	11.5/3.3	2.7 to 5.25	±1.0	70	TSSOP-16
ADC108S102	10	8		500 to 1000	Single ended	13.6/4.2	2.7 to 5.25	±0.5	61.3	TSSOP-16
ADC108S052	10	8		200 to 500	Single ended	12.1/3.3	2.7 to 5.25	±0.4	61.3	TSSOP-16
ADC108S022	10	8		50 to 200	Single ended	10.5/2.8	2.7 to 5.25	±0.3	61.3	TSSOP-16
ADC088S102	8	8		500 to 1000	Single ended	11/3.6	2.7 to 5.25	±0.2	49.2	TSSOP-16
ADC088S052	8	8		200 to 500	Single ended	8.5/3	2.7 to 5.25	±0.2	49.2	TSSOP-16
ADC088S022	8	8		50 to 200	Single ended	7.8/2.2	2.7 to 5.25	±0.2	49.2	TSSOP-16

Machinery Monitoring

This type of monitoring allows repairs to be made before the component fails. In many cases, vibration analysis and ultrasonic analysis require two different pieces of equipment. A single, cost-effective instrument that can monitor the complete frequency range would be useful. A schematic diagram of a vibration and ultrasonic analysis signal chain is shown in *Figure 1*.

The piezoelectric sensor senses the vibrations and ultrasonic noise generated by the bearings. The piezoelectric element is buffered internally by a MOSFET, which is driven by a constant current source, amplifier A5, and is internally AC coupled to the filter. Amplifiers A1, A2, and A3 implement a gain of 41.9 dB in conjunction with a 6-pole low-pass filter. Amplifier A4 has a gain of 1 with a 2-pole filter. The ADC121S021 Analog-to-Digital Converter (ADC), which operates at a 200 kHz sampling rate, digitizes the amplified and filtered signal. The microprocessor's software performs a FFT (Fast Fourier Transform) on the data to obtain the frequency and magnitude information. The pass band of the circuitry shown is about 40 kHz. A typical wide band vibration sensor has a transfer function in the form of *Figure 2*.



Figure 2. Sensor Transfer Function

The low frequency will start to roll off around 30 Hz and will be relatively flat until a resonance frequency occurs at 65 kHz, after which the response falls rapidly. The peak-to-peak amplitude in the flat band is about 32 mV_{P-P} and will be amplified to 4 V_{P-P}. The gain will be:

$$\frac{4.096 \text{ V}}{0.032} = 128$$

A gain of 125 will be used to provide some margin.

In relation to the maximum signal frequency of interest, 40 kHz in this case, the sampling rate is a concern. To avoid aliasing frequencies higher than the Nyquist rate, $\frac{1}{2}$ the sampling frequency must be filtered and reduced in amplitude to less than 1 LSB of the ADC. In this example, a 12-bit ADC is being used with a 4.096V reference, which results in a resolution of 1 mV as follows:

$$\frac{4.096 \text{ V}}{4096} = 0.001 \text{ V}$$

To have a realizable filter in sampled data systems, there must be some separation between the highest frequency to be measured and the Nyquist frequency of the ADC. The result is over sampling the signal, but the filter can reduce or eliminate aliasing. *Figure 1* uses the ADC121S021, which is a 12-bit, 200k Samples Per Second (kSPS) ADC. When this ADC is converting at 200 kSPS, the Nyquist frequency will be 100 kHz. The output signal of the sensor is about 8 mV_{P-P} at 100 kHz and the gain required to reduce this signal to less than 1 mV_{P-P} is:

$$20 \log \left(\frac{0.001 \text{ V}}{0.008 \text{ V}} \right) = -18 \text{ dB}$$

The difference between the 100 kHz and the 40 kHz signal is:

$$\log(100 \text{ kHz}) - \log(40 \text{ kHz}) = 5 - 4.60 = 0.40 \text{ decade}$$

At 40 kHz, the gain is:

$$20 \log \left(125 \frac{\text{V}}{\text{V}} \right) = 41.9 \text{ dB}$$

The required filter roll off is:

$$\frac{(-41.9 \text{ dB} + (-18 \text{ dB}))}{0.4 \text{ decade}} = -149.8 \text{ dB/decade}$$

Or at least an 8-pole filter:

$$\frac{-149.8 \text{ dB/decade}}{-20 \text{ dB/decade/pole}} = 7.5 \text{ poles}$$

An amplifier can easily implement a 2-pole filter with four amplifiers having a pass band gain of five and another amplifier with a pass band gain of one.

Signal-Path Solutions for Industrial Diagnostics and Factory Automation

Ultrasonic Receiver and Spectral Analyzer

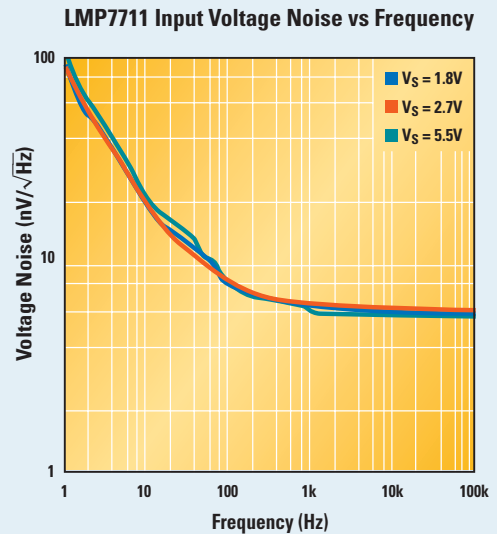
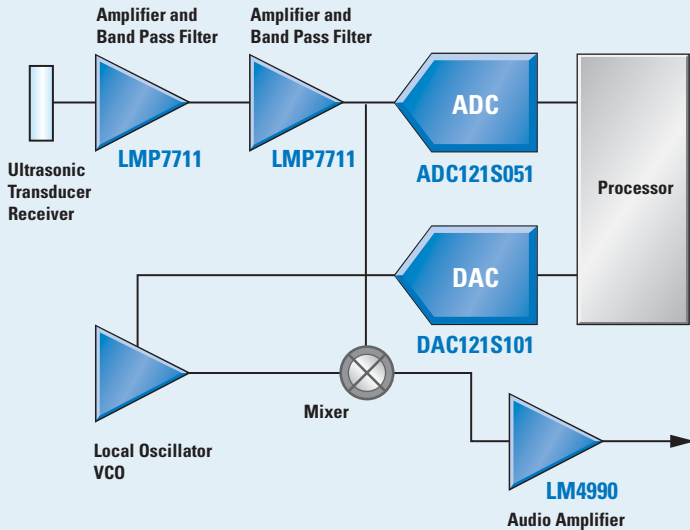

LMP7711 Features

- Offset voltage, V_{OS} , less than 150 μV for better initial accuracy
- Maximum TCV_{OS} of 4 $\mu\text{V}/^\circ\text{C}$ ensures accuracy from -40°C to 125°C
- Low $1/f$ noise at 6.8 $\text{nV}/\sqrt{\text{Hz}}$ at 1 kHz
- Ultra-low input bias current, 100 fA, for high impedance sensor interfacing

LMP7701 Features

- Offset voltage, V_{OS} , less than 300 μV for better initial accuracy
- Guaranteed 2.7V to 12V operation over -40°C to 125°C
- Ultra-low input bias current, 200 fA, for high impedance sensor interfacing
- High PSRR (110 dB) ensures higher accuracy with noisy supplies
- High CMRR (110 dB) ensures high accuracy over a wide input range

Precision Op Amps

Product ID	Key Features	Typ Supply Current (mA)	Supply Voltage Range (V)	Max Input Offset Voltage (mV)	Unity Gain Bandwidth (MHz)	Low Input Current CMOS Design	Temp Range ($^\circ\text{C}$)
LMP7711	Precision, low-noise RRIO CMOS	1.15	1.8 to 5.5	0.15	17	✓	-40 to +125
LMP7701	Precision, 12V RRIO CMOS	0.73	2.7 to 12	0.2	2.5	✓	-40 to +125
LMV651	90% Power saving RRIO performance amp	0.11	2.7 to 5.5	1.0	12	—	-40 to +125
LMV791	Low-noise, low I_{BIAS} RRIO	0.95	1.8 to 5.5	1.3	14	✓	-40 to +125
LPV511	880 nA, Ultra-low power 12V RRIO	880 nA	2.7 to 12	3.0	0.027	—	-40 to +85

Distance and Speed Measurement Application

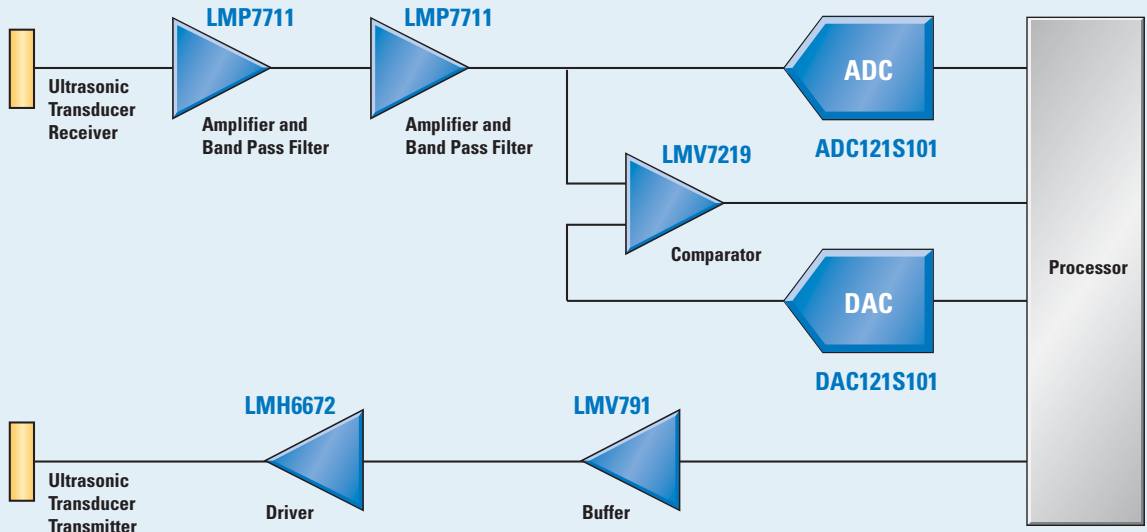

Serial Peripheral Interface (SPI) ADCs and DACs for Single-Channel Applications

- Guaranteed performance over sample rates
- Excellent static and dynamic performance
- Miniature packages reduce board space
- Pin- and function-compatible family
- Extremely low power
- Reference from supply

ADCs for Single-Channel Applications

Product ID	Res	# of Inputs	Pin/Function Compatible	Throughput Rate (kSPS)	Input Type	Max Power 5V/3V (mW)	Supply (V)	Max INL (LBS)	Min SINAD (dB)	Packaging
ADC121S101	12	1	↑ ↓	500 to 1000	Single ended	16/4.5	2.7 to 5.25	±1.1	70	SOT23-6, LLP-6
ADC121S051	12	1		200 to 500	Single ended	15.8/4.7	2.7 to 5.25	±1.0	70.3	SOT23-6, LLP-6
ADC121S021	12	1		50 to 200	Single ended	14.7/4.3	2.7 to 5.25	±1.0	70	SOT23-6, LLP-6
ADC101S101	10	1		500 to 1000	Single ended	16/4.5	2.7 to 5.25	±0.7	61	SOT23-6
ADC101S051	10	1		200 to 500	Single ended	13.7/4.3	2.7 to 5.25	±0.7	60.8	SOT23-6
ADC101S021	10	1		50 to 200	Single ended	12.6/4	2.7 to 5.25	±0.6	60.7	SOT23-6
ADC081S101	8	1		500 to 1000	Single ended	16/4.5	2.7 to 5.25	±0.3	49	SOT23-6
ADC081S051	8	1		200 to 500	Single ended	12.6/3.6	2.7 to 5.25	±0.3	49	SOT23-6
ADC081S021	8	1		50 to 200	Single ended	11.6/3.24	2.7 to 5.25	±0.3	49	SOT23-6
ADC121S625*	12	1			50 to 200	Differential	2.8	4.5 to 5.5	±1.0	68.5

*Uses external reference

DACs for Single-Channel Applications

Product ID	Res	# of Inputs	Pin/Function Compatible	Settling Time (µs)	Input Type	Max Power 5V/3V (mW)*	Supply (V)	Max INL (LBS)	Max DNL (LBS)	Packaging
DAC121S101	12	1	↑ ↓	10	Single ended	1.5/0.7	2.7 to 5.5	±8.0	+1.0/-0.7	SOT23-6, MSOP-8
DAC101S101	10	1		7.5	Single ended	1.6/0.7	2.7 to 5.5	±2.8	+0.35/-0.2	SOT23-6, MSOP-8
DAC081S101	8	1		5	Single ended	1.6/0.7	2.7 to 5.5	±0.75	±0.1	SOT23-6, MSOP-8

*F_{SCLK} = 20 MHz

Machinery Monitoring

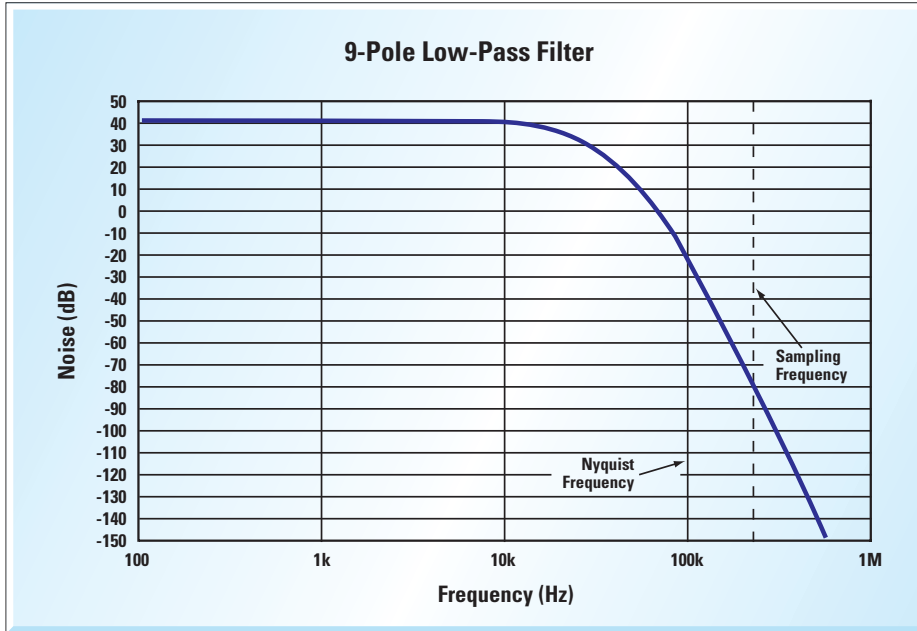

Figure 3. 9-Pole Low-Pass Filter

The filter's pass band characteristic is a result of the amplifier's gain bandwidth and the placement of the poles in the amplifier's feedback. Each filter stage can be considered as a non-inverting gain stage of 5V/V with two poles. The gain bandwidth of the amplifier required to keep the amplitude error less than 1 LSB at 40 kHz can be calculated as follows:

$$\frac{40 \text{ kHz} \times 5}{0.0156} = 12820 \text{ kHz} = 12.8 \text{ MHz}$$

The denominator, 0.0156, in the previous calculation is the effective bandwidth of an amplifier for 13-bit accuracy given its -3 dB point. The LMP7711 precision amplifier, with 17 MHz gain bandwidth and a typical offset voltage of 20 μV , is a good choice for this type of application. The output of amplifier A3 is isolated from the switched capacitor input of the ADC by the 180 Ω resistor and the 470 pF capacitor which adds an additional pole to the anti-alias filter. *Figure 3* shows the estimated response of the low-pass filter.

The ADC121S021 is a single-ended input, 12-bit, 200 kSPS converter with a Serial Peripheral Interface

(SPI). An LM4140ACM-4.1 precision voltage reference is the ADC's reference and biases the filter amplifiers to half of the ADC's input range. The sensor's output is an AC signal, and the mid-scale offset level shifts the signal to the center of the ADC's range. The LM4140 is also the reference voltage for the voltage controlled current source using the LM7301, amplifier A4, a general purpose 32V amplifier. Internal to the sensor, a MOSFET transistor buffers the piezoelectric sensor element. The current source drives the MOSFET, which is connected as a common source amplifier and is AC coupled to the output terminal.

Another aspect of machine monitoring is the measurement and analysis of hydraulic pressure transients in hydraulic control systems. For example, hydraulic hammer occurs when flow control valves have a fast shutoff and the fluid momentum causes a banging effect within the fluid system. Hydraulic hammer can damage and cause premature failure of hydraulic components and systems. These systems are designed to safely absorb the hydraulic energy. *Figure 4* is a schematic of a hydraulic pressure monitoring system.

This signal chain can be used to monitor pressure fluctuations as well as to conduct spectral analysis of the pressure fluctuations. As in *Figure 1*, the frequency response of the sensor and amplifier must eliminate frequency components above the Nyquist frequency. In this case, the frequency response of the pressure sensor and the hydraulic system naturally band limit the pressure signals to about 3 kHz to 4 kHz. This reduces the filter requirements of the amplifier circuits. This amplifier, made up of A1 and A2, is the input stage of an instrumentation amplifier and provides a differential input and a differential output with a gain of 100V/V. The 200 pF capacitors provide a pole at 8 kHz for additional filtering. The amplifiers' outputs are isolated from the switched capacitor inputs of the ADC by the 180Ω resistors and the 470 pF capacitors.

The pressure sensor in this example is a resistive bridge and the sensor's output is a function of the change in resistance and the voltage driving it. The sensor used in *Figure 3* has a sensitivity of 0.2 mV/V of bridge excitation voltage per PSI of pressure. The DAC081S101 is an 8-bit DAC and is used to change the voltage driving the bridge which has the effect of a gain control for the pressure measurement circuit. For example, if the DAC's output is programmed to 4V, then the full-scale pressure is 25.6 PSI. With an output voltage of 1V, the full-scale pressure is 102 PSI.

In summary, the circuitry shown can be used to implement a cost-effective, dedicated machine monitoring system. ■

View over 50 on-demand design focused seminars at www.national.com/onlineSeminar

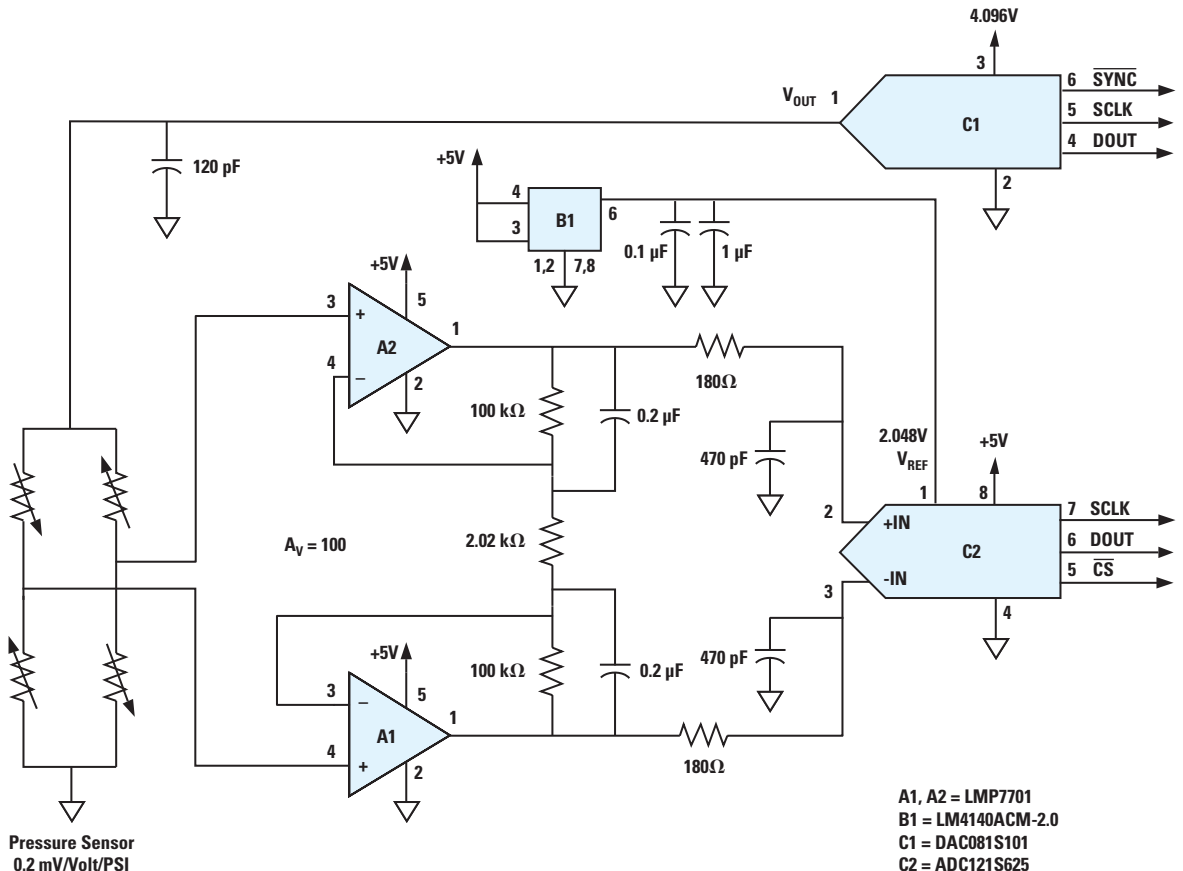
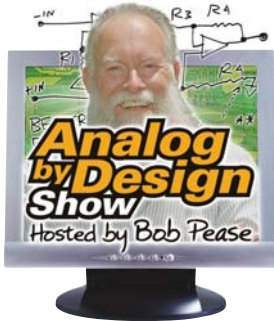

Figure 4. Hydraulic Pressure Monitoring System

Design Tools

INTRODUCING...



The Analog by Design Show

Tune in to National's Analog by Design Show, hosted by Bob Pease, for in-depth technical discussion and lab demonstrations including:

- How not to design a noise-amplifying preamplifier
- How to properly specify a low-noise op amp
- How to test whether an op amp model includes effects of noise
- New WEBENCH® Low-Pass Active Filter Evaluation Board
- Compare WEBENCH simulation results with bench-test results

WEBENCH Active Filter Designer speeds the creation of sophisticated filters for data acquisition and signal conditioning applications.

Check out the new episode at www.national.com/nationaltv

WaveVision 4.0 Evaluation Board

Test and evaluate A/D converters with National's easy-to use WaveVision 4.0 evaluation board. Each evaluation board comes complete with USB cable and support software.

Features and benefits:

- Plug-n-play ADC evaluation board
- USB interface to PC
- PC-based data capture
- Easy data capture and evaluation
- Highlighted harmonic and SFDR frequencies
- Easy waveform examination
- Produces and displays FFT plots
- Dynamic performance parameter readout with FFT
- Produces and displays histograms



National Semiconductor

2900 Semiconductor Drive
PO Box 58090
Santa Clara, CA 95052
1 800 272 9959

Visit our website at:
signalpath.national.com

For more information,
send email to:
new.feedback@nsc.com

Don't miss a single issue!

Subscribe now to receive email alerts when new issues of Signal Path DesignerSM are available:

signalpath.national.com/designer

Also, be sure to check out our Power Designer! View online today at:

power.national.com/designer

