



1.0 Design Specifications

Inputs	Outputs #1
VinMin=-48	Vout1=13.5
VinMax=-48	Iout1=1.5

2.0 Design Description

The LM5020 is employed here to design a Buck-Boost type power supply where the absolute value of the negative input voltage rail can be above or below the positive output voltage rail. The LM5020 is a versatile pwm controller requiring an external FET switch, Q101, which is sized to fit the output current requirement. The input voltage, Vin, during the on-time of the switch charges the L100 inductor through the FET from ground to the negative rail. During the off-time of the FET switch the inductor reverses polarity to forward bias the diode D100 to charge the output capacitors to the required output

voltage and provide current to the load. The output voltage is set by the loop using a current sourcing circuit, Q100 & R103, to develop a feedback voltage across R111. The loop transient response is governed by the resistor capacitor circuit across the feedback pin, VFB, and the compensation pin, COMP, of the controller IC. Output capacitors, C1,106,C107 are set to limit ripple and noise voltage while the input capacitance limits the noise ripple effects found on the input rail. The softstart ramp is optimized through C108 and the switching frequency is set via R105. The current in the loop is sensed across resistor R108 to afford current mode operation and cycle to cycle current limiting.

3.0 Schematic

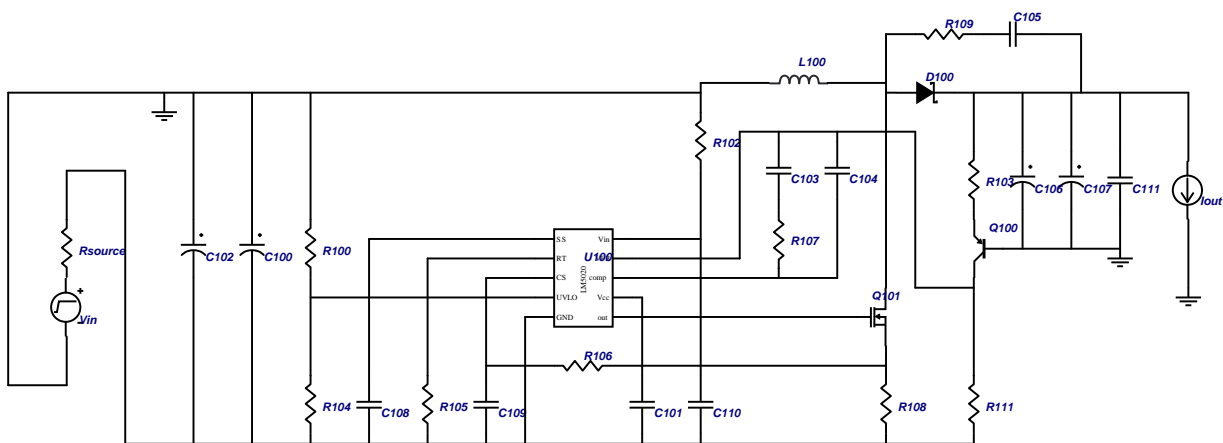

689758_695_0

FIGURE 1. Example Schematic Showing Connection for all Components.

4.0 Bill Of Materials

Part	Manufacturer	Part#	Attributes
C100	Sanyo	63MV220AX	220u F, 0.26 Ohms
C101	TDK	C2012X7R1C105	1u F
C102	Sanyo	63MV220AX	220u F, 0.26 Ohms
C103	Vishay	VJ0805Y473KXXAT	47n F
C104	Vishay	VJ0805A221KXXAT	220p F
C105	Vishay	VJ0805A101KXXAT	100p F
C106	Sanyo	25MV220WX	220u F, 0.17 Ohms
C107	Sanyo	25MV220WX	220u F, 0.17 Ohms

Part	Manufacturer	Part#	Attributes
C108	Vishay	VJ0805Y103KXXAT	0.01u F
C109	Vishay	VJ0805A102KXXAT	1000p F
C110	Vishay	VJ0805A101KXXAT	0.1u F
C111	Vishay	VJ0805A101KXXAT	0.1u F
D100	ONSEMI	MBRS3100T3	0.79 V
L100	Coilcraft	DO5010P-223HC	22u H, 0.047 Ohms
Q100	Vishay	MMBTA56/E8	
Q101	Vishay	Si7810DN	
R100	Vishay	CRCW08053323FRT6	332k Ohms
R102	Vishay	CRCW080510R0FRT6	10 Ohms
R103	Vishay	CRCW08055112FRT6	51.1k Ohms
R104	Vishay	CRCW08051002FRT6	10k Ohms
R105	Vishay	CRCW08052612FRT6	26.1k Ohms
R106	Vishay	CRCW08053010FRT6	301 Ohms
R107	Vishay	CRCW08051243FRT6	124k Ohms
R108	Vishay	WSL1206-18 0.068 1%	0.068 Ohms
R109	Vishay	CRCW08051000FRT6	100 Ohms
R111	Vishay	CRCW08054991FRT6	4.99k Ohms
U100			

National Semiconductor's design tools attempt to recreate the performance of a substantially equivalent physical implementation of the design. Reference designs are created using National's published specifications as well as the published specifications of other device manufacturers. While National does update this information periodically, this information may not be current at the time the reference design is built. National and/or its licensors do not warrant the accuracy or completeness of the specifications or any information contained therein. National and/or its licensors do not warrant that any designs or recommended parts will meet the specifications you entered, will be suitable for your application or fit for any particular purpose, or will operate as shown in the simulation in a physical implementation. National and/or its licensors do not warrant that the designs are production worthy. You should completely validate and test your design implementation to confirm the system functionality for your application.

National does not assume any responsibility for use of any circuitry described, no circuit patent licenses are implied and National reserves the right at any time without notice to change said circuitry and specifications.

For the most current product information visit us at www.national.com.

LIFE SUPPORT POLICY

NATIONAL'S PRODUCTS ARE NOT AUTHORIZED FOR USE AS CRITICAL COMPONENTS IN LIFE SUPPORT DEVICES OR SYSTEMS WITHOUT THE EXPRESS WRITTEN APPROVAL OF THE PRESIDENT AND GENERAL COUNSEL OF NATIONAL SEMICONDUCTOR CORPORATION. As used herein:

- Life support devices or systems are devices or systems which,
 - are intended for surgical implant into the body, or
 - support or sustain life, and whose failure to perform when properly used in accordance with instructions for use provided in the labeling, can be reasonably expected to result in a significant injury to the user.
- A critical component is any component of a life support device or system whose failure to perform can be reasonably expected to cause the failure of the life support device or system, or to affect its safety or effectiveness.

BANNED SUBSTANCE COMPLIANCE

National Semiconductor certifies that the products and packing materials meet the provisions of the Customer Products Stewardship Specification (CSP-9-111C2) and the Banned Substances and Materials of Interest Specification (CSP-9-111S2) and contain no "Banned Substances" as defined in CSP-9-111S2.

Leadfree products are RoHS compliant.



National Semiconductor Americas Customer Support Center
 Email: new.feedback@nsc.com
 Tel: 1-800-272-9959

National Semiconductor Europe Customer Support Center
 Fax: +49 (0) 180-530-85-86
 Email: europe.support@nsc.com
 Deutsch Tel: +49 (0) 69 9508 6208
 English Tel: +49 (0) 870 24 0 2171
 Français Tel: +33 (0) 1 41 91 8790

National Semiconductor Asia Pacific Customer Support Center
 Email: ap.support@nsc.com

National Semiconductor Japan Customer Support Center
 Fax: 81-3-5639-7507
 Email: jpn.feedback@nsc.com
 Tel: 81-3-5639-7560