

REVISIONS				
LTR	DESCRIPTION	E.C.N.	DATE	BY/APP'D
A	RELEASE TO DOCUMENT CONTROL	393	07/27/2001	MS/AP

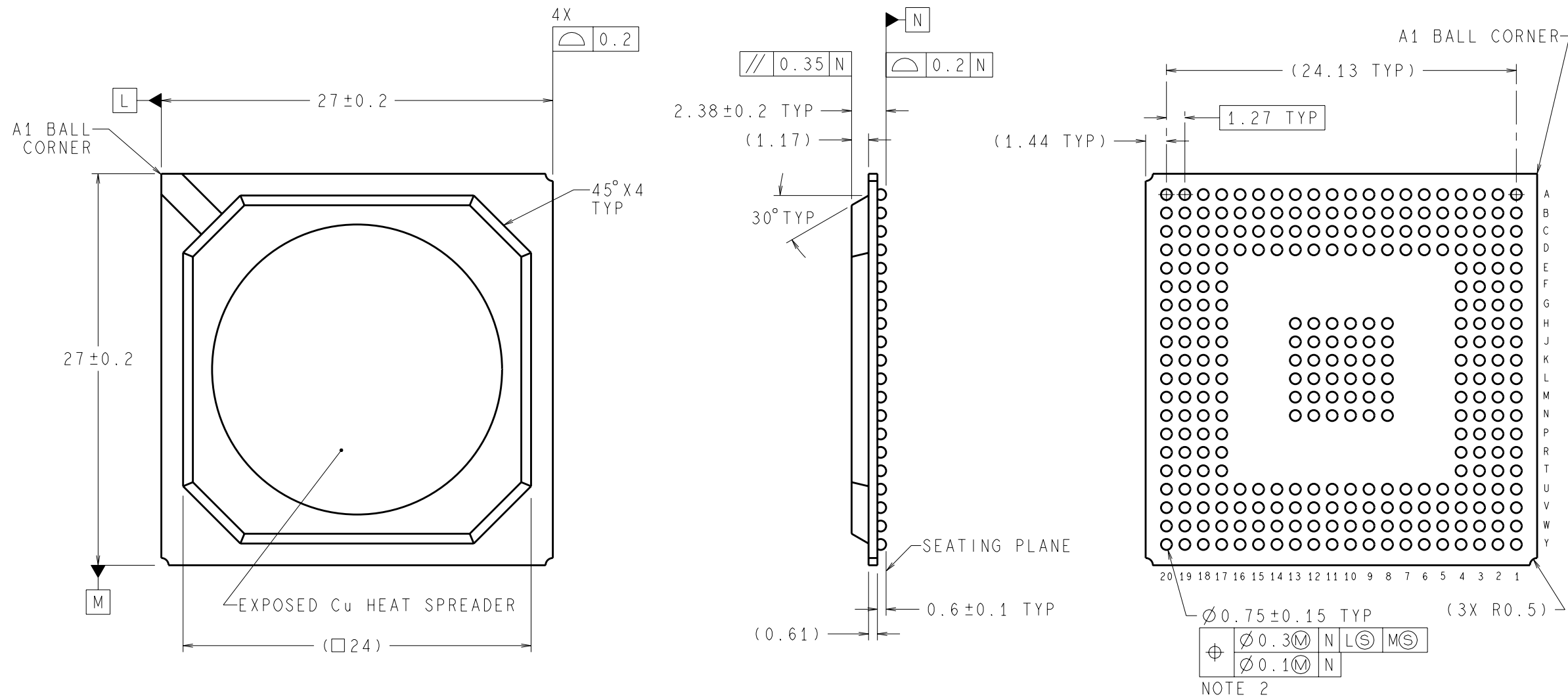

DIMENSIONS ARE IN MILLIMETERS

NOTES: UNLESS OTHERWISE SPECIFIED

- SOLDER BALL COMPOSITION: Sn 63%, Pb 37%.
- DIMENSION IS MEASURED AT THE MAXIMUM SOLDER BALL DIAMETER, PARALLEL TO PRIMARY DATUM N.
- THE MOLD SURFACE AREA MAY INCLUDE DIMPLE FOR A1 BALL CORNER IDENTIFICATION.
- REFERENCE JEDEC REGISTRATION MS-034, VARIATION BAL-2.

APPROVALS	DATE	 2900 Semiconductor Dr., Santa Clara, CA 95052-8090			
DRAWN MARTA SUCHY	07/27/2001				
DFTG. CHK. THANH LEQUANG	07/27/2001	TE-PBGA, 27 X 27 X 2.38mm, 292 BALL, 1.27mm PITCH			
ENGR. CHK. ANINDYA PODDAR	07/27/2001				
 PROJECTION INCH [MM]		SCALE	SIZE	DRAWING NUMBER	REV
		N/A	C	MKT-UFH292A	A
DO NOT SCALE DRAWING				SHEET 1 of 1	