

REVISIONS				
REV	DESCRIPTION	E.C.N.	DATE	BY/APP'D
A	RELEASE TO DOCUMENT CONTROL	12202	04/28/1999	MS/ECH
B	DIM 0.125/0.05 WAS 0.06/0.04; FLATTEN BUMP HEIGHT BY 0.005mm; X3 TOL 100 WAS 50.	174	10/04/2000	MS/VA
C	CHANGE BUMPS NUMBERING ORDER PER JEDEC; UPDATE NOTE 4.	524	02/06/2002	MS/VP
D	DIM 0.15/ 0.11 WAS 0.14/ 0.11; REVISE NOTES 2 & 5; ADD '2' 1234 & '1' 1259 TO X1 & X2 COLUMNS; CHANGE DWG FORMAT TO B SIZE.	838	01/12/2004	MS/HN

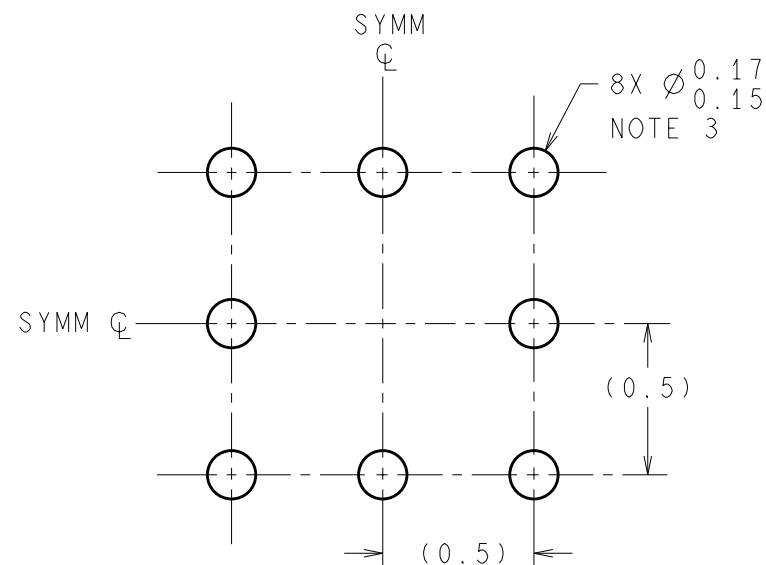

DIMENSIONS ARE IN MILLIMETERS
DIMENSIONS IN () FOR REFERENCE ONLY

LAND PATTERN RECOMMENDATION

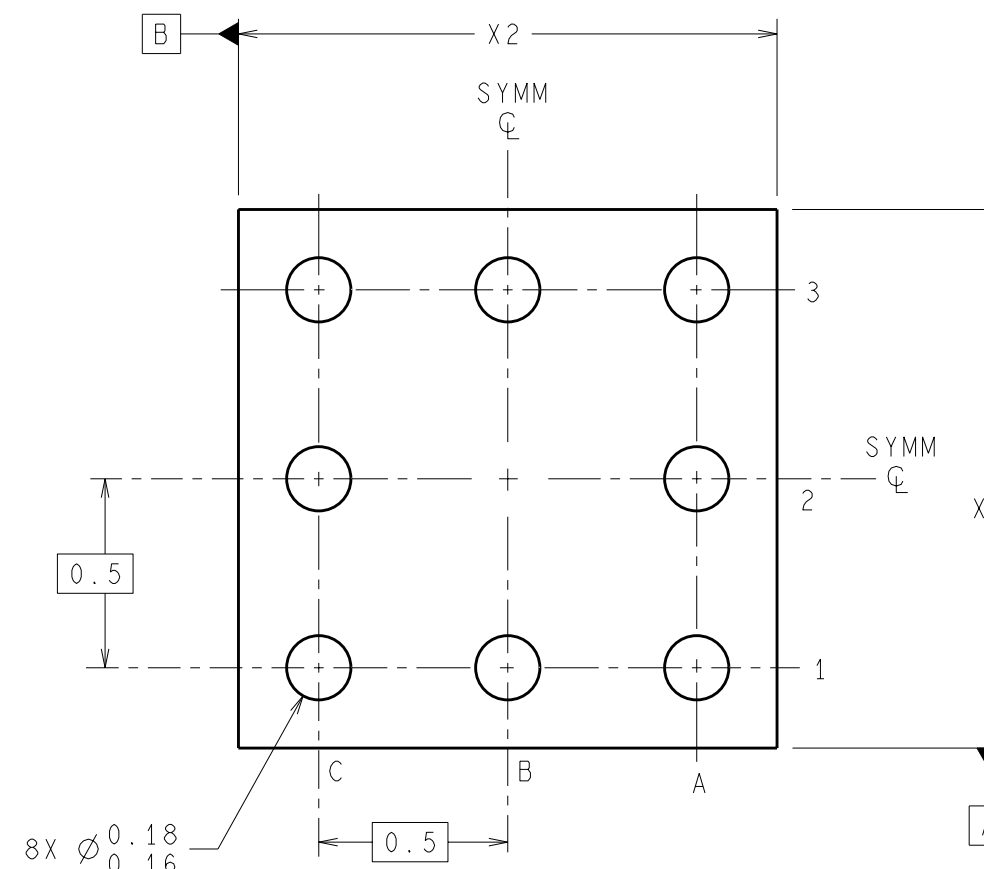
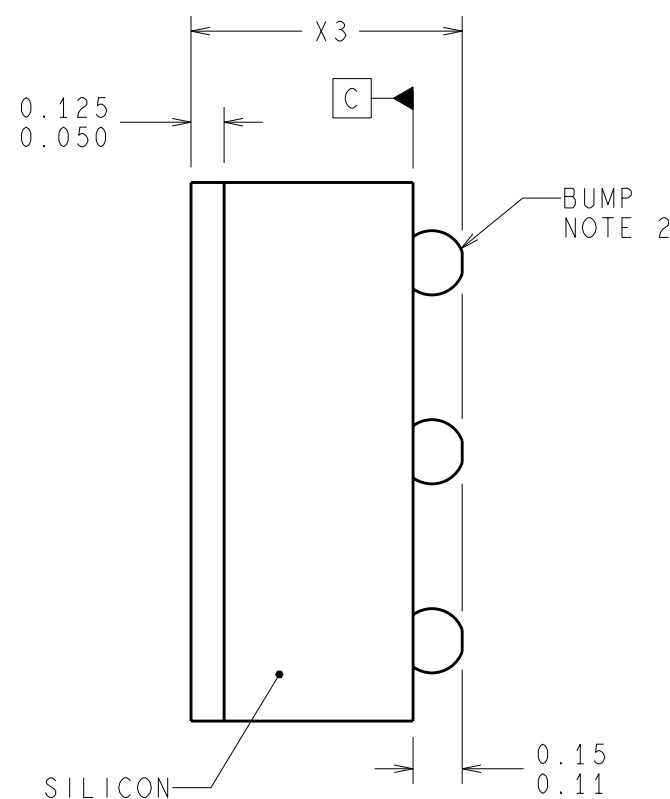
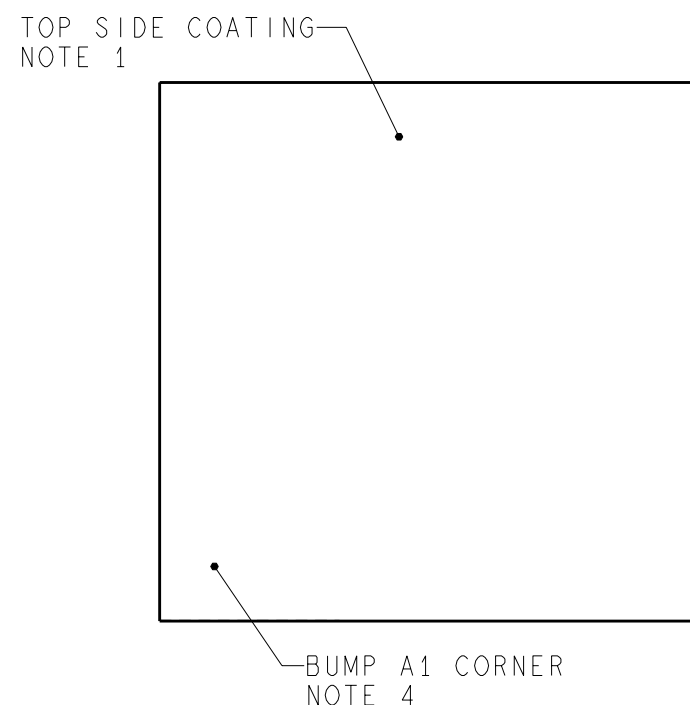

\varnothing	0.005	S	C	A	S	B	S
---------------	-------	---	---	---	---	---	---

NOTES: UNLESS OTHERWISE SPECIFIED

- EPOXY COATING.
- FOR SOLDER BUMP COMPOSITION, SEE "SOLDER INFORMATION". IN THE PACKAGING SECTION OF THE NATIONAL SEMICONDUCTOR WEB PAGE (www.national.com).
- RECOMMEND NON-SOLDER MASK DEFINED LANDING PAD.
- PIN A1 IS ESTABLISHED BY LOWER LEFT CORNER WITH RESPECT TO TEXT ORIENTATION.
- XXX IN DRAWING NUMBER REPRESENTS PACKAGE SIZE VARIATION WHERE X1 IS PACKAGE WIDTH, X2 IS PACKAGE LENGTH AND X3 IS PACKAGE HEIGHT (SEE TABLE, SHEET 2).
- REFERENCE JEDEC REGISTRATION MO-211, VARIATION BC.

APPROVALS		DATE	National Semiconductor	
DRAWN	MARTA SUCHY	04/28/1999	2900 Semiconductor Dr., Santa Clara, CA 95052-8090	
DFTG. CHK.	THANH LEQUANG	01/12/2004	MICRO SMD, 8 BUMP, 0.5mm PITCH	
ENGR. CHK.	HAU NGUYEN	01/12/2004		
PROJECTION	SCALE	SIZE	DRAWING NUMBER	REV
	NTS	B	(SC)MKT-BPA08XXX	D
MM	FORMERLY: N/A	SHEET 1 of 2		

REVISIONS				
REV	DESCRIPTION	E.C.N.	DATE	BY/APP'D
	SEE SHEET 1			

8 BUMP NOMINAL PACKAGE DIMENSIONS					
X1 DESIGNATOR	X1 PACKAGE WIDTH ($\pm 30\mu\text{m}$)	X2 DESIGNATOR	X2 PACKAGE LENGTH ($\pm 30\mu\text{m}$)	X3 DESIGNATOR	X3 PACKAGE HEIGHT ($\pm 75\mu\text{m}$)
Z	1234	Z	1234	A	700
1	1259	1	1259	B	850
A	1285	A	1285	C	900
B	1311	B	1311		
C	1336	C	1336		
D	1361	D	1361		
E	1387	E	1387		
F	1412	F	1412		
G	1438	G	1438		
H	1463	H	1463		
J	1488	J	1488		
K	1514	K	1514		
L	1539	L	1539		
M	1565	M	1565		
N	1590	N	1590		
P	1615	P	1615		
Q	1641	Q	1641		
R	1666	R	1666		
S	1692	S	1692		
T	1717	T	1717		
U	1742	U	1742		
V	1768	V	1768		
W	1793	W	1793		
X	1819	X	1819		
Y	1844	Y	1844		
2	1869	2	1869		
3	1895	3	1895		
4	1920	4	1920		
5	1946	5	1946		
6	1971	6	1971		

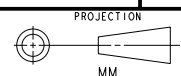
APPROVALS		DATE	 2900 Semiconductor Dr., Santa Clara, CA 95052-8090			
DRAWN	MARTA SUCHY	04/28/1999				
DFTG. CHK.	THANH LEQUANG	01/12/2004				
ENGR. CHK.	HAU NGUYEN	01/12/2004				
 PROJECTION MM			SCALE	SIZE	DRAWING NUMBER	REV
			NTS	B	(SC)MKT-BPA08XXX	D
FORMERLY: N/A			SHEET 2 of 2			