

The LMH6555 differential amplifier is designed to drive the 100W differential input of GigaSample per second (GSPS) A/D Converters (ADCs) with up to 0.8 V_{P-P}, and to present constant 50Ω input impedance to the terminating cable to achieve the highest return loss. This amplifier can be used either as a single-ended input to differential output, or simply as a differential-input/output driver. The mostly widely used application is in DC-coupled (or wideband) applications where a single-ended input is to be sampled by a high-speed differential input ADC. Compared to balun transformers, which are often used to perform this function, the LMH6555 offers several advantages: Common Mode (CM) voltage can be set (needed for ADC DC coupling), the ability to provide voltage gain, it can be DC-coupled (Baluns must be AC-coupled), the output voltage swing is matched with inputs of GSPS ADCs, and there is higher input return-loss by maintaining 50Ω input impedance to ground over a wide frequency range, and better gain balance.

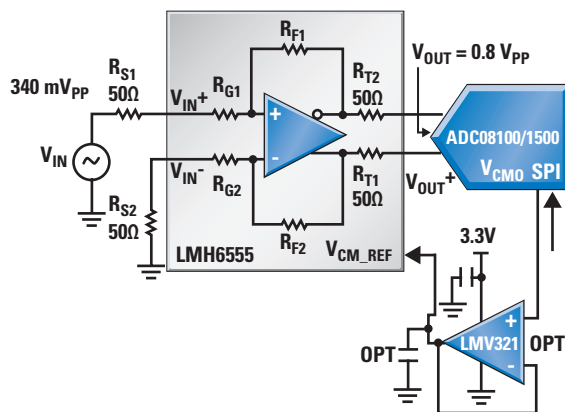

Figure 1. Active Single Ended to Differential Conversion for Broadband Applications

The LMH6555 spans the frequency range from DC up to 1.2 GHz (-3 dB bandwidth limit of the LMH6555). Accurate output CM voltage control is maintained by tying the V_{CMO} of the ADC to the V_{CM_REF} input of the LMH6555. This enables the capture of the full signal

spectrum while the LMH6555 automatically maintains common mode control. The buffer (LMV321) shown in *Figure 1* boosts the current out of the ADC V_{CMO} pin so there is adequate drive for the V_{CM_REF} input. This buffer may or may not be needed, depending on the output current capability of the ADC. Most other commercially available drivers have a similar output CM control scheme, though the adjustment range of each is different and is closely related to the range of voltages expected by the intended ADC.

For AC-coupled applications, ADC inputs are internally biased and there is no need for common mode feedback control. For these applications, the ADC V_{CMO} is grounded and the ADC inputs are internally biased. The LMH6555 V_{CM_REF} pin needs to be biased to ~1.2V DC using a crude voltage divider from the 3.3V supply. The LMH6555's gain (differential output to single ended input) is fixed at 4.7 V/V (see *Figure 1*) where R_{S1}=R_{S2}=50Ω. This gain includes the loading of the ADC (100W in this case) onto the driver's 50Ω outputs. When the input signal is larger in amplitude, lower the LMH6555 insertion gain by increasing the value of R_{S2} and R_{S1}. These two resistors should always be equal in order to keep the input balance for low output offset. In *Figure 2*, the gain of the LMH6555, which is at the receiving end of a 50Ω cable, is reduced using R_X and R_Y. By proper selection of component values, the input impedance to the LMH6555 circuitry (at J1) is kept at 50Ω to maintain impedance matching. For low output offset voltage, the LMH6555 architecture requires good matching between the equivalent external impedances looking to each input.

The input/output swing relationship of the LMH6555 is shown in *Equation 1*:

$$V_{OUT} (V_{P-P}) = V_{IN} (V_{P-P}) * [RF / (2R_S + R_{in_diff})]$$

Equation 1

where $RF = 430\Omega$ and $R_{IN_diff} = 78\Omega$ and are LMH6555 specific values.

R_S is the equivalent resistance that each of the LMH6555 inputs sees to ground (assuming that they are equal to each other). Increasing R_S will reduce the gain. The ADC shown requires $0.8 V_{P-P}$ across inputs.

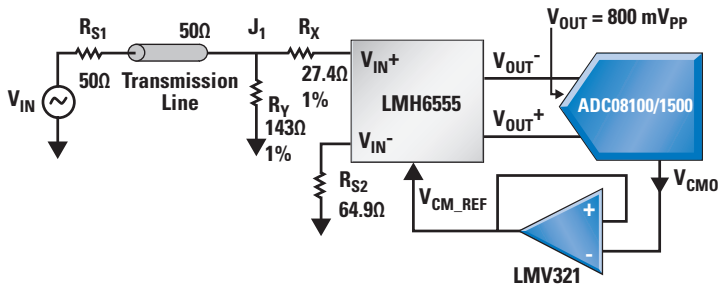

Figure 2. Setting the LMH6555 Gain while Maintaining Matched Input Impedance

Figure 2 is an example where the single-ended input is driven by a 50Ω transmission line that needs 50Ω to ground for proper termination. The series and shunt resistances, R_X and R_Y , present the proper cable termination (50Ω) and achieve the correct Thevenin resistance (64.5Ω) so that there is $0.8 V_{P-P}$ generated across the ADC inputs. In *Equation 1*, “ $V_{IN} (V_{P-P})$ ” would be the Thevenin equivalent voltage of the input network (R_{S1} , R_Y , and R_X) Thevenin equivalent resistance:

$$V_{Th} = 0.52V_{P-P} \cdot R_Y / (R_Y + R_{S1}) = 0.385V_{P-P}$$

$$R_{Th} = R_X + 1 / (1/R_{S1} + 1/R_Y) = 64.5\Omega$$

You can use a spreadsheet to arrive at the proper values of R_X and R_Y in *Figure 2*. Use “goal seek” find the value of R_X which would allow $0.8 V_{P-P}$ output swing. Similarly, R_Y can be adjusted for 50Ω input

termination. Repeating this procedure will generate the resistor values needed. The LMH6555 maintains its low noise ($19 \text{ nV}/\sqrt{\text{Hz}}$ output referred flat-band) irrespective of the R_S on its inputs because the input architecture is dominated by its equivalent input noise voltage and is independent of the source resistance.

Most amplifier-ADC interfaces require the use of series resistance and shunt capacitance in order to improve the transient response due to charge switching on the input of the ADC. In the case of the LMH6555 and its interface to National’s ADC08xxxx family, the amplifier-ADC connection does not require this RC network because the LMH6555 has built-in series output resistances on each output to provide load isolation.

The ADC shown here requires that the CM voltage of the differential inputs be very close (within $\pm 50 \text{ mV}$) to the V_{CM0} reference output it generates. This is one consequence of its 1.9V operating supply voltage because it constricts the voltage headroom of the ADC internal circuitry. If this CM operating condition is not maintained, the ADC full scale distortion performance will suffer.

Summary

Single ended to differential conversion of signals for interface to high-speed ADCs is a challenging task and should not be overlooked when high performance is required. This application note has examined some of the considerations and challenges of the input signal interface and has introduced one of the National’s offerings (LMH6555) to alleviate this important task. Additional differential drivers intended for ADC interface include the LMH6550/51/52. ■

National Semiconductor
2900 Semiconductor Drive
Santa Clara, CA 95051
1 800 272 9959

Mailing Address:
PO Box 58090
Santa Clara, CA 95052

For Additional Design Information
edge.national.com