

# ANALOG | edge<sup>SM</sup>

## Powering and Dimming High-Brightness LEDs with the LM3405 Constant-Current Buck Regulator

Application Note AN-1644

Vinit Jayaraj, Principal Design Engineer

The LM3405 is a 1A, constant-current buck regulator designed to provide a simple, highly-efficient solution for powering LEDs with the highest power density. The low-feedback reference voltage of 205 mV (typical) allows the use of LEDs with large forward voltages. The LM3405 LED driver comes with an integrated 1A high-side power switch, internal current limit, over-voltage protection and thermal shutdown. The LM3405 driver utilizes current-mode control with internal compensation offering ease-of-use and predictable, high-performance regulation over a wide range of operating conditions. This article describes a few of the many application solutions for the LM3405 LED driver. The LM3405 device is offered in a 6-pin Thin-SOT (TSOT) package and operates at an internal switching frequency of 1.6 MHz, allowing the use of small-value inductors, thereby saving board space.

### Typical Application Circuit

Figure 1 shows the typical application circuit using the LM3405 regulator driving a single LED. The boost voltage can be derived from  $V_{IN}$  or  $V_{OUT}$ . The BOOST to SW voltage (VBOOST-VSW) should never exceed the operating limit of 5.5V, and must be greater than 2.5V for optimum efficiency.

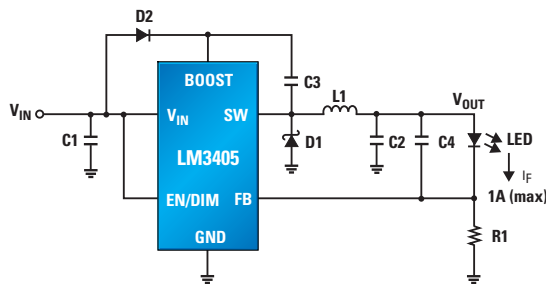

Figure 1. Typical Application Circuit

In the above circuit, the maximum  $V_{IN}$  is 5V and therefore the boost voltage is derived from  $V_{IN}$ . The LM3405 data sheet provides a detailed description of various circuits for boost-voltage generation. The LM3405 driver tightly regulates the FB-pin voltage to 205 mV (typical) and this allows the LED current ( $I_F$ ) to be set by the following equation:

$$I_F = \frac{205 \text{ mV}}{R1}$$

$R1$  (min) is 200 m $\Omega$  such that  $I_F$  (max) is limited to 1A. In case of an over current, the internal current limit will trigger and turn off the internal power switch on a cycle-by-cycle basis. In case of an over voltage (sensed at the FB pin), the internal power switch is turned off. The LM3405 regulator also has a built-in thermal shutdown (with hysteresis) which also turns off the internal power switch if the die temperature exceeds a typical value of 165°C.

### PWM Dimming Using the EN/DIM Pin

The LEDs can be dimmed by applying a PWM-logic signal to the EN/DIM pin of the LM3405 driver as shown in Figure 2.

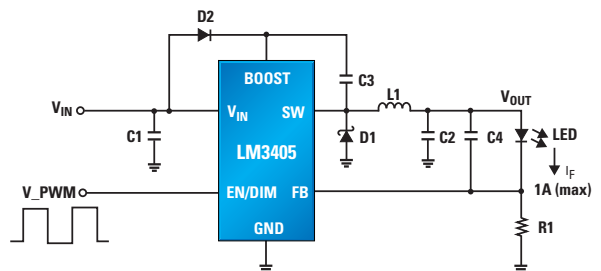
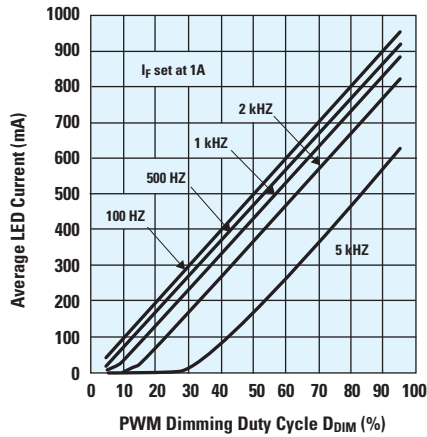

Figure 2. PWM Dimming of LEDs by Applying a PWM Signal to the EN/DIM Pin

A logic high at  $V\_PWM$  enables the IC, and a logic low disables the IC. In this manner, the LED current is turned on and off. In order to eliminate flicker, the lowest PWM-dimming frequency is normally chosen to be above 100 Hz. The upper end of the PWM frequency is determined by the turn-on delay of the LM3405. If the  $V\_PWM$  signal has an ON-time of  $T_{ON}$  and a period of  $T_{PER}$ , the average  $I_F$  is given approximately by the equation below. Note that the delay in enabling and disabling the IC is not included in the following equation. Typically the time delay from the instant where EN/DIM=1 to the instant where  $I_F$  is fully established is approximately 100  $\mu$ s (see Figure 4).

$$I_F \text{ (average)} = \frac{205 \text{ mV}}{R1} \times \left[ \frac{T_{ON}}{T_{PER}} \right]$$

The average LED current is therefore controlled by  $T_{ON}$ ,  $T_{PER}$ , or both and is perceived by the eye as a brightness change. *Figure 3* shows the measured average LED current for varying duty cycles and frequencies.



**Figure 3. Average LED Current versus Duty Cycle and Frequency of  $V_{PWM}$  at the EN/DIM Pin**

The startup delay of the LM3405 device is shown in *Figure 4* for an LED-current setting of 1A. This is the delay from the instant when EN/DIM=1 to the instant when  $I_F$  settles to 900 mA (90% of the set LED current).

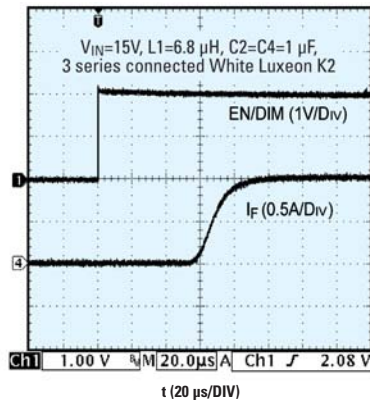
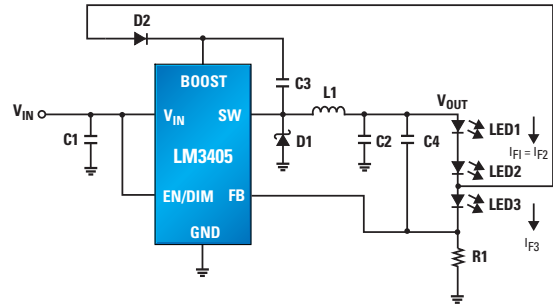

**Figure 4. Startup Response of the LM3405 to an EN/DIM Signal with  $I_F$  Set at 1A**

### Deriving a Self-Biased Boost Voltage When Driving Two or More LEDs in Series

In a typical application where two or more LEDs are driven in a single string, the boost voltage is derived from a separate, external low-voltage source so as to meet the  $(V_{BOOST}-V_{SW})$  voltage requirement. This is because when powering two or more LEDs in series,  $V_{IN}$  will be greater than 5V and therefore  $V_{IN}$  cannot be used to provide  $V_{BOOST}$ . In this case,  $V_{OUT}$  will also be high and cannot be used to derive  $V_{BOOST}$ .

*Figure 5* shows another approach for deriving a self-biased boost voltage from the LED string itself without the need for generating a separate low-voltage supply.



**Figure 5. Deriving a Self-Biased Boost Voltage from the LED String When Driving Two or More LEDs in Series**

The anode of the boost diode D2 is connected to the anode of LED3. The voltage at the anode of LED3 is approximately equal to 205 mV plus the forward voltage  $V_F$  of LED3. This voltage is approximately in the range of 3V to 4V (depending on the  $I_{F3}$  current setting) and meets the BOOST to SW voltage requirement. It must be noted that the current through LED1 and LED2 will be slightly larger than the current in LED3 due to the fact that the average charging current for the boost capacitor C3 will now be provided through LED1 and LED2. Therefore, the LED currents are:

$$I_{F3} = \left[ \frac{205 \text{ mV}}{R1} \right]$$

$$I_{F1} = I_{F2} = I_{F3} + \overline{I_{C3}}$$

where  $I_{F1}$ ,  $I_{F2}$ , and  $I_{F3}$  are the currents in LED1, LED2, and LED3, respectively and  $\overline{I_{C3}}$  is the average current charging C3 over one switching cycle. This approach can be used if exact current matching (and hence brightness) is not required between  $I_{F1}$  and  $I_{F3}$  or between  $I_{F2}$  and  $I_{F3}$ .

### Driving Multiple LED Strings with the LM3405 LED Driver

The LM3405 LED driver can be used to drive multiple LED strings in parallel as shown in *Figure 6*. The current in the primary branch (with LED1 and LED2) will be tightly regulated by the feedback loop.

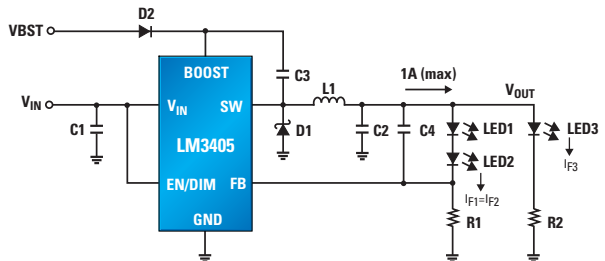

**Figure 6. Driving Multiple LED Strings**

The current in the secondary branch (with LED3) will be regulated based on  $V_{OUT}$ , forward voltage of LED3, and R2. The value of R2 can be adjusted to get the desired brightness for LED3.

$$I_{F1} = I_{F2} = \left[ \frac{205 \text{ mV}}{R1} \right] = I_{\text{PRIMARY}}$$

$$I_{F3} = \frac{205 \text{ mV} + V_{F1} + V_{F2} - V_{F3}}{R2} = I_{\text{SECONDARY}}$$

where  $V_{F1}$  and  $V_{F2}$  are the respective forward voltages of LED1 and LED2 at the primary current level, and  $V_{F3}$  is the forward voltage of LED3 at the secondary current level.  $I_{F1}$ ,  $I_{F2}$ , and  $I_{F3}$  are the currents in LED1, LED2, and LED3, respectively.

In *Figure 6*, VBST can be connected to an external DC source of 3V to 5V. VBST can also be derived from the cathode of LED3.

If VBST is derived from the cathode of LED3, this VBST can be written as (assuming  $V_{F1}=V_{F2}=V_{F3}=V_F=3.8\text{V}$ ):

$$VBST = 205 \text{ mV} + V_{F1} + V_{F2} - V_{F3} \cong 205 \text{ mV} + V_F \cong 4\text{V}$$

Note that the average current through LED3 will now be higher since the average current to charge C3 is supplied through LED3 as discussed in the previous section.

### Driving Parallel LEDs with the LM3405 LED Driver

Multiple LEDs can be paralleled and connected between  $V_{OUT}$  and FB as shown in *Figure 7*.

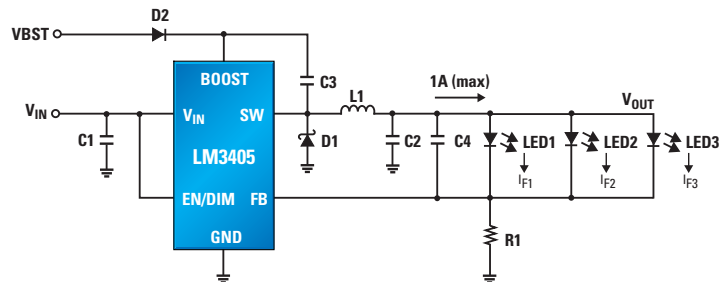

Figure 7. Driving Multiple LEDs in Parallel

The voltage at the FB pin is regulated to 205 mV by the control loop and therefore the current in R1 is fixed.  $V_{OUT}$  is determined by the LED with the highest forward voltage. This solution has the advantage of having a single resistor set the total currents in the LEDs but has no control of equal current sharing between the LEDs.

### Conclusion

This article describes a few application solutions using the LM3405 buck regulator. These solutions provide the user with highly-compact, driving and dimming solutions for high-brightness LEDs. The LM3405 data sheet may be referred to for a detailed description of operation and component design guidelines. ■

**National Semiconductor**  
2900 Semiconductor Drive  
Santa Clara, CA 95051  
1 800 272 9959

**Mailing Address:**  
PO Box 58090  
Santa Clara, CA 95052

