

# ANALOG | edge<sup>SM</sup>

## Keeping Up With the Expanding Demands of High-Performance Audio

Application Note AN-1651

Joe Curcio, Field Applications Engineer

Engineers designing audio equipment for the high-end audiophile or professional recording markets have a limited selection of high-resolution signal amplifiers that will meet end-user demands for both outstanding objective and critical subjective performance. Suitable devices must provide a combination of state-of-the-art specifications for low noise and ultra-low distortion along with high GBP and preferably unity gain stability. While nearly all suppliers develop and provide devices optimized for video, instrumentation, or low power, these applications demand a specification mix that does not necessarily align with the needs of the high-performance audio engineer. Accordingly, National Semiconductor has developed a series of high-performance, high-fidelity audio amplifiers specifically optimized for these applications.

The LME49710 / LM4562 are representative of this line of devices and have been optimized for the high performance and professional community. They provide the designer with unprecedented levels of THD (0.00003%) and IM (0.00005%) plus very low noise (2.7 nV /  $\sqrt{\text{Hz}}$ ) and GBWP of 55 MHz with output current of  $\pm 26$  mA into a 600 $\Omega$  load. Supply current is extremely low, serving the needs of both portable products as well as multimedia components utilizing multiple amplifiers.

This document will provide several design examples of high-performance applications using the LME49710/LM4562 that demonstrate their capability in meeting the demands of the highest audible performance.

Note that the design philosophy and choices discussed herein will frequently refer to the practices embraced by the professional and high-performance community as having both objective (measurable) as well as subjective (audible) merit. The quantification of the contribution of these techniques has been published in many other documents and will not be included in this document. Included in this approach are capacitor dielectric choices, power supply impedance considerations, and circuit topology.

Objectively, it is understood that best practices are required with device parameter consideration relative to circuit topology as well as grounding/shielding practices, power supply purity, and other well documented practices generally applied to sensor conditioning and instrumentation applications.

### RIAA Phono Pre-Amplifier

Phono amplifiers are utilized to amplify and equalize to the RIAA standard signal from magnetic phono cartridges. Although phono cartridge technology can be based on several forms of electrical generation, but in rare cases the highest quality are electro-magnetic using either a fixed coil (moving magnet) or fixed magnet (moving coil) designs. The moving magnet designs provide higher output voltages generally in the region of 1.0 mV for each cm/s tip of recorded velocity while moving coils deliver 0.1 mV under the same circumstances. Although this would seem to indicate that moving magnet is preferred (at least from the standpoint of the pre-amp designer), it is commonly accepted that the moving coil configuration provides superior audible performance most likely due to the lower mass of the cantilever assembly.

The key parameters of concern with RIAA equalized phono pre-amplifiers are low noise, low total harmonic distortion, low intermodulation distortion, and bandwidth. When interfacing with low output moving coil cartridges with source impedances of less than 100 $\Omega$ , the first amplifier should target an input noise voltage density of  $< 5$  nV /  $\sqrt{\text{Hz}}$ . Of course, THD and IMD should be as low as possible.

Although not commonly emphasized, a high PSRR across the full signal bandwidth is critical to the audible performance of the circuit. While the more commonly discussed specifications of distortion, noise, bandwidth and slew rate are important to characterize the performance of the amplifier, if one envisions an audio amplifier as a device that modulates the power supply current into the load in direct response to the input signal, it is clear that the power supply rails must present a low and more importantly flat impedance across the audio bandwidth to preserve the audible spectral balance and overall integrity of the input signal. The PSRR of the LME49710/ LM4562 is outstanding across the full audio bandwidth and therefore is highly immune to power supply impedance discontinuities. However, given the low level signals provided from moving coil

phono cartridges, the effect is more pronounced and therefore the impedance of the supply rails is addressed in this application.

In order to avoid the distortion contribution of coupling capacitors, the two circuit topologies presented will use direct coupling from input to output. Overall DC gain will be 74 dB (44 + 30) for the fully passive EQ design and 70 dB (44 + 26) for the active-passive EQ design. Typical  $V_{OS}$  of the LME49710 is 0.05 mV while  $I_{bias}$  is 7 nA. With the aforementioned DC gain, voltage offset at the output will typically be less than 1 volt. To compensate and provide for full DC coupling, servo offset amplifier U3 has been included.

Although we will not be discussing a fully active RIAA design, when this topology is used, the demands on slew rate and unity gain stability will intensify.

### RIAA Equalization

Table 1 shows the RIAA equalization response while Figure 1 displays the same graphically. The response is normally defined relative to 1 kHz with approximately 20 dB rise and attenuation relative to this frequency. The total dynamic range is actually greater than 40 dB as the high frequency rolloff continues beyond the second high-frequency inflection point (2.122 kHz) beyond audibility.

Frequency	Amplitude	Frequency	Amplitude
20	19.3	800	0.7
30	18.6	1000	0
40	17.8	1500	-1.4
50	17	2000	-2.6
60	16.1	3000	-4.8
80	14.5	4000	-6.6
100	13.1	5000	-8.2
150	10.3	6000	-9.6
200	8.2	8000	-11.9
300	5.5	10000	-13.7
400	3.8	15000	-17.2
500	2.6	20000	-19.6

Table 1. RIAA Equalization Response

Much has been written about the audibility of even minor departures from the ideal RIAA equalization and consequently high performance consumer and professional markets demand a high degree of accuracy. These pursuits have led to a preponderance of topologies in both the active equalization and passive equalization schemes as well as active/passive approaches. Recent papers have pursued the math and have provided design guides to determine the precise values for these topologies and therefore we will not repeat that work in this document.

Although there are several common circuit topologies for realizing a RIAA phono pre-amplifier, we will be confining our discussion to two topologies popular with the high performance community. These are the fully passive topology as shown in Figure 2 and the hybrid passive/active topology as shown in Figure 3.

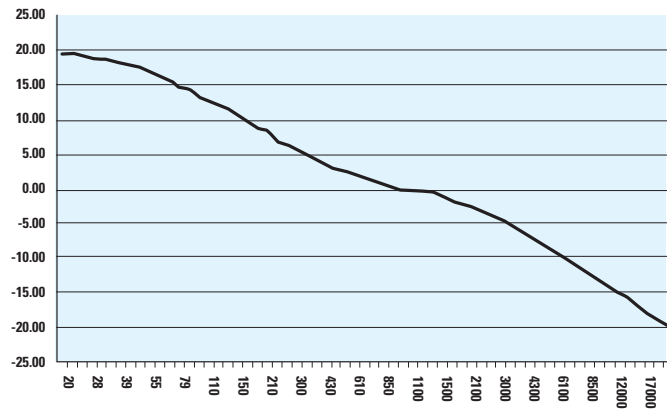

Figure 1. RIAA Equalization Response

Note that it is possible to include a very low frequency rolloff to filter out room induced and turntable mechanical contributions however given that this represents a departure from the ideal, we will not include a discussion in this paper. The reader however may incorporate this filter with the inclusion of a capacitor in the feedback leg to ground of R7.

### RIAA Phono Pre-Amplifier: Topology 1 – Passive EQ

Figure 2 shows the circuit topology for a RIAA phono pre-amplifier with passive equalization capable of interfacing with a low output moving coil cartridge.

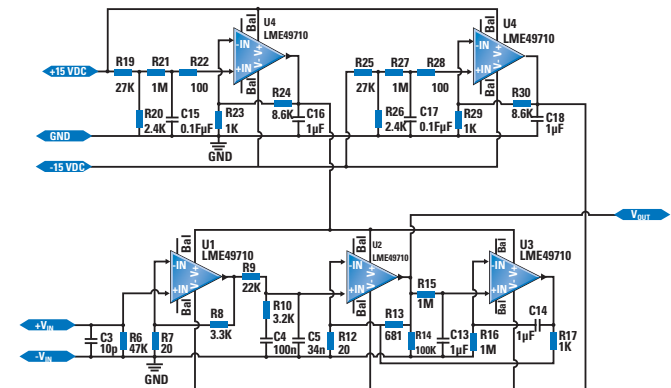

Figure 2. Passive EQ RIAA Phono Pre-Amplifier Topology

**Gain Distribution** – The gain distribution of the design is defined by two issues – noise and input overload margin. To achieve the best noise performance, it is preferable to have high gain in stage U1 with the balance in stage U2. Alternatively from an overload perspective, the opposite distribution is preferred. By using high supply voltages it is possible to extend the gain of the first stage to 44 dB and minimize overload concerns especially with lower output moving coil cartridges. (If moving magnet cartridges are being used, it may be beneficial lower the gain of the first stage by 10 to 15 dB.) In order to meet a target mid band (1 kHz) gain of approximately 55 dB, the gain of the second stage has been configured to be approximately 30 dB (44 dB + 30 dB -20 dB at midband). To completely eliminate coupling capacitors in the signal path the design is fully direct coupled. Servo amplifier U3 has been included to compensate for voltage offset errors and assure near zero voltage at the output.

**Cartridge Loading** – All cartridge suppliers provide specific resistive and capacitive loading recommendations and these should be included in the design for the specific cartridge chosen. Moving coil cartridge loading is generally in the region of  $100\Omega$  paralleled by a 100 pF capacitor, while moving magnet cartridges typically require  $47\text{ k}\Omega$  combined with a 300 pF capacitor. The schematic shown defines a  $47\text{ k}\Omega$  resistor in parallel with a 100 pF capacitor on board and therefore the builder may trim the load as specified (both resistive and capacitive) as specified by the cartridge manufacturer by soldering the needed resistor and capacitor at the input connector terminals. Generally, with moving coil cartridges, a good starting point would be  $100\Omega$  (combined with the 100 pF already on board).

**RIAA Equalization Network** – The network chosen to provide the RIAA equalization, shown graphically in *Figure 1* consist of components R9, R10, C4, and C5. The values shown are based upon the work of Lipshitz<sup>1</sup> and represent the nearest EIA standard values. Low DA and DF capacitors such as Polystyrene or polypropylene are strongly recommended. To quantify the departure from ideal, the design was both simulated with PSpice and subsequently built then measured using an inverse RIAA filter<sup>2</sup> at the input. The inverse RIAA design is described in *Reference 2*. We encourage the designer to fabricate this inverse network not only to verify simulations but also as a very convenient device to perform both objective and subjective evaluations on both this design and others as well. In this manner, signal sources other than pure phono cartridges can be used as source material.

### RIAA Phono Pre-Amplifier: Topology 2 – Active / Passive EQ

*Figure 3* shows the circuit topology for a RIAA phono pre-amplifier using a combination of both active and passive equalization capable of interfacing with a low output moving coil cartridge.

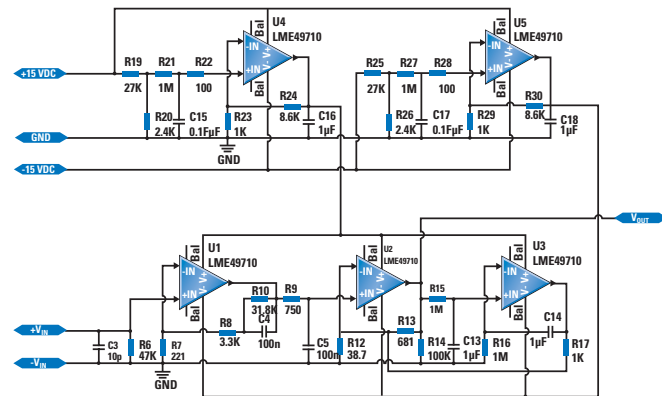

**Figure 3. Active/Positive Phono Pre-Amplifier Topology**

The first stage (U1) in combination with feedback components R8, R9, and C4 establishes the first two RIAA EQ time constants ( $3180\ \mu\text{s}$  and  $318\ \mu\text{s}$ ). This stage also provides a midband (1 kHz) gain of approximately 27 dB. Note that the DC gain of this stage is 44 dB as in the case of the fully passive topology design first stage.

The final RIAA EQ time constant ( $75\ \mu\text{s}$ ) is obtained passively between stage 1 and stage 2 from components R9 and C5. Stage 2 (U2) provides a gain of approximately 25 dB. The result is a midband gain of approximately 52 dB and a DC gain of approximately 70 dB. As with the fully passive design, U3 is included as a DC servo amplifier to guarantee near  $0\text{ V}_{\text{DC}}$  at the output.

### Electrostatic Headphone Amplifier

By a significant margin, the most common loudspeaker transducer used today is based upon electromagnetic principles. These “speaker drivers” typically take the form of a round rigid “cone” loosely suspended at its perimeter driven by a “voice coil” which surrounds a fixed magnet. The cone is driven into motion from current delivered to the voice coil. Two contradicting requirements – high cone stiffness and low assembly mass limit the performance of these designs (although planar and ribbon designs have reduced these issues in exchange for increasing costs).

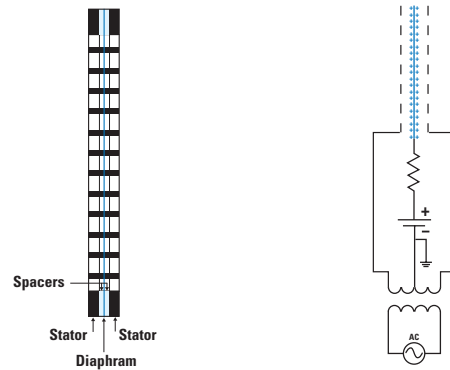

**Figure 4. Typical ESL Construction**      **Figure 5. ESL Operating Principle**

By contrast, electrostatic loudspeaker transducers (see *Figure 4*) provide a deflection force to a 3 to 5 mil suspended diaphragm (usually mylar) using electrostatic forces. The (slightly) conductive diaphragm (approximately  $10\text{ M}\Omega/\text{sq}$ ) is suspended between two acoustically transparent “stators” which themselves are driven by a high voltage out of phase audio signal (see *Figure 5*). The diaphragm is biased with a high voltage (level dependent upon relative physical distances) relative to the stators. The result is a push-pull force exerted on the diaphragm across the entire surface displaces the surrounding air. The stators are usually insulated to prevent arcing if and when the diaphragm approaches the stators. In theory, the superiority of the electrostatic transducer is due to the low mass of the diaphragm (approaching the mass of air), the application of the force across the entire surface, and the push-pull force that reduces even harmonic distortion. As a result, properly designed electrostatic transducers will provide low distortion, outstanding transient response, and wide bandwidth compared to even planar magnetic designs. This superior audible performance is not without both electrical and acoustical challenges including limited dynamic range (limited by the full excursion of the diaphragm), low frequency rolloff (due to their bi-polar room coupling), high-frequency beaming (inversely proportional to the width

of the diaphragm), and the need to provide low distortion, large voltage excursions. Headphones minimize these challenges due to their controlled acoustical environment, small size, and low output requirements. Consequently, properly designed esl headphones (along with careful attention to the driving means) are capable of the most audibly transparent audio reproduction (neglecting the loss of room special cues) available.

The electrostatic transducer used in nearly all commercial designs is a push-pull constant charge design where a diaphragm is placed within a uniform electric field. A high resistivity coating is applied to the diaphragm to provide for a constant charge across its surface. The superior linearity of this design has been described in detail previously<sup>3,4,5</sup> where it has been shown that an esl can be theoretically free of distortion when the charge on the diaphragm remains constant as it moves between the stators. Under these circumstances, the force on the diaphragm will be defined by

$$F = Q * E(t) \text{ (newtons)}$$

where  $Q = 2eAV / d$  (coulombs)

$$E(t) = v(t) / 2d \text{ (volts / meter)}$$

$$C = eA / d \text{ (farads)}$$

therefore  $F = CVv(t) / d$  (newtons)

where  $C =$  capacitance of the transducer (diaphragm to stator)

$$V = \text{Bias Voltage (volts)}$$

$$v(t) = \text{time varying signal}$$

$$d = \text{diaphragm to stator spacing (meters)}$$

$$A = \text{Diaphragm Area (sq-meters)}$$

$$e = 8.85 * 10^{-12} \text{ (farads / meter)}$$

The electrostatic transducer is primarily capacitive in nature (in contrast to the low impedance, mostly resistive-inductive, load of the electromagnetic transducer) and therefore demands a source capable of delivering suitable charging currents. Because the predominance of commercial loudspeakers are electromagnetic based, all commercial amplifiers are designed to interface with these low-impedance loads. Accordingly, all electrostatic loudspeaker manufacturers provide the needed bias voltage and voltage amplification in the form of an add-on “interface unit” typically consisting of a bias supply and step up transformer with a suitably high step up ratio (Figure 5). Unfortunately, it is difficult to design a wide band transformer with superior performance when high step-up ratios are required. A superior solution is to drive the stators directly with a large voltage swing, wide bandwidth amplifier capable of delivering the current necessary to support the capacitive load imposed by the transducer.

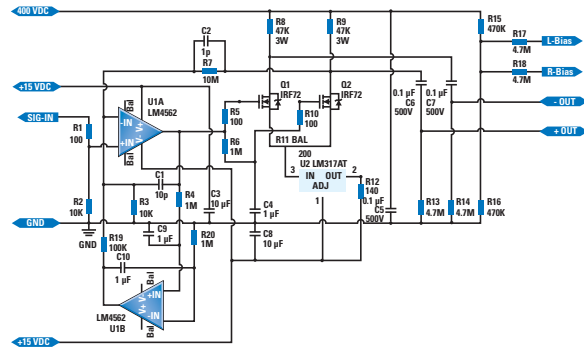

Figure 6. ESL Amplifier Schematic

The design presented in Figure 6 will deliver nearly 200 V<sub>p-p</sub> across the full audio bandwidth when interfaced to the popular Stax type 1 electrostatic headphones. A bias of 200 V<sub>DC</sub> is shown although the resistive divider can be altered to provide a bias voltage up to 400 V<sub>DC</sub>. Note that many of the Stax type 1 headphones have similar drive and bias requirements making this design suitable for these models as well.

From Figure 5 it is clear that a balanced high-voltage drive is needed. In this design, one half of the LM4562 is used to drive to a discrete differential amplifier using a pair of high voltage N-Channel MOSFETs. An LM317 is used in a current source mode to insure that the CMRR remains above 60 dB. The second half of the LM4562 is used as a servo amplifier. This servo actively compensates for the fully DC feedback via R7 to insure that the output of U1A will remain at 0 V<sub>DC</sub> needed to keep the differential amplifier Q1 and Q2 properly biased for maximum V<sub>OUT</sub>. Potentiometer R11 allows for variation in MOSFETs and must be adjusted to have 0 V<sub>DC</sub> difference across Q1 and Q2 drain terminals. For best performance regulated sources should be used for the 400 V<sub>DC</sub> and dual 15 V<sub>DC</sub> supplies.

The design is fully DC-coupled from input to the output but for the output coupling capacitors. Using the highest quality capacitors (polypropylene, polystyrene or Teflon) will result in the highest audible performance.

It should be noted that several alternate designs were built and auditioned including fully differential topologies however the most musical audible performance was achieved using the topology shown.

Note that is it possible to directly substitute a 6FQ7/6CG7 miniature triode or 6SN7 octal triode in place of the MOSFETs if a tube output stage is desired. In this case, a suitable filament supply will be required. ■

For more information, visit  
[audio.national.com](http://audio.national.com)

1. Lipshitz, S.J., "On RIAA Equalization Networks," JAES Vol 27, No 6, June 1979, pp 458 – 481
2. Lipshitz, Stanley and Jung, Walt, "A High Accuracy Inverse RIAA Network," The Audio Amateur, 1/ 1980
3. Vogt, Hans, "Recent Developments in the Design of Electrostatic Loudspeakers," Radio News, 13, 656 (1932)
4. Walker, P.J., "Wide range Electrostatic Loudspeakers," Wireless World, 41, 20S (1955)
5. Janzen, A.A., Pritchard, R.L., and Hunt, F.V., Electrostatic Loudspeakers, (Office Naval Research NR-014-903, T.M. 17), Cambridge: Harvard University (Acoustics research Laboratory), 1950

**National Semiconductor**  
2900 Semiconductor Drive  
Santa Clara, CA 95051  
1 800 272 9959

**Mailing Address:**  
PO Box 58090  
Santa Clara, CA 95052



## Analog Edge AN 1651 Figures

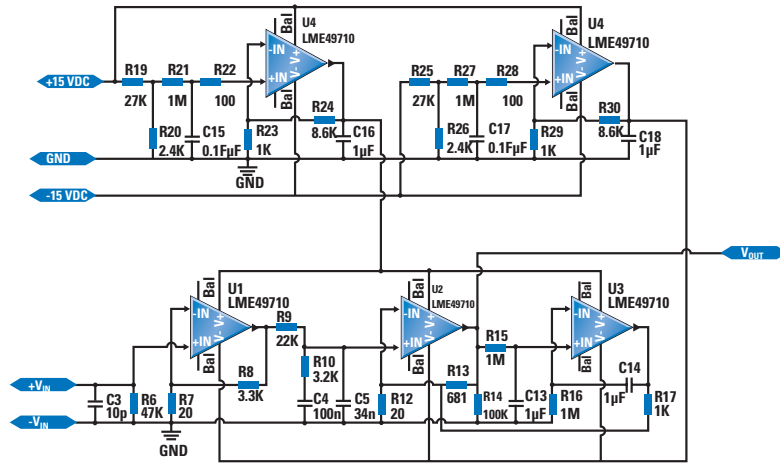

Figure 2. Passive EQ RIAA Phono Pre-Amplifier Topology

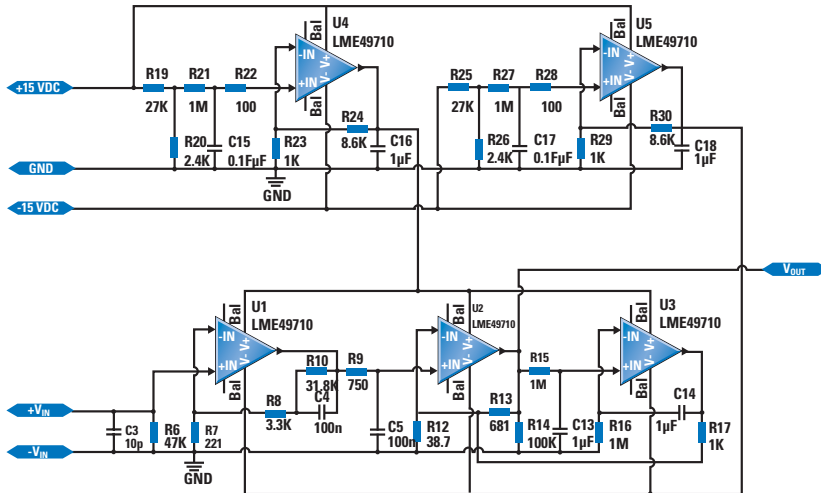

Figure 3. Active/Positive Phono Pre-Amplifier Topology

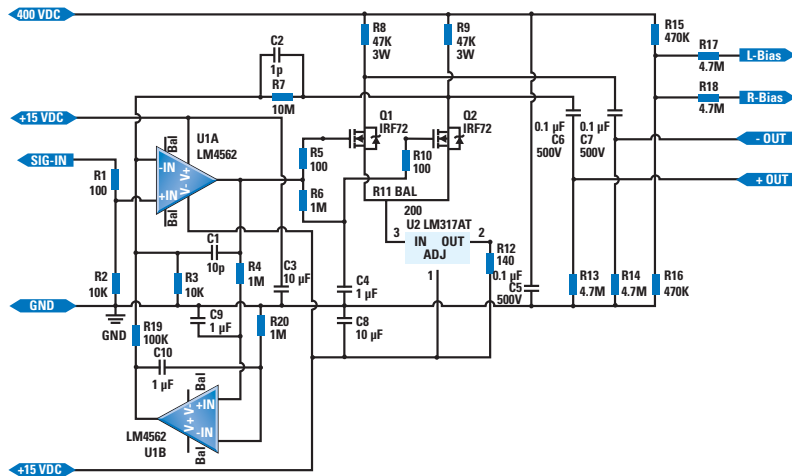

Figure 6. ESL Amplifier Schematic