

The constant on-time (COT) control method used by the LM3402 and LM3404 constant-current buck regulators provides a balance between control over switching frequency and fast transient response. Normally this “quasi-hysteretic” control senses the input voltage and adjusts the on-time  $t_{ON}$  of the power MOSFET as needed to keep  $f_{SW}$  constant. Investigating a little more deeply reveals that  $t_{ON}$  is in fact proportional to the current flowing into the  $R_{ON}$  pin. The addition of a single, general-purpose PNP transistor forces  $t_{ON}$  to be proportional to  $(V_{IN} - V_O)$  and provides two benefits that are particularly useful to LED drivers: improved tolerance of the average LED current,  $I_F$ , and constant LED ripple current,  $\Delta I_F$ .

### Benefits of Constant Ripple

The luminous flux and dominant wavelength (or color temperature for white LEDs) of LED light are controlled by average current. The constant-ripple LED driver in *Figure 1* is much better at controlling average LED current over changes in both input voltage and changes in output voltage because it fixes the valley of the inductor current and also fixes the current ripple.

Controlling LED ripple current implies control over peak LED current, which in turn affects the luminous flux of an LED. All LEDs have a relationship between their

luminous flux and forward current,  $I_F$ , that is linear up to a point. Beyond that point, increasing  $I_F$  causes more heat than light. High ripple current forces the LED to spend half of the time at a high peak current, putting it in the lower  $lm/W$  region of the flux curve. This reduces the light output when compared to a purely DC drive current even though the average forward current remains the same.

Close inspection of LED datasheets also reveals that the absolute maximum ratings for peak current are close to or often equal to the ratings for average current. High current density in the LED junction lowers lumen maintenance, providing yet another incentive for keeping the ripple current under control.

### Circuit Performance

The circuit of *Figure 1* uses the PNP-based constant ripple concept to take an input voltage of 24VDC  $\pm 10\%$  and drive 1A through as many LEDs in series as the maximum output voltage will allow. For a circuit with ‘n’ LEDs of forward voltage  $V_F$  in series, the output voltage is:

$$V_O = 0.2 + n \times V_F$$

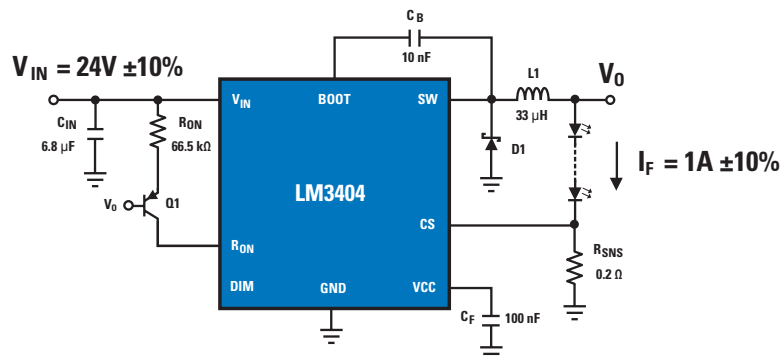

Figure 1. Constant Ripple LED Driver Using the LM3404 Buck Regulator

The maximum voltage that can be achieved is then:

$$V_{O-MAX} = V_{IN-MIN} \times (1 - f_{SW} \times 300 \text{ ns})$$

In the above equation, the 300 ns term reflects the minimum off-time of the LM3402 and LM3404 buck regulators.

### Making a “Universal” Current Source

Figure 2 and Figure 3 show the dependence of ripple current and switching frequency against output voltage. This change in output voltage is effectively a change in the number of series-connected LEDs that the circuit drives.

One circuit with both average current and ripple current controlled independently of  $V_O$  can now power anything from a single infrared LED ( $V_{F-TYP}$  of ~1.8V) to as many as five white LEDs in series, yielding a  $V_O$  of ~18V. Such a circuit would be ideal for an LED-driving power-supply module. Many of the existing, commercial AC-input ‘brick’ modules for driving LEDs are specified to provide a constant current of ‘x’ mA at a voltage up to ‘y’ volts. Depending on the need for galvanic isolation and/or power factor correction, the LM3402 or LM3404 buck regulator could be paired with an existing AC-DC regulator to provide the 24V, resulting in a high-quality universal current source.

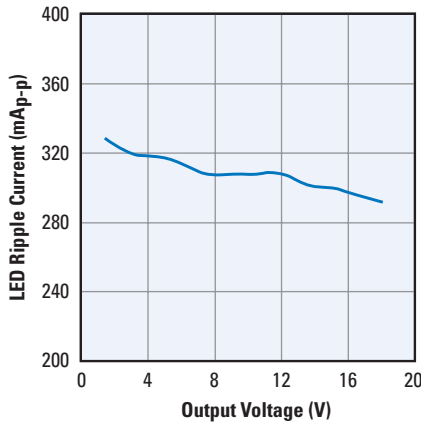

Figure 2. Ripple Current vs. Output Voltage

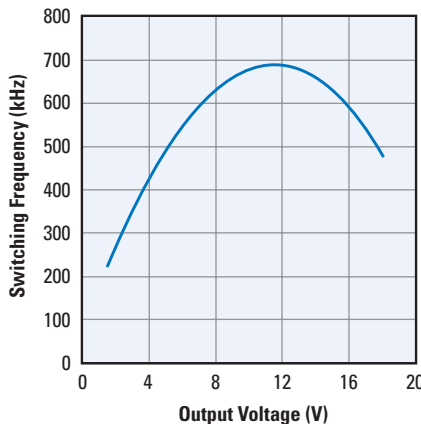

Figure 3. Switching Frequency vs. Output Voltage

### Design Procedure

Designing for constant ripple in a COT converter requires a change in the selection of the on-time setting resistor  $R_{ON}$ :

1. Start with the typical input voltage,  $V_{IN-TYP}$ , and an output voltage that is at the center between the minimum and maximum expected value,  $V_{O-CTR}$ . Use the maximum permissible switching frequency,  $f_{SW-MAX}$ , and the desired peak-to-peak inductor ripple current,  $\Delta i_L$ . The required inductance is then:

$$L = \frac{(V_{IN-TYP} - V_{O-CTR}) \times V_{O-CTR}}{V_{IN-TYP} \times f_{SW-MAX} \times \Delta i_L}$$

2. Select the closest standard inductor value to  $L$  and call it  $L_{STD}$ .  $R_{ON}$  can then be calculated with the following expression:

$$R_{ON} = \frac{\Delta i_L \times L_{STD}}{1.34 \times 10^{-10}}$$

3. Use the closest 1% resistor value for  $R_{ON}$ .
4. Design for the remaining components (input capacitor, Schottky diode, etc.) remains the same, and is outlined in the LM3402 and LM3404 datasheets.

### Switching Frequency Changes

When using the LM3402 and LM3404 buck regulators in the constant-ripple configuration, the switching frequency will change with  $V_{IN}$  and  $V_O$ . Careful attention to PCB layout and proper filtering must be employed in all switching converters, and particular care is needed for systems where  $f_{SW}$  changes. The following steps can be used to predict the switching frequency:

1. Calculate the on-time at the minimum and maximum values of  $V_{IN}$  and  $V_O$  using the actual 1% resistor value of  $R_{ON}$  and the following equation:

$$t_{ON} = \frac{0.134 \times R_{ON}}{V_{IN} - V_O + 0.6}$$

2. The switching frequency can then be determined using  $t_{ON}$  and the following expression:

$$f_{SW} = \frac{V_O}{V_{IN} \times t_{ON}}$$

### Conclusion

A pure DC LED drive current would be ideal for LEDs, but in practice the majority of LED lighting is powered from the AC mains and includes at least one switching regulator between the wall and the LEDs. Even battery or solar-powered systems are likely to employ a switching regulator in the interest of power efficiency. Therefore, some amount of ripple current will be present in almost every LED driver design. Allowing higher ripple current reduces the size and cost of the drive circuit, but comes at the expense of light output and reliability. Armed with the ability to control both LED ripple current and switching frequency, the LED lighting designer can make his/her own trade-offs between solution size, cost, and quality based on the needs of the application. ■

## BOM

| ID               | Part Number       | Type           | Size             | Parameters                    | Qty | Vendor       |
|------------------|-------------------|----------------|------------------|-------------------------------|-----|--------------|
| U1               | LM3404            | LED Driver     | SO-8             | 42V, 1.2A                     | 1   | NSC          |
| Q1               | CMPT3906          | PNP            | SOT23-6          | 40 V <sub>CE</sub> , 10 mA    | 1   | Central Semi |
| L1               | VLF10040T-330M2R1 | Inductor       | 10 x 10 x 4.0 mm | 33 $\mu$ H, 2.1A, 80 $\Omega$ | 1   | TDK          |
| D1               | CMSH2-40M         | Schottky Diode | SMA              | 40V, 2A                       | 1   | Central Semi |
| C <sub>F</sub>   | VJ0603Y104KXXAT   | Capacitor      | 0603             | 100 nF, 10%                   | 1   | Vishay       |
| C <sub>B</sub>   | VJ0603Y103KXXAT   | Capacitor      | 0603             | 10 nF, 10%                    | 1   | Vishay       |
| C <sub>IN</sub>  | C4532X7R1H685M    | Capacitor      | 1812             | 6.8 $\mu$ F, 50V              | 1   | TDK          |
| R <sub>SNS</sub> | ERJ8RQFR20V       | Resistor       | 1206             | 0.2 $\Omega$ , 1%             | 1   | Panasonic    |
| R <sub>ON</sub>  | CRCW06035762F     | Resistor       | 0603             | 57.6 k $\Omega$ , 1%          | 1   | Vishay       |

**National Semiconductor**  
2900 Semiconductor Drive  
Santa Clara, CA 95051  
1 800 272 9959

**Mailing Address:**  
PO Box 58090  
Santa Clara, CA 95052



To learn more about LED drivers, visit:  
[national.com/LED](http://national.com/LED)