

Portable battery sources are constantly challenged by the handheld applications' increasing functionality and power demands. By better understanding the applications' energy consumption, designers can produce energy-efficient solutions that will conserve battery life and provide a better end-user experience.

Conserving Energy in Portable Displays

Display backlighting presents a significant energy challenge as handheld displays increase in size, resolution, and brightness. A typical small display module can require between three to ten LEDs for proper illumination.

To address the backlit display's energy consumption, one power-efficient method to drive LEDs is the switched capacitor. This technique connects the input voltage to a multiple-gain switched capacitor that produces a regulated output. The output voltage equals the gain multiplied by the input voltage during open loop operation. Closed loop operation enables a fixed output that should be slightly higher than the LED forward voltage and any voltage drop. The difference between output voltage and forward voltage is the headroom that needs to be monitored to ensure current flow. The switched capacitor remains in the most efficient gain over the widest input voltage consuming the least amount of energy through gain transitions that maintain regulation based on LED forward voltage and load requirements. Dual gain boost modes (1x and 3/2x for the LM2755 and LM2756; 2x and 3/2x for the LM2757) allow for the highest possible efficiency over a wide input voltage range resulting in longer battery life.

Consumer trends continue to dictate smaller portable devices, making PCB area much more valuable. The switched capacitor topology offers an added benefit as an inductor-less solution that saves on solution size and bill of materials. The LM2755, LM2756, and LM2757 are examples of switched capacitor boost technology that drive up to 10 LEDs (each driving up to 30 mA of diode current). This smaller solution provides the ability to place the driver in a local area, versus a central area, which reduces EMI.

Programmability of white LEDs is important to control display illumination. For example, when an end-user is having a conversation on a mobile phone, they are no longer interacting with the display, and the display has

the option to dim. Both the LM2755 and LM2756 include an I²C-compatible interface that controls the display illumination based on handset operation.

Figure 1 shows the 32 exponential dimming step settings with an 800:1 dimming ratio which enables true perceived linear brightness level control and a dimming profile that leads to a smooth on/off display transition. The human eye is a logarithmic detector as it responds to light in terms of equal ratios rather than equal increments. What is recognized to be the linear augmentation of brightness is in reality exponential. By allowing the backlight to be dimmed or turned off, the designer gains flexibility and the ability to save battery life.

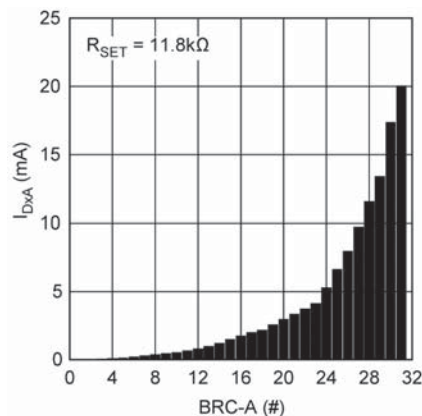

Figure 1. 32 Exponential Brightness Levels

Figure 2 is a typical application circuit of the LM2756. The LM2756 drives 8 LEDs separated in three independently controlled groups for multiple display purposes. The following equation configures the LED current levels:

$$I_{DxA/B/C(A)} = 189 \times (V_{ISET} / R_{SET})$$

With a properly selected resistor (R_{SET}) placed between I_{SET} and GND, the desired level of current can be passed through the LEDs connected to DxA and DxB , where x is a number referring to the particular LED current sink and A, B, and C refers to the particular group of LEDs.

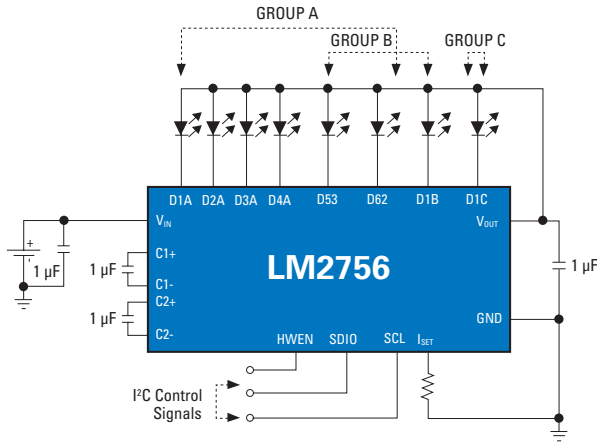

Figure 2. LM2756 Typical Application Circuit

Once the current level is set, analog current scaling internally dims the LEDs using the I²C-compatible interface. The 32 exponential analog brightness levels shown in *Figure 1* can be configured for the LEDs in Group A, while LEDs in Group B and Group C can handle 8 linear analog brightness levels.

With the ability to separately control several groups of LEDs, a single LED driver can control a main display, a secondary sub-display or keypad LEDs, and an indicator LED. The LM2756 integrates these features by incorporating eight current sinks and dividing them into three groups. Four current sinks are comprised in Group A, while Group B and Group C have one current sink each. By manipulating a register, two extra sinks (D53 and D62) are available for either Group A or Group B. This allows 4, 5, or 6 LEDs to be used for the main display, leaving extra LEDs for additional lighting features.

Peripheral Lighting

Personal mobile devices have greater illumination needs than just the main display. Supplemental LEDs are required for further lighting functions consuming more battery energy. Keypad lighting is an important characteristic of handheld applications that does not require as much LED current matching as current-sourced main display backlighting drivers. The LM2757 provides the smallest switched capacitor, voltage-sourced, boost solution to illuminate keypad LEDs with up to 90% efficiency. Indicator LEDs alert end-users of low battery, battery charging activity, and incoming messages. These LEDs can also be used in fun-lighting applications. With three independent RGB LED outputs, the LM2755 permits programmable blinking patterns, via I²C-compatible interface, for each output enabling multiple zone lighting.

For indicator and cosmetic lighting purposes, LEDs usually require a generated pattern. The LM2755, shown in *Figure 3*, allows the designer to program a trapezoidal dimming waveform to independently control each output. The following equations calculate the durations of the delay, rise, fall, high, and low times shown on the waveform in *Figure 4*:

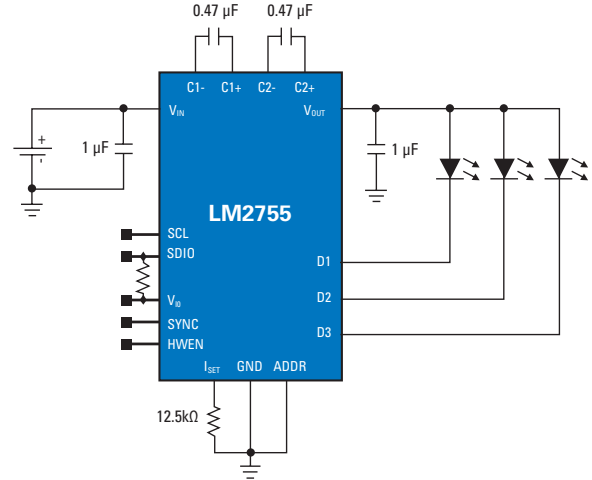

Figure 3. LM2755 Typical Application Circuit

$T_{STEP} = 50\mu s \times 2^{(N+1)}$ if using the internal clock
 or $T_{STEP} = (1/f_{PWM}) \times 2^{(N+1)}$ if using the external clock on the SYNC pin

$$t_{rise/fall\ Total} = T_{STEP} \times (n_{high} - n_{low}) \times n_{Trise/fall},$$

where $0 \leq n_{Trise/fall} \leq 255$

$$t_{rise\ or\ fall\ Total} = 50\mu s \times (n_{high} - n_{low}),$$

where $n_{Trise/fall} = 0$

$$t_{high\ or\ low} = T_{STEP} \times (n_{high/low} + 1),$$

where $0 \leq n_{Thigh/low} \leq 255$

$$t_{delay} = T_{STEP} \times n_{delay},$$

where $0 \leq n_{delay} \leq 255$

The variables n_{Trise} , n_{Tfall} , n_{Thigh} , and n_{Tlow} are numbers between 0 and 255 while n_{high} and n_{low} are selected numbers between 0 and 31 that become the brightness level boundaries when the dimming waveform enable bits are set to '1'. N is a number from 0 to 7 that is stored in the Time Step register. The PWM modulating signal period, f_{PWM} , is set to a default value of 50 μs . If using an external clock, this signal period becomes: $f_{PWM} = f_{SYNC}/32$. The custom waveforms only need to be programmed once for each output. After the values have been set, the I²C-compatible interface toggles start and stop times for the lighting pattern. Timing control features, like the one found in the LM2755, are an ideal tool for any peripheral lighting needs.

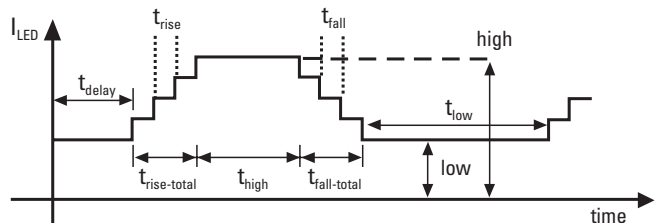

Figure 4. LM2755 LED Timing Control

Enabling New Display Technologies

Efficient power conversion for white LEDs provides diminishing returns. Designing towards organic LED (OLED) displays can solve a designer's energy problems. Normal LCD displays rely on white LED backlighting, while OLED displays rely on each pixel to directly produce light, making colors more vibrant. OLED displays conserve more energy by illuminating the display without a backlight. To do this, every pixel is turned on and off as needed by circuitry controlling each column of pixels. A pixel can contain one diode for monochromatic displays, or three diodes (red, green, and blue) for full-color displays. Unlike LCD display modules, the diodes are embedded within the OLED display module. In the case of Passive Matrix OLED (PMOLED) displays, the power supply is used to pre-charge an entire row of pixels, usually with voltages beyond the normal 5V. The amount of voltage applied depends on the number of pixels in each row or the size of the OLED display panel.

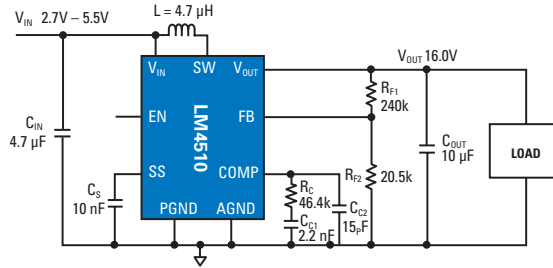

Figure 5. LM4510 Typical Application Circuit

Figure 5 shows the LM4510 OLED driver which offers currents between 80 mA and 280 mA, and voltages between 5V and 18V from a Li-Ion battery input. This switching regulator provides a small energy efficient solution by maximizing power efficiency up to 85% and eliminating an external Schottky diode. Smart solutions like the LM4510 pave the way for next generation technologies in portable media devices.

Consumers continue to demand greater media-centric functionality from their portable handheld devices, including high-quality video, audio and other media-rich features, without sacrificing size or battery life. To meet this challenge, designers must develop innovative solutions that conserve energy and deliver the cutting-edge performance and design consumers have grown to expect from their portable handheld devices.

National Semiconductor
2900 Semiconductor Drive
Santa Clara, CA 95051
1 800 272 9959

Mailing Address:
PO Box 58090
Santa Clara, CA 95052

 **National
Semiconductor**
The Sight & Sound of Information