

Application Note AN-1719

Fully Differential Feedback Amplifiers (FDA) such as National's LMH6550, LMH6551, and LMH6552 are used to provide balanced low-distortion amplification and level shifting to wide bandwidth differential signals. A simplified conceptual diagram of an FDA is shown in *Figure 1* where two forward paths amplify the two complementary halves of the differential signal. A separate common mode feedback circuit controlled by the V_{CM} control input sets the output common mode voltage independent of the input common mode, as well as forcing the O_N and O_P outputs to be equal in magnitude and opposite in phase.

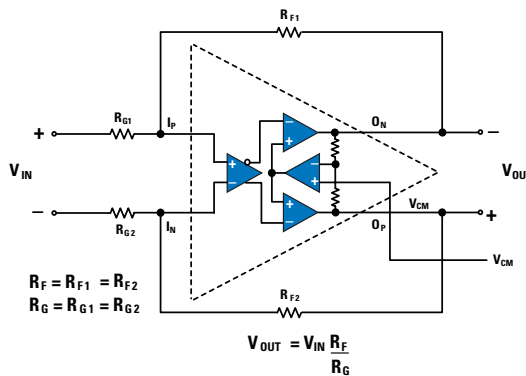

Figure 1: Simplified Conceptual Diagram of Fully Differential Amplifier

The LMH6552 is a 1.5 GHz device which allows operation at gains greater than unity with exceptional gain flatness without sacrificing bandwidth. With 450 MHz of 0.1 dB unity gain flatness the device is ideally suited to driving a range of 8- to 14-bit high-speed ADCs.

In designing an FDA to drive an ADC it is required to ensure that the FDA does not degrade the ADC's Signal-to-Noise and Distortion (SINAD) performance. A key element of this analysis is determining and optimizing the noise performance of the FDA. Voltage Feedback (VFB) FDAs have historically been constrained to operating at low gain due to their poor noise performance at higher gains. The LMH6552 CFB architecture overcomes this constraint, delivering a noise advantage as well as a gain bandwidth advantage over alternative VFB devices.

Output Noise Calculation for Fully Differential Amplifiers

A general purpose FDA noise model is shown in *Figure 2*. I_{NP} and I_{NM} are the input-referred noise currents for the FDA's positive and negative input terminals respectively,

Mike Ewer, Application Engineer
Robert Malone, Design Engineer

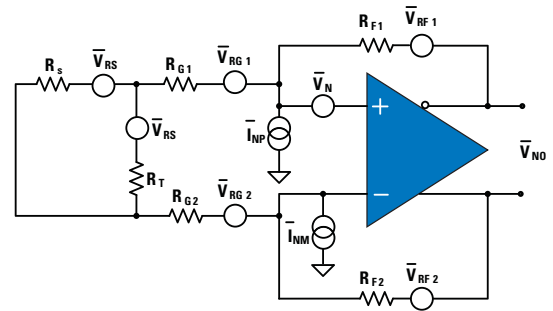

Figure 2: Fully Differential Amplifier Noise Model

and V_N is its input referred noise voltage. Included in the model are noise sources associated with resistive elements in the feedback and source termination networks.

The total output referred noise density V_{NO} in nV/\sqrt{Hz} , is calculated by taking the root square sum (rss) of the output referred noise from each source in the model. Separate the equation for V_{NO} into two components; the first being due to the input referred noise from the FDA, V_{NOFDA} , and the second due to thermal noise from the resistive feedback network, V_{NOFB} .

$$V_{NO} = \sqrt{V_{NOFDA}^2 + V_{NOFB}^2}$$

CMRR and balance error are key. The differential feedback network is balanced by selecting $R_{F1} = R_{F2} = R_F$ and $R_{G1} = R_{G2} = R_G$, so both positive and negative feedback factors are matched and symmetric. Replacing R_S and R_T with their Thevenin equivalent source resistance, $R_{STH} = R_S || R_P$, the FDA and feedback network output noise densities are:

Equation 1

$$V_{NOFDA}^2 = V_N^2 \left(\frac{R_F + R_{GE}}{R_{GE}} \right)^2 + I_{NP}^2 R_F^2 + I_{NM}^2 R_F^2$$

Equation 2

$$\overline{V_{N_{out}}}^2 = 4kT(2R_F) + 4kT(2R_G) \left(\frac{R_F}{R_{G_{eq}}} \right)^2 + 4kTR_S (R_{S_{in}}) \left(\frac{R_F}{R_{G_{eq}}} \right)^2$$

$$R_{G_{eq}} = R_G + \frac{R_S \parallel R_T}{2}$$

The impact of external resistor noise is determined by the differential feedback topology (*Equation 2*), regardless of whether a CFB or VFB FDA is chosen. However, the influence of the FDA on total output noise density (*Equation 1*) can largely be influenced by the choice of FDA architecture.

In a VFB FDA, the differential input impedance is very high (usually hundreds of KΩ to several MΩ), and noise sources internal to the FDA will tend to refer to the input as voltages. Consequently, input referred noise currents will be quite small, on the order of a few pA/√Hz, and will only contribute a significant portion of the total output noise when RF is large, which is usually not the case. Note that the gain term for V_N in *Equation 1* is simply the reciprocal of the equivalent feedback factor β_{EQ} , which is related to the differential amplifier's closed loop gain G by:

$$G = \frac{R_F}{R_{G_{eq}}} = \frac{1}{\beta_{EQ}} - 1$$

In other words, operating a VFB FDA at high values of gain is necessarily accompanied by a proportional increase in output noise density, and can lead to degradation of overall noise performance when the FDA is a significant source of noise in a system.

A very different result arises when a CFB FDA, such as the LMH6552, is considered. Here the differential input stage is essentially a current controlled current source, with ideally zero differential-input impedance. As a consequence, noise sources internal to the amplifier tend to refer to the inputs as currents, rather than as voltages, and the total FDA output noise will be dominated by the sum of input noise currents I_{NP} and I_{NM} multiplied by the feedback resistor squared.

Unlike a VFB FDA, the output noise of a CFB FDA depends on the value of R_F rather than on the amplifier's gain. Hence, increasing the gain by reducing R_G does not appreciably degrade the noise performance of the circuit. This is an extremely important result and highlights one of the

key advantages of using a CFB FDA over a VFB FDA in differential signaling applications.

Noise Figure Calculation for Fully Differential Amplifiers

Noise performance is often described in terms of the system noise figure, which is 10 log of the signal-to-noise ratio at the system's input, divided by the signal to noise ratio at its output. Noise figure is a quantitative measure of how much noise is added to a given signal as it propagates through a processing chain. For amplifiers it can be conveniently expressed as the ratio of output noise density to source noise density by the following equation.

The product GD_T is the voltage gain of the amplifier from V_S to V_O including the signal attenuation of the input termination network.

To highlight the difference in noise performance between CFB and VFB FDAs, the application circuit of *Figure 3* is used to calculate the output noise spectral density and noise figure at various values of gain using both the LMH6552 (CFB) and LMH6550 (VFB) FDAs in a 100Ω system. R_F is held at 301Ω and the termination resistor R_T is adjusted at each value of gain to maintain a 100Ω differentially terminated input. The results are presented graphically in *Figure 3*.

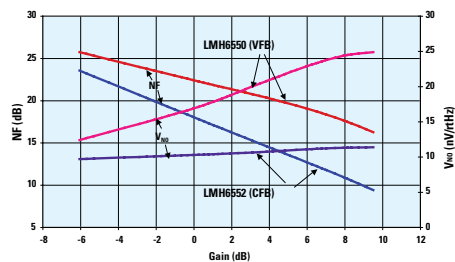

Figure 3: Noise Figure and Voltage Noise Spectral Density vs Gain

Conclusion

The choice between a current or voltage mode FDA may depend on many factors and will ultimately come down to which amplifier works better within a given system specification. Where low-noise, wide-bandwidth applications require the FDA to be configured for larger than unity gain CFB FDAs can offer an elegant solution.

For Additional Design Information

edge.national.com

National Semiconductor
2900 Semiconductor Drive
Santa Clara, CA 95051
1 800 272 9959

Mailing Address:
PO Box 58090
Santa Clara, CA 95052

 National Semiconductor
The Sight & Sound of Information