

Ceramic Leadless Chip Carrier (LCC)

20 Lead Ceramic Leadless Chip Carrier, Type C
NS Package Number E20A

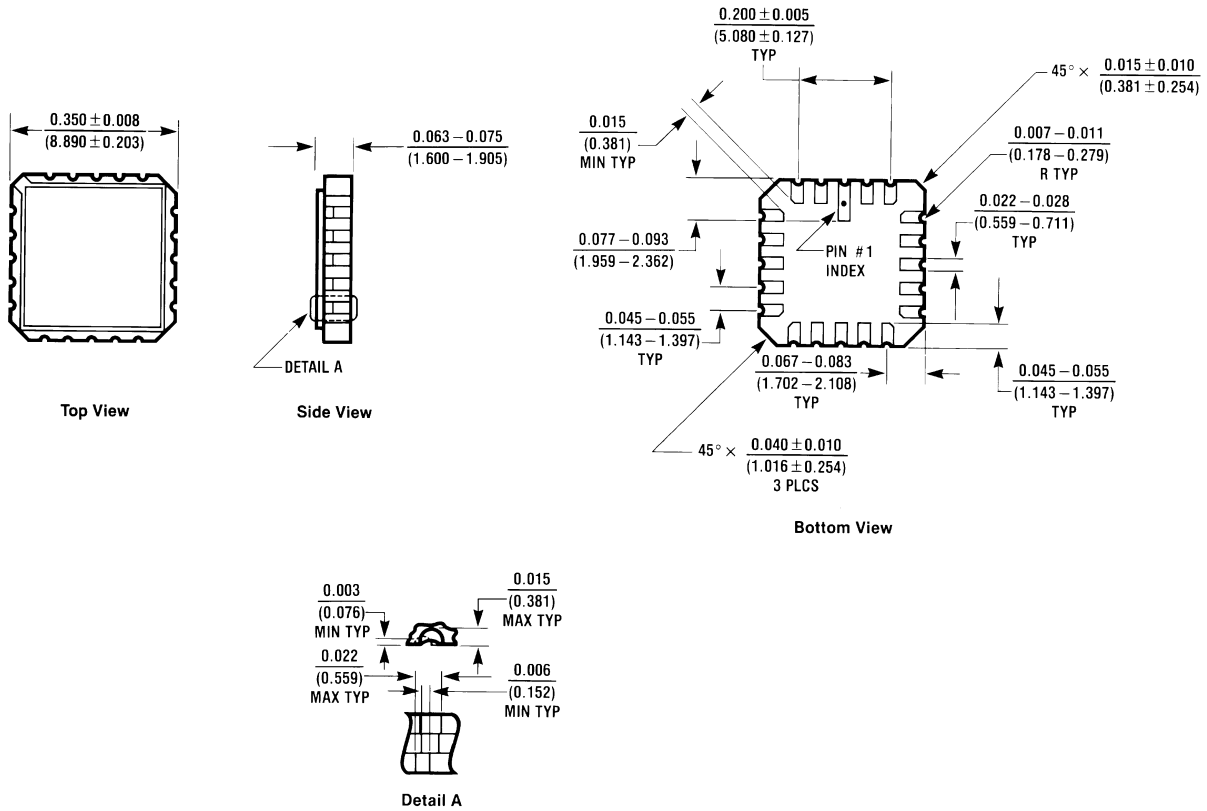

E20A (REV D)

20 Lead Ceramic Leadless Chip Carrier NS Package Number EA20B

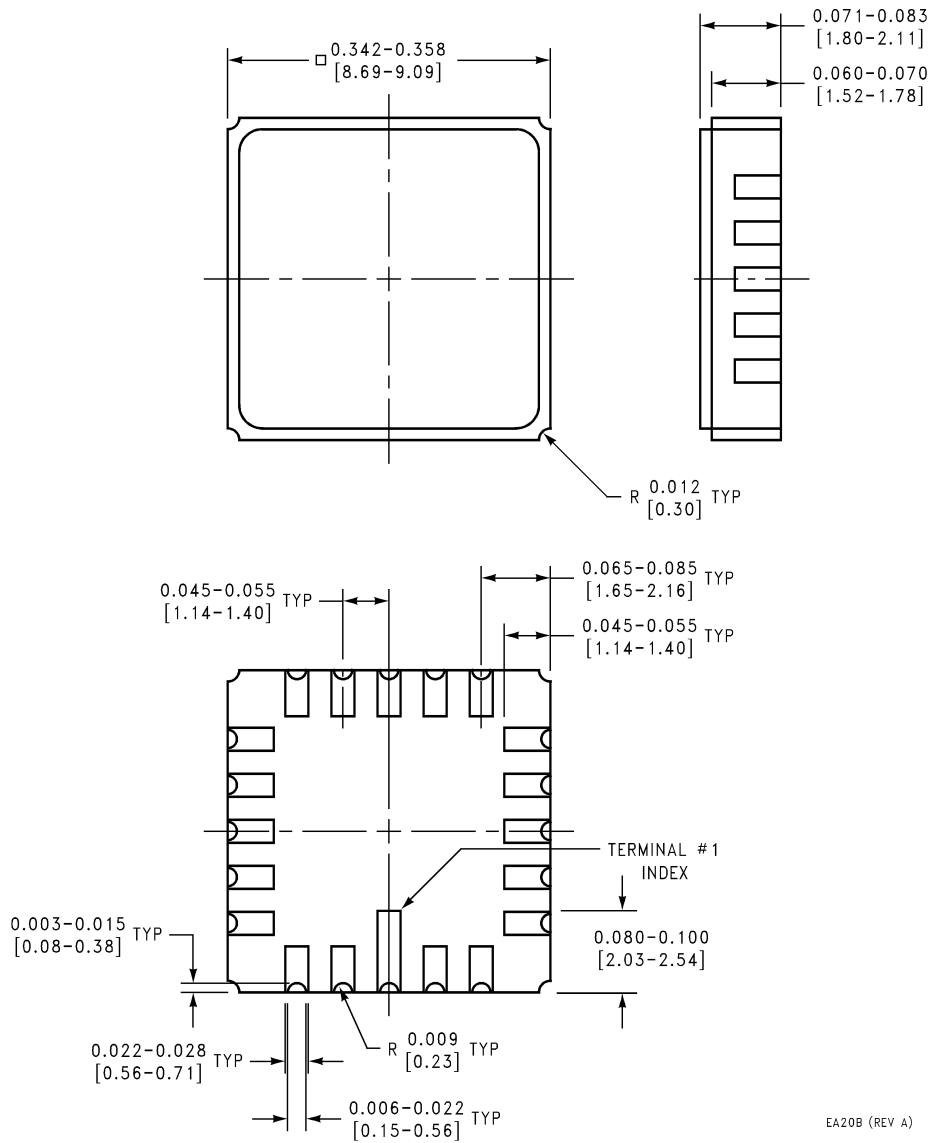

EA20B (REV A)

28 Lead Ceramic Leadless Chip Carrier, Dual Cavity NS Package Number EA028C

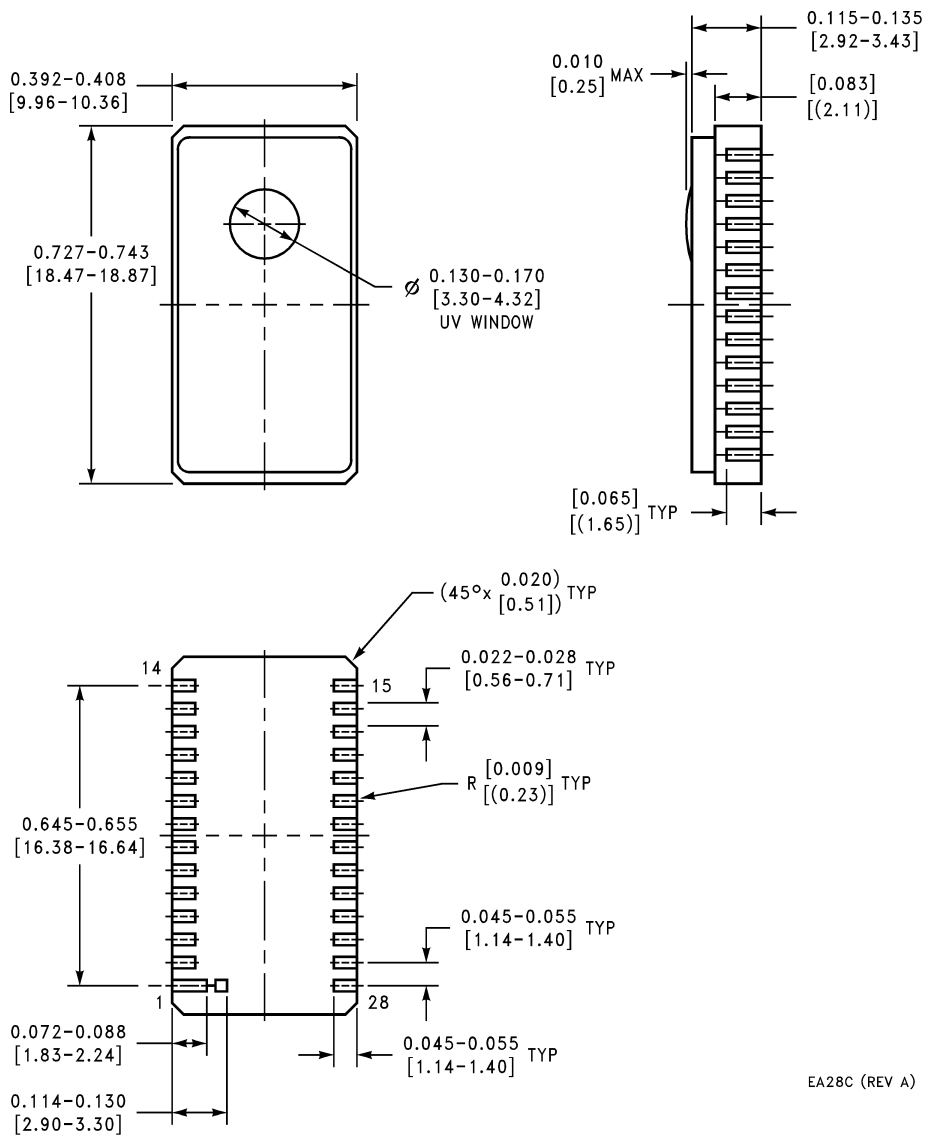

EA28C (REV A)

32 Lead Ceramic Leadless Chip Carrier, Type C NS Package Number E32C

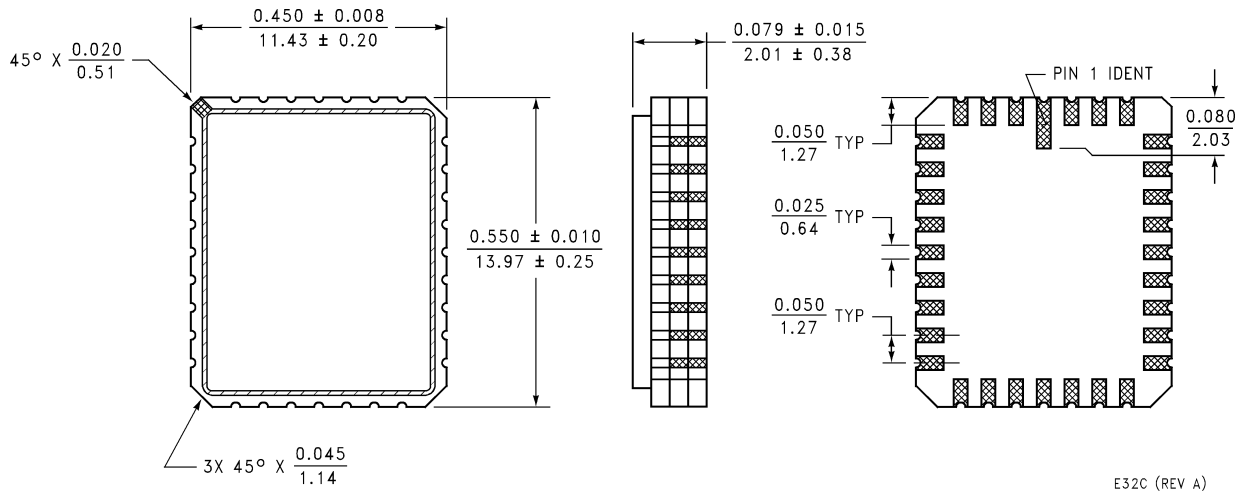

32 Lead Ceramic Leadless Chip Carrier, Type E NS Package Number EA32B

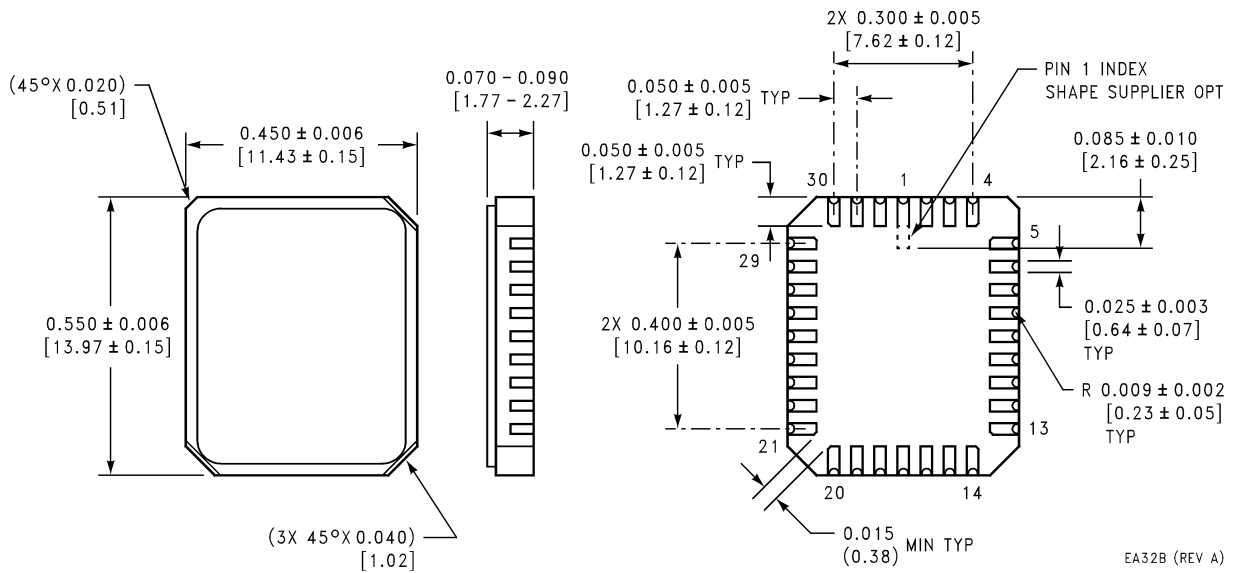

44 Lead Ceramic Leadless Chip Carrier, Type C NS Package Number E44A

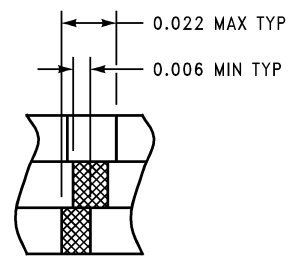
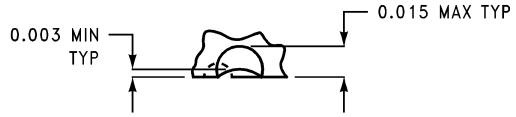
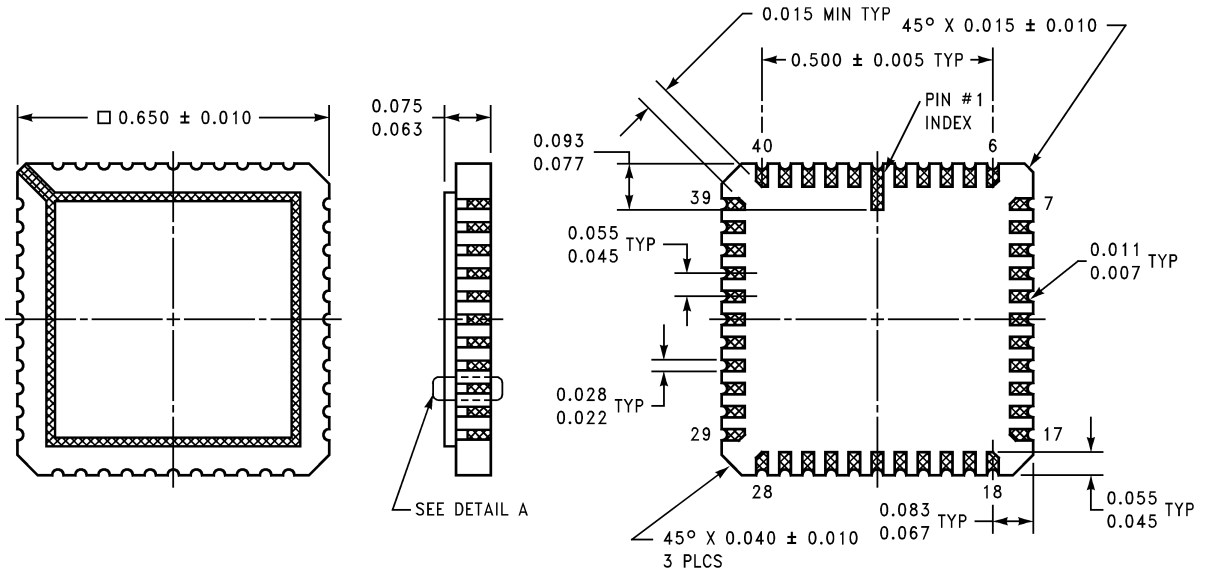

DETAIL A

E44A (REV E)

48 Lead Ceramic Leadless Chip Carrier NS Package Number EA48B

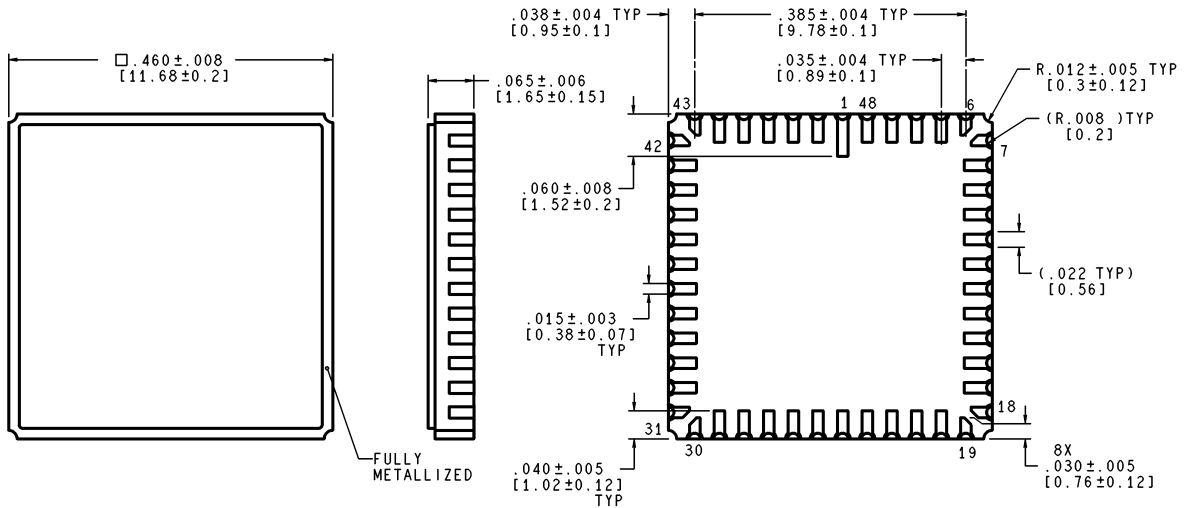

CONTROLLING DIMENSION IS INCH
VALUES IN [] ARE MILLIMETERS

EA48B (Rev A)

68 Lead Ceramic Leadless Chip Carrier, Type B NS Package Number E68B

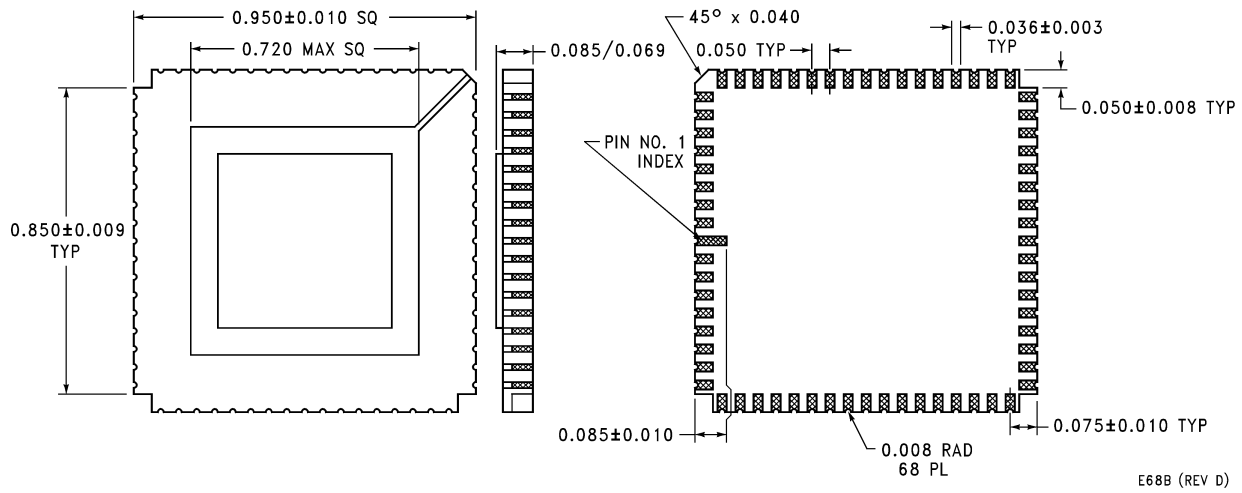

68 Lead Ceramic Leadless Chip Carrier, Type C NS Package Number E68C

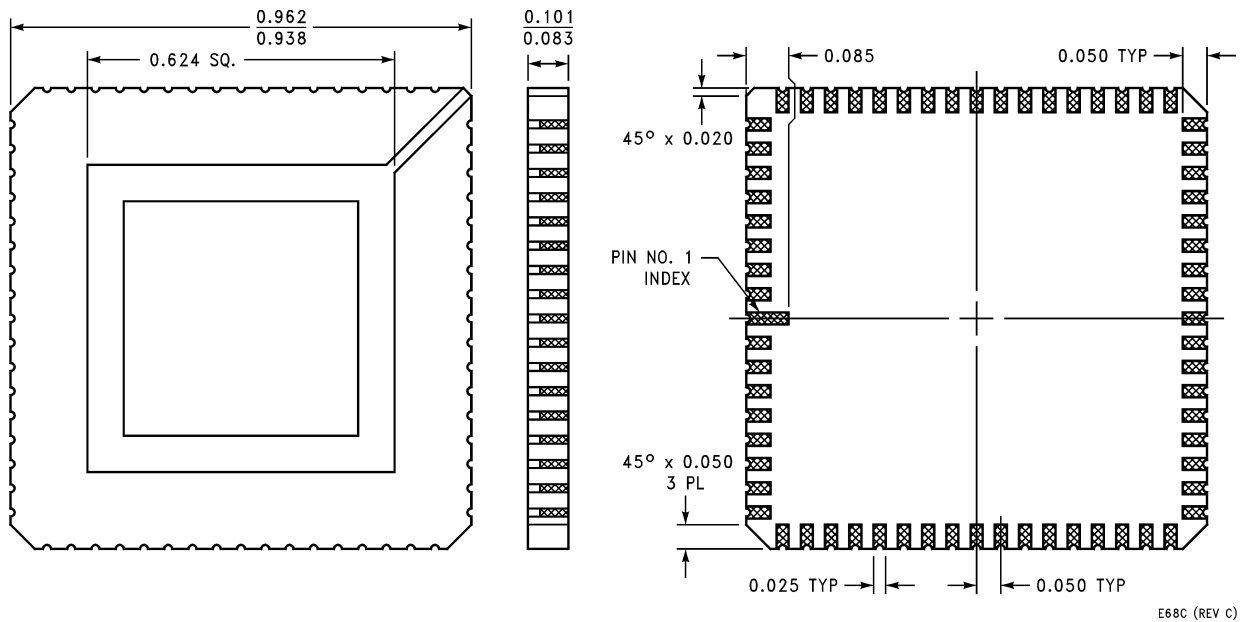

84 Lead Ceramic Leadless Chip Carrier, Type C NS Package Number E84A

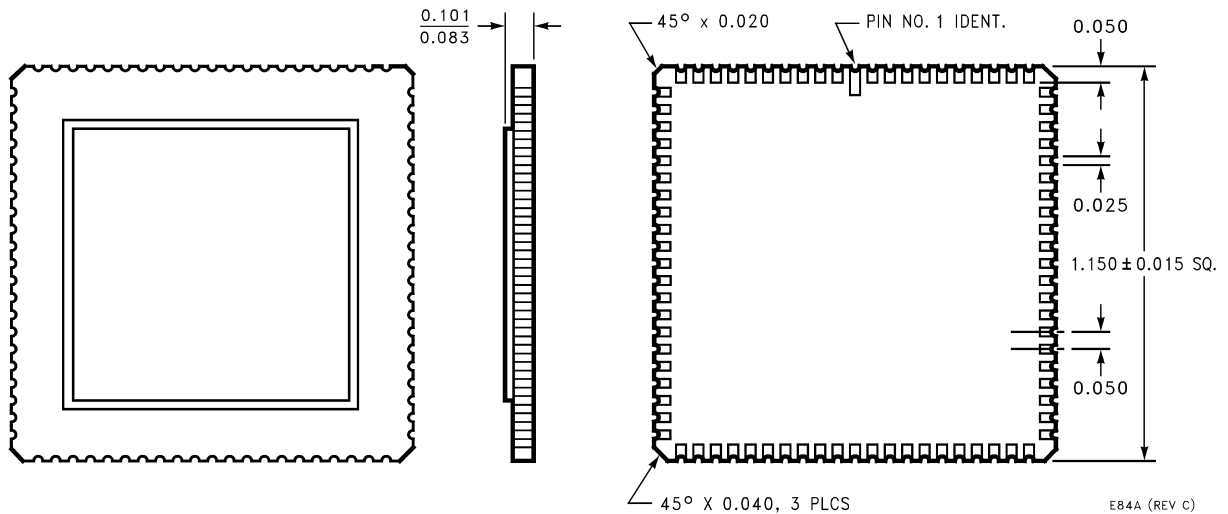

84 Lead Ceramic Leadless Chip Carrier, Type B NS Package Number E84B

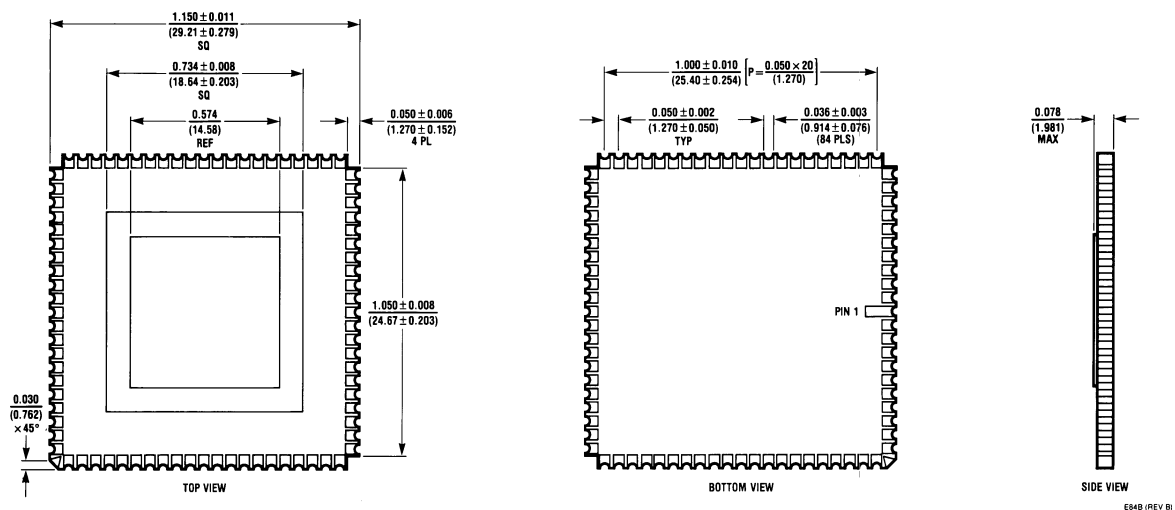

LIFE SUPPORT POLICY

NATIONAL'S PRODUCTS ARE NOT AUTHORIZED FOR USE AS CRITICAL COMPONENTS IN LIFE SUPPORT DEVICES OR SYSTEMS WITHOUT THE EXPRESS WRITTEN APPROVAL OF THE PRESIDENT AND GENERAL COUNSEL OF NATIONAL SEMICONDUCTOR CORPORATION. As used herein:

1. Life support devices or systems are devices or systems which, (a) are intended for surgical implant into the body, or (b) support or sustain life, and whose failure to perform when properly used in accordance with instructions for use provided in the labeling, can be reasonably expected to result in a significant injury to the user.
2. A critical component is any component of a life support device or system whose failure to perform can be reasonably expected to cause the failure of the life support device or system, or to affect its safety or effectiveness.



National Semiconductor Corporation
Americas
Tel: 1-800-272-9959
Fax: 1-800-737-7018
Email: support@nsc.com

www.national.com

National Semiconductor Europe
Fax: +49 (0) 1 80-530 85 86
Email: europe.support@nsc.com
Deutsch Tel: +49 (0) 1 80-530 85 85
English Tel: +49 (0) 1 80-532 78 32
Français Tel: +49 (0) 1 80-532 93 58
Italiano Tel: +49 (0) 1 80-534 16 80

National Semiconductor Asia Pacific Customer Response Group
Tel: 65-2544466
Fax: 65-2504466
Email: sea.support@nsc.com

National Semiconductor Japan Ltd.
Tel: 81-3-5639-7560
Fax: 81-3-5639-7507