

MNLM2990-5.0-X REV 0B1

 Original Creation Date: 04/30/96
 Last Update Date: 03/09/99
 Last Major Revision Date: 04/30/96

NEGATIVE LOW DROPOUT REGULATOR
General Description

The LM2990 is a low dropout, 1 ampere negative voltage regulator available with fixed output voltages of -5, -12, and -15V.

The LM2990 uses new circuit design techniques to provide low dropout and low quiescent current. The dropout voltage at 1A load current is typically 0.6V and a guaranteed worst-case maximum of 1V over the entire operating temperature range. The quiescent current is typically 1mA with 1A load current and an input-output voltage differential greater than 3V. A unique circuit design of the internal bias supply limits the quiescent current to only 9mA (typical) when the regulator is in the dropout mode ($V_{out} - V_{in} \leq 3V$). Output voltage accuracy is guaranteed to $\pm 5\%$ over load, and temperature extremes.

The LM2990 is short-circuit proof, and thermal shutdown includes hysteresis to enhance the reliability of the device when overloaded for an extended period of time.

Industry Part Number

LM2990

NS Part Numbers

 LM2990J-5.0-QML
 LM2990WG5.0-QML

Prime Die

LM2990

Controlling Document

SEE FEATURES SECTION

Processing

MIL-STD-883, Method 5004

Quality Conformance Inspection

MIL-STD-883, Method 5005

Subgrp Description Temp (°C)

1	Static tests at	+25
2	Static tests at	+125
3	Static tests at	-55
4	Dynamic tests at	+25
5	Dynamic tests at	+125
6	Dynamic tests at	-55
7	Functional tests at	+25
8A	Functional tests at	+125
8B	Functional tests at	-55
9	Switching tests at	+25
10	Switching tests at	+125
11	Switching tests at	-55

Features

- 5% output accuracy over entire operating range
- Output current in excess of 1A
- Dropout voltage typically 0.6V at 1A load
- Low quiescent current
- Internal short circuit current limit
- Internal thermal shutdown with hysteresis
- Functional complement to the LM2940 series
- CONTROLLING DOCUMENT:

LM2990J-5.0-QML	5962-9571101QEA
LM2990WG5.0-QML	5962-9571101QXA

Applications

- Post switcher regulator
- Local, on-card, regulation
- Battery operated equipment

(Absolute Maximum Ratings)

(Note 1)

Input Voltage	-26V to +0.3V
Power Dissipation (Note 2, 3)	Internally Limited
Operating Temperature Range (Tj)	-55 C to +125 C
Maximum Junction Temperature (Tjmax)	150 C
Storage Temperature Range	-65 C to +150 C
Lead Temperature (Soldering, 10 seconds)	260 C
Thermal Resistance	
ThetaJA	
CERAMIC DIP	
(Still Air @ 0.5 C/W)	75 C/W
(500LF/Min Air Flow @ 0.5 C/W)	35 C/W
CERAMIC SOIC	
(Still Air @ 0.5 C/W)	119 C/W
(500LF/Min Air Flow @ 0.5 C/W)	73 C/W
(Note 3)	
ThetaJC	
CERAMIC DIP	5 C/W
CERAMIC SOIC	3 C/W
Package Weight (Typical)	
CERAMIC DIP	TBD
CERAMIC SOIC	TBD
ESD Susceptibility (Note 4)	2kV

Note 1: Absolute Maximum Ratings indicate limits beyond which damage to the device may occur. Operating Ratings indicate conditions for which the device is functional, but do not guarantee specific performance limits. For guaranteed specifications and test conditions, see the Electrical Characteristics. The guaranteed specifications apply only for the test conditions listed. Some performance characteristics may degrade when the device is not operated under the listed test conditions.

Note 2: The maximum power dissipation must be derated at elevated temperatures and is dictated by Tjmax (maximum junction temperature), ThetaJA (package junction to ambient thermal resistance), and TA (ambient temperature). The maximum allowable power dissipation at any temperature is $P_{dmax} = (T_{jmax} - TA) / \Theta_{JA}$ or the number given in the Absolute Maximum Ratings, whichever is lower. If this dissipation is exceeded, the die temperature will rise above 125 C, and the LM2990 will eventually go into thermal shutdown at a Tj of approximately 160 C.

Note 3: The package material for these devices allows much improved heat transfer over our standard ceramic packages. In order to take full advantage of this improved heat transfer, heat sinking must be provided between the package base (directly beneath the die), and either metal traces on, or thermal vias through, the printed circuit board. Without this additional heat sinking, device power dissipation must be calculated using junction-to-ambient, rather than junction-to-case, thermal resistance. It must not be assumed that the device leads will provide substantial heat transfer out of the package, since the thermal resistance of the leadframe material is very poor, relative to the material of the package base. The stated junction-to-case thermal resistance is for the package material only, and does not account for the additional thermal resistance between the package base and the printed circuit board. The user must determine the value of the additional thermal resistance and must combine this with the stated value for the package, to calculate the total allowed power dissipation for the device.

Note 4: Human body model, 100pF discharged through a 1.5K Ohms resistor.

Recommended Operating Conditions

(Note 1)

Maximum Input Voltage (Operational)

-26V

Note 1: Absolute Maximum Ratings indicate limits beyond which damage to the device may occur. Operating Ratings indicate conditions for which the device is functional, but do not guarantee specific performance limits. For guaranteed specifications and test conditions, see the Electrical Characteristics. The guaranteed specifications apply only for the test conditions listed. Some performance characteristics may degrade when the device is not operated under the listed test conditions.

Electrical Characteristics

DC PARAMETERS

(The following conditions apply to all the following parameters, unless otherwise specified.)
DC: $V_{in} = -5V + V_o(NOM)$, $I_o = 1A$, $C_o = 47\mu F$.

SYMBOL	PARAMETER	CONDITIONS	NOTES	PIN-NAME	MIN	MAX	UNIT	SUB-GROUPS
Vo	Output Voltage	$5mA \leq I_o \leq 1A$	1		-5.10	-4.90	V	1
		$5mA \leq I_o \leq 1A$	1		-5.25	-4.75	V	2, 3
Vrln	Line Regulation	$I_o = 5mA$, $V_o(NOM) -1V > V_{in} > -26V$	1			40	mV	1, 2, 3
Vrld	Load Regulation	$50mA \leq I_o \leq 1A$	1			70	mV	1
		$50mA \leq I_o \leq 1A$	1			100	mV	2, 3
Vdo	Dropout Voltage	$I_o = 0.1A$, $\Delta V_o \leq 100mV$	1			0.3	V	1, 2, 3
		$I_o = 1A$, $\Delta V_o \leq 100mV$	1			1	V	1, 2, 3
Iq	Quiescent Current	$I_o \leq 1A$	1			5	mA	1
		$I_o \leq 1A$	1			10	mA	2, 3
		$I_o = 1A$, $V_{in} = V_o(NOM)$	1			50	mA	1, 2, 3
Ios	Short Circuit Current	$R_l = 1 \text{ Ohm}$	1, 2		1.5		A	1
			1, 2		1.3		A	2, 3
Imax	Maximum Output Current		1, 2		1.5		A	1
Rr	Ripple Rejection	$V_{ripple} = 1V_{rms}$, $F_{ripple} = 1KHz$, $I_o = 5mA$	1		50		dB	1
Von	Output Noise Voltage	10Hz-100Khz, $I_o = 5mA$	1			750	μV	1, 2, 3

Note 1: $V_o(NOM)$ is the nominal (typical) regulator output voltage, -5V, -12V or -15V.

Note 2: The short circuit current is less than the maximum output current with the -12V and -15V versions due to internal foldback current limiting. The -5V version tested with a lower input voltage, does not reach the foldback current limit and therefore conducts a higher short circuit level. If the LM2990 output is pulled above ground, the maximum allowed current sunk back into the LM2990 is 1.5A.

Graphics and Diagrams

GRAPHICS#	DESCRIPTION
06324HRB3	CERDIP (J), 16 LEAD (B/I CKT)
06350HRA1	CERAMIC SOIC (WG), 16 LEAD (B/I CKT)
J16ARL	CERDIP (J), 16 LEAD (P/P DWG)
P000100B	CERDIP (J), 16 LEAD (PIN OUT)
P000383A	CERAMIC SOIC (WG), 16 LEAD (PINOUT)
WG16ARC	CERAMIC SOIC (WG), 16 LEAD (P/P DWG)

See attached graphics following this page.

GENERAL NOTES:

1. GENERIC - INDUSTRY TYPE DEVICES THAT MAY BE USED WITH THIS CIRCUIT SHALL BE AS SPECIFIED IN NSC BURN-IN CIRCUIT LIST R512B-04.
2. ALL 1/4 AND 1/2 WATT RESISTORS SHALL BE METAL FILM. ALL 1, 2, AND 3 WATT RESISTORS SHALL BE WIRE WOUND. TOLERANCE SHALL BE +/-5% UNLESS OTHERWISE SPECIFIED.
3. ALL VOLTAGES SPECIFIED SHALL BE MEASURED AT THE "DEVICE UNDER TEST" PIN AND SHALL BE MINIMUM VALUES UNLESS OTHERWISE SPECIFIED.
4. WHEN APPLICABLE, CLOCK PULSES SPECIFIED SHALL HAVE 50% DUTY CYCLE.
5. THIS DRAWING COMPLIES WITH MIL-PRF-38535, WHEN APPLICABLE.

ECN	REV	APPROVALS	DATE
07374	A1	J.GOMEZ	12/9/97

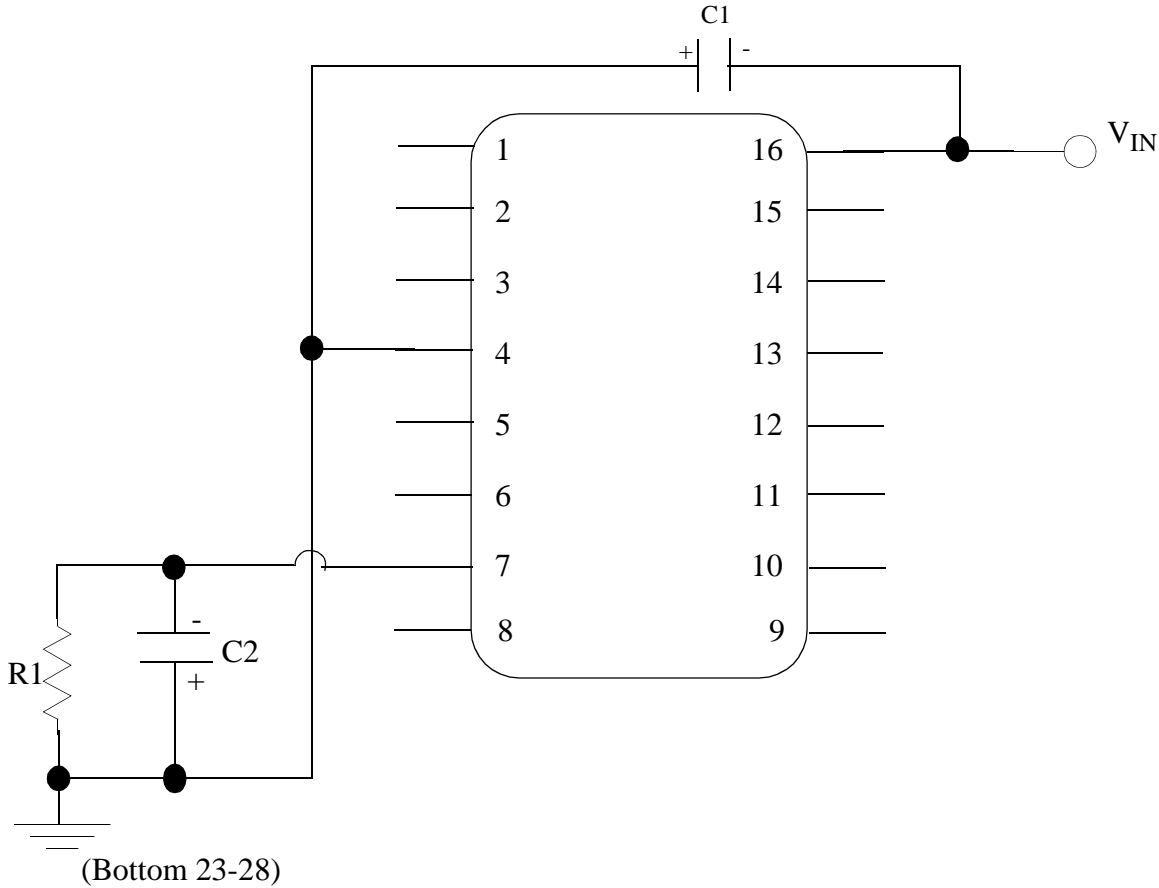

DUT CONDITIONS				COMPONENT REQUIREMENTS PER POSITION					
SYMBOL	LIMITS		UNITS	SYMBOL	LIMITS	UNITS	REF DESIG.	QTY	DESCRIPTION
	MIN.	MAX.							
VIN	-26	-25	VOLTS				R1	1	2.4K OHMS, 1/4 WATT
							C1	1	0.1uF, 50V
							C2	1	47uF, 50V

NOTES:
 6. I Max 8.0mA, PD = 208mW
 7. LM2990-5.0, LM2990-12, LM2990-15
 8. TEMP. = 125°C
 9. T_{JMAX} = 130°C AT 125°C BURN IN.

National Semiconductor
 MIL/AEROSPACE OPERATIONS
 2900 SEMICONDUCTOR DRIVE
 SANTA CLARA, CA 95050

BURN-IN CIRCUIT						SH	OF	1
CUSTOMER			PACKAGE TYPE	MIL	NSC	TEST CONDITION		
ORIGINATOR			DATE	CHECKED BY	DATE	DRAWING NUMBER		REV
J.GOMEZ			12/9/97			06350HR		A1

R E V I S I O N S			
LTR	DESCRIPTION	E. C. N.	DATE
L	REVISE PER CURRENT STD; REDRAW	09996	09/15/93
			BY/APP'D TL/

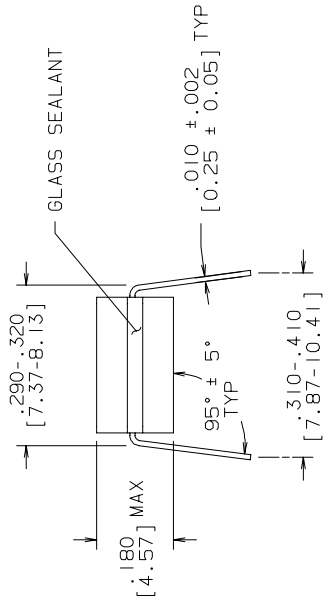
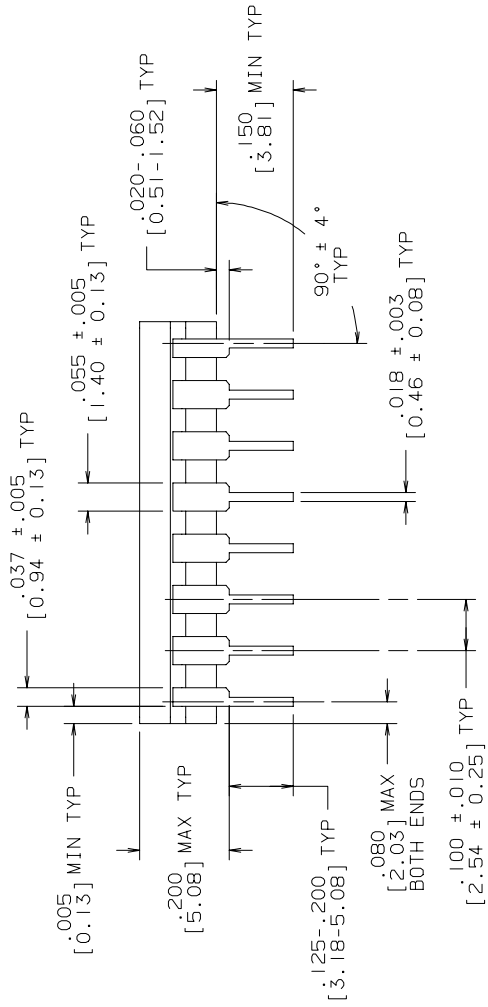
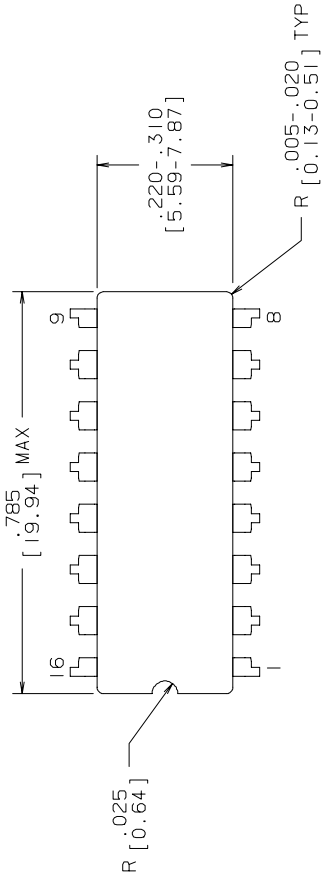

MILIAERO
CONFIGURATION CONTROL

MIL-M-38510
CONFIGURATION CONTROL

CONTROLLING DIMENSION: INCH			
APPROVALS	DATE		
DRAWN T. LEQUANG	09/15/93		
DFTG. CHK.			
ENGR. CHK.			
APPROVAL			
PROJECTION 			
	INCH [MM]		
SCALE	SIZE	DRAWING NUMBER	REV
N/A	B	MKT-J16A	L
DO NOT SCALE DRAWING	SHEET	1	OF 1

NOTES: UNLESS OTHERWISE SPECIFIED

1. LEAD FINISH TO BE 200 MICROMETERS / 5.08 MICROMETERS MINIMUM SOLDER MEASURED AT THE CREST OF THE MAJOR FLATS.
2. JEDEC REGISTRATION MO-036, VARIATION AD, DATED 04/1981.

NATIONAL SEMICONDUCTOR CORPORATION
2900 Semiconductor Drive, Santa Clara, CA 95052-8090

CERDIP (J),
16 LEAD

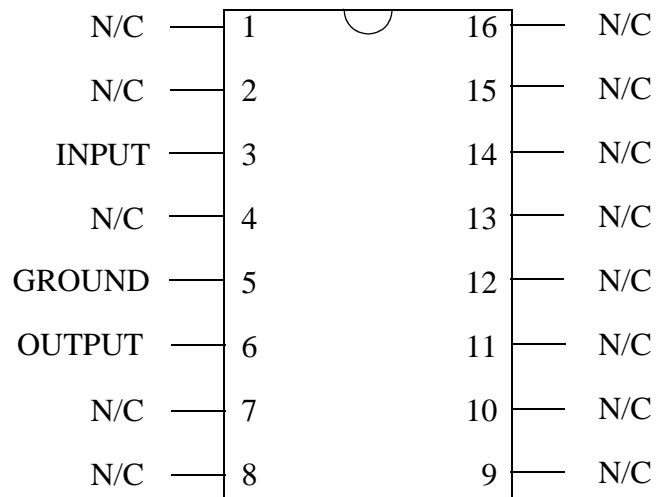

LM2990J-XX
16 - LEAD DIP
CONNECTION DIAGRAM
(TOP VIEW)
P000100B



National Semiconductor™
MIL/AEROSPACE OPERATIONS
2900 SEMICONDUCTOR DRIVE
SANTA CLARA, CA 95050

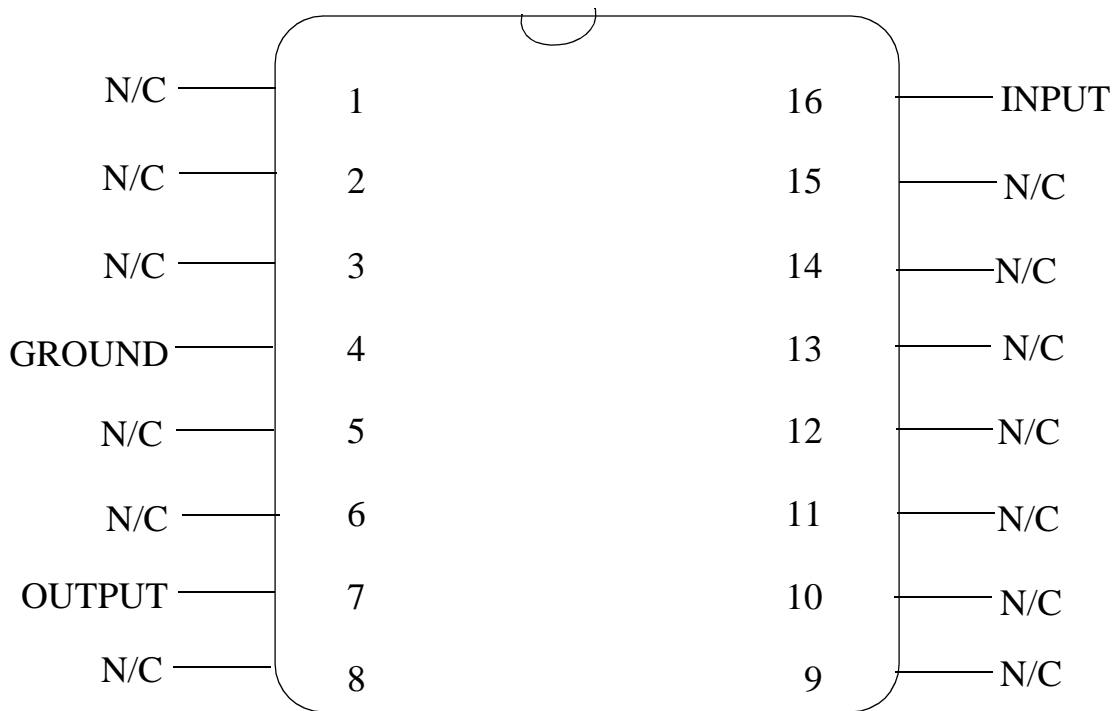

LM2990WG
16 - LEAD CERAMIC SOIC
CONNECTION DIAGRAM
TOP VIEW
P000383A

REVISIONS			
LTR	DESCRIPTION	E.C.N.	DATE
A	RELEASE TO DOCUMENT CONTROL	11376	02/29/1996
B	LD PITCH TOL WAS ±.005; CHANGE LD RADIUS TO REF DIM; REMOVE THE OTHER R.006±.002; DIM. .040±.003 WAS .037±.003	11443	04/19/1996
C	R.015(0.38) WAS R.006(0.15)	11840	10/08/1997

APPROVALS	DATE	BY/APP'D
DRN: <i>MARYA SUCHY</i>	02/29/96	MS/KH
ENGR. CHK.		MS/KH
PROJECTION		
		
SCALE	SIZE	REV
N/A	C	C
DO NOT SCALE DRAWING		

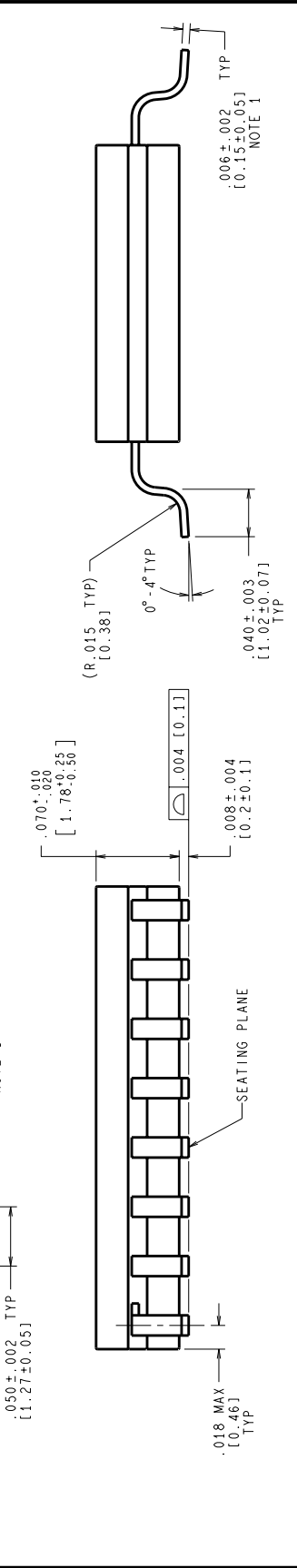
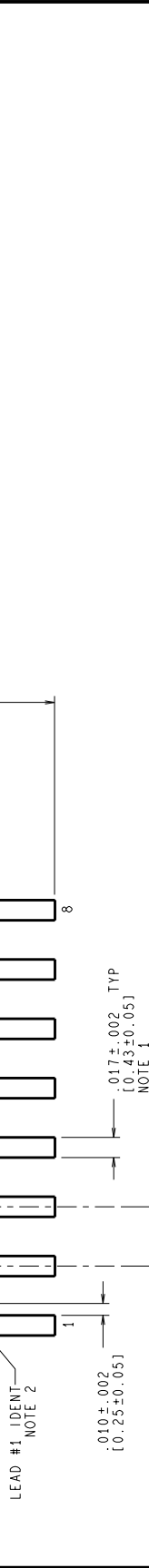
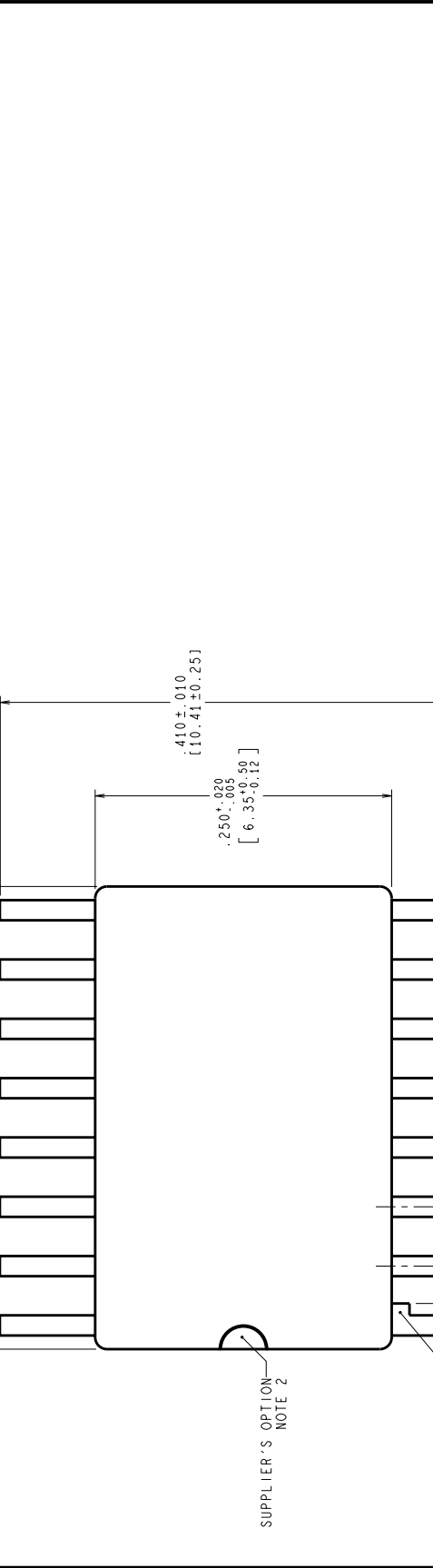

**MIL-PRF-38535
CONFIGURATION CONTROL**

CONTROLLING DIMENSION IS INCH
VALUES IN | ARE MILLIMETERS

- NOTES: UNLESS OTHERWISE SPECIFIED
- LEAD FINISH: SOLDER DIPPED WITH Sn60 OR Sn63 SOLDER CONFORMING TO MIL-PRF-38535 TO A MINIMUM THICKNESS OF 200 MICRONS / 5.08 MICROMETERS. SOLDER MAY BE APPLIED OVER LEAD BASIS METAL OR Sn PLATE. MAXIMUM LIMIT MAY BE INCREASED BY .003 IN/ 0.08mm AFTER LEAD FINISH APPLIED.
 - LEAD 1 IDENTIFICATION SHALL BE:
 - A NOTCH OR OTHER MARK WITHIN THIS AREA
 - A TAB ON LEAD 1, EITHER SIDE
 - NO JEDEC REGISTRATION AS OF FEBRUARY 1996.

		National Semiconductor	
2800 Semiconductor Dr., Santa Clara, CA 95052-8000		CERPACK, 16 LEAD, GULL WING	
SCALE	SIZE	DRAWING NUMBER	REV
N/A	C	(SC)MKT-WG16A	C

Revision History

Rev	ECN #	Rel Date	Originator	Changes
0A0	M0000595	03/09/99	Barbara Lopez	Initial Release of: MNLM2990-5.0-X Rev. 0A0. Added note for power dissipation and reference thermal resistance for Aluminum Nitride package.
0B1	M0003232	03/09/99	Rose Malone	Update MDS: MNLM2990-5.0-X, Rev. 0A0 to MNLM2990-5.0-X, Rev. 0B1.