

LMH0307

3 Gbps HD/SD SDI Dual Output Cable Driver with Cable Detect

General Description

The LMH0307 3 Gbps HD/SD SDI Dual Output Cable Driver with Cable Detect is designed for use in SMPTE 424M, SMPTE 292M, SMPTE 344M, and SMPTE 259M serial digital video applications. The LMH0307 implements two complementary output drivers and drives 75 Ω transmission lines (Belden 1694A, Belden 8281, or equivalent) at data rates up to 2.97 Gbps.

The LMH0307 includes intelligent sensing capabilities to improve system diagnostics. The cable detect feature senses near-end termination to determine if a cable is correctly attached to the output BNC. Input loss of signal (LOS) detects the presence of a valid signal at the input of the cable driver. These sensing features may be used to alert the user of a system fault and activate a deep power save mode, reducing the cable driver's power consumption to 3 mW. These features are accessible via an SMBus interface.

The LMH0307 provides two selectable slew rates for SMPTE 259M and SMPTE 424M / 292M compliance. The output amplitude is adjustable $\pm 10\%$ in 5 mV steps via the SMBus.

The LMH0307 is powered from a single 3.3V supply. Power consumption is typically 230 mW in SD mode and 275 mW in HD mode. The LMH0307 is available in two space-saving packages: a 4 x 4 mm 16-pin LLP and even more space-efficient 3 x 3 mm 25-ball MICRO-ARRAY package.

The LMH0307 interfaces with National's LMH0356 for additional system control and power consumption savings (see *Typical Application*).

Features

- SMPTE 424M, SMPTE 292M, SMPTE 344M, and SMPTE 259M compliant
- Data rates to 2.97 Gbps
- Supports DVB-ASI at 270 Mbps
- Cable detect on output
- Loss of signal detect at input
- Output driver power down control
- Typical power consumption: 230 mW in SD mode and 275 mW in HD mode
- Power save mode typical power consumption: 4 mW
- Single 3.3V supply operation
- Differential input
- Dual complementary 75 Ω outputs
- Selectable slew rate
- Industrial temperature range: -40°C to $+85^{\circ}\text{C}$
- 16-pin LLP or 25-ball MICRO-ARRAY package

Applications

- SMPTE 424M, SMPTE 292M, SMPTE 344M, and SMPTE 259M serial digital interfaces
- Digital video routers and switches
- Distribution amplifiers

Typical Application

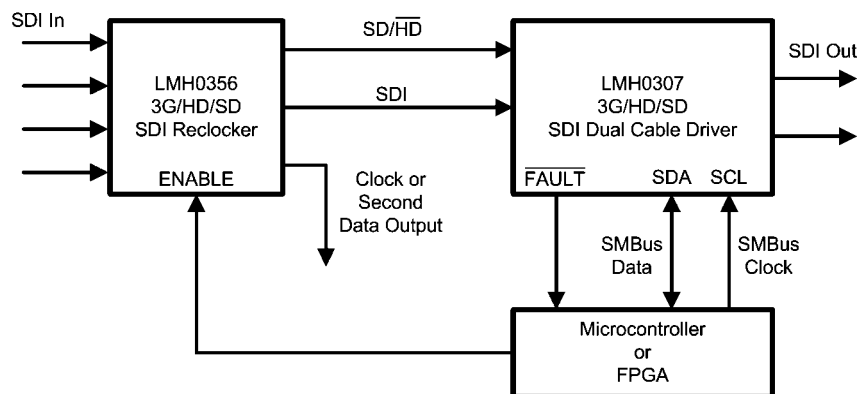

30047903

Absolute Maximum Ratings (Note 1)

Supply Voltage:	-0.5V to 3.6V
Input Voltage (all inputs)	-0.3V to $V_{CC}+0.3V$
Output Current	28 mA
Storage Temperature Range	-65°C to +150°C
Junction Temperature	+125°C
Lead Temperature (Soldering 4 Sec)	+260°C
Package Thermal Resistance	
θ_{JA} 16-pin LLP	+43°C/W
θ_{JC} 16-pin LLP	+7°C/W
θ_{JA} 25-ball MICRO-ARRAY	+67.6°C/W

ESD Rating (HBM)	8 kV
ESD Rating (MM)	400V
ESD Rating (CDM)	2 kV

Recommended Operating Conditions

Supply Voltage ($V_{CC} - V_{EE}$):	3.3V ±5%
Operating Free Air Temperature (T_A)	-40°C to +85°C

DC Electrical Characteristics

Over Supply Voltage and Operating Temperature ranges, unless otherwise specified (Notes 2, 3).

Symbol	Parameter	Conditions	Reference	Min	Typ	Max	Units
V_{CMIN}	Input Common Mode Voltage		SDI, \overline{SDI}	1.6 + $V_{SDI}/2$		$V_{CC} -$ $V_{SDI}/2$	V
V_{SDI}	Input Voltage Swing	Differential		100		2200	mV _{P-P}
V_{CMOUT}	Output Common Mode Voltage		SDO, \overline{SDO}		$V_{CC} -$ V_{SDO}		V
V_{SDO}	Output Voltage Swing	Single-ended, 75Ω load, $R_{REF} = 750\Omega$ 1%		720	800	880	mV _{P-P}
V_{IH}	Input Voltage High Level		SD/ \overline{HD} ,	2.0			V
V_{IL}	Input Voltage Low Level		ENABLE			0.8	V
I_{CC}	Supply Current	SD/ $\overline{HD} = 0$, SDO/ \overline{SDO} enabled			84	100	mA
		SD/ $\overline{HD} = 1$, SDO/ \overline{SDO} enabled			70	77	mA
		SDO/ \overline{SDO} disabled			1.3	2.5	mA

SMBus DC Specifications

V_{SIL}	Data, Clock Input Low Voltage					0.8	V
V_{SIH}	Data, Clock Input High Voltage			2.1		V_{SDD}	V
$I_{SPULLUP}$	Current through pullup resistor or current source	$V_{OL} = 0.4V$		4			mA
V_{SDD}	Nominal Bus Voltage			3.0		3.6	V
I_{SLEAKB}	Input Leakage per bus segment	(Note 6)		-200		200	μA
I_{SLEAKP}	Input Leakage per pin			-10		10	μA
C_{SI}	Capacitance for SDA and SCL	(Notes 6, 7)				10	pF

AC Electrical Characteristics

Over Supply Voltage and Operating Temperature ranges, unless otherwise specified (Note 3).

Symbol	Parameter	Conditions	Reference	Min	Typ	Max	Units
DR_{SDI}	Input Data Rate		SDI, \overline{SDI}			2970	Mbps
t_{jit}	Additive Jitter	2.97 Gbps	SDO, \overline{SDO}		20		ps _{P-P}
		1.485 Gbps			18		ps _{P-P}
		270 Mbps			15		ps _{P-P}
t_r, t_f	Output Rise Time, Fall Time	$SD/\overline{HD} = 0, 20\% - 80\%$,			90	130	ps
		$SD/\overline{HD} = 1, 20\% - 80\%$		400		800	ps
	Mismatch in Rise/Fall Time	$SD/\overline{HD} = 0$				30	ps
		$SD/\overline{HD} = 1$				50	ps
	Duty Cycle Distortion	$SD/\overline{HD} = 0, 2.97$ Gbps, (Note 4)				27	ps
		$SD/\overline{HD} = 0, 1.485$ Gbps, (Note 4)				30	ps
		$SD/\overline{HD} = 1, (Note 4)$				100	ps
t_{OS}	Output Overshoot	$SD/\overline{HD} = 0, (Note 4)$				10	%
		$SD/\overline{HD} = 1, (Note 4)$				8	%
t_{SK}	SDO1 to SDO0 Skew	$SD/\overline{HD} = 0, (Note 4)$				8	ps
		$SD/\overline{HD} = 1, (Note 4)$				54	ps
RL_{SDO}	Output Return Loss	5 MHz - 1.5 GHz, (Note 5)		15			dB
		1.5 GHz - 3.0 GHz, (Note 5)		10			dB

SMBus AC Specifications

f_{SMB}	Bus Operating Frequency			10		100	kHz
t_{BUF}	Bus free time between Stop and Start Condition			4.7			μs
$t_{HD:STA}$	Hold time after (repeated) Start Condition. After this period, the first clock is generated.	At $I_{SPULLUP} = MAX$		4.0			μs
$t_{SU:STA}$	Repeated Start Condition setup time			4.7			μs
$t_{SU:STO}$	Stop Condition setup time			4.0			μs
$t_{HD:DAT}$	Data hold time			300			ns
$t_{SU:DAT}$	Data setup time			250			ns
t_{LOW}	Clock low period			4.7			μs
t_{HIGH}	Clock high period			4.0		50	μs
t_F	Clock/Data Fall Time					300	ns
t_R	Clock/Data Rise Time					1000	ns
t_{POR}	Time in which device must be operational after power on					500	ms

Note 1: "Absolute Maximum Ratings" are those parameter values beyond which the life and operation of the device cannot be guaranteed. The stating herein of these maximums shall not be construed to imply that the device can or should be operated at or beyond these values. The table of "Electrical Characteristics" specifies acceptable device operating conditions.

Note 2: Current flow into device pins is defined as positive. Current flow out of device pins is defined as negative. All voltages are stated referenced to $V_{EE} = 0$ Volts.

Note 3: Typical values are stated for $V_{CC} = +3.3V$ and $T_A = +25^\circ C$.

Note 4: Specification is guaranteed by characterization.

Note 5: Output return loss is dependent on board design. The LMH0307 meets this specification on the SD307 evaluation board.

Note 6: Recommended value — Parameter not tested.

Note 7: Recommended maximum capacitive load per bus segment is 400 pF.

Timing Diagram

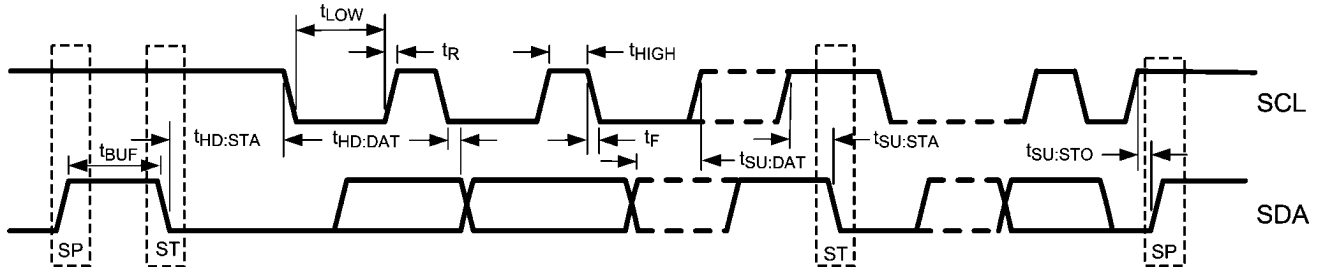

SMBus Timing Parameters

30047906

Connection Diagrams

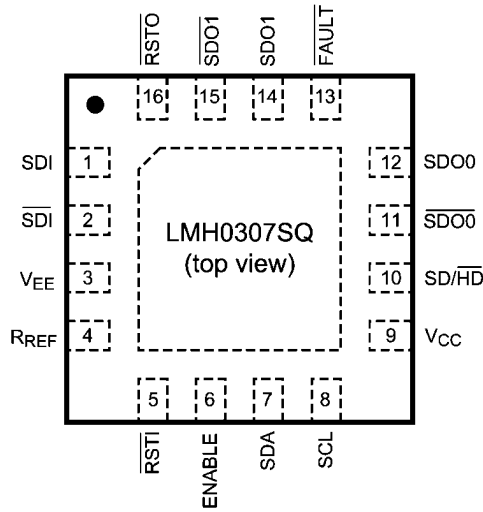

30047905

The exposed die attach pad is a negative electrical terminal for this device. It should be connected to the negative power supply voltage.

16-Pin LLP
Order Number LMH0307SQ
See NS Package Number SQB16A

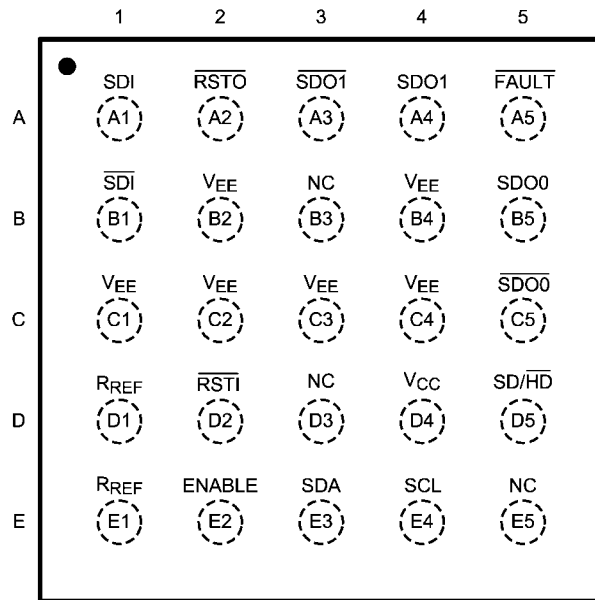

LMH0307GR
(top view)

25-Ball MICRO-ARRAY
Order Number LMH0307GR
See NS Package Number GRA25A

30047908

Pin Descriptions

LLP Pin	MICRO-ARRAY Ball	Name	Description
1	A1	SDI	Serial data true input.
2	B1	$\overline{\text{SDI}}$	Serial data complement input.
4	D1, E1	R_{REF}	Bias resistor. Connect a 750 Ω resistor to V_{CC} (also connect D1 to E1 on MICRO-ARRAY version).
5	D2	$\overline{\text{RSTI}}$	Reset input. H = Normal operation. L = Device reset. The device operates with default register settings. Forcing $\overline{\text{RSTI}}$ low also forces $\overline{\text{RSTO}}$ low.
6	E2	ENABLE	Output driver enable (with internal pullup). H = Normal operation. L = Output driver powered off.
7	E3	SDA	SMBus bidirectional data pin. When functioning as an output, it is open drain. This pin requires an external pullup.
8	E4	SCL	SMBus clock input. SCL is input only. This pin requires an external pullup.
10	D5	SD/HD	Output slew rate control. H = Output rise/fall time complies with SMPTE 259M. L = Output rise/fall time complies with SMPTE 424M / 292M.
11	C5	$\overline{\text{SDO0}}$	Serial data output 0 complement output.
12	B5	SDO0	Serial data output 0 true output.
13	A5	$\overline{\text{FAULT}}$	Fault open drain output flag. Requires external pullup resistor and may be wire ORed with multiple cable drivers. H = Normal operation. L = Loss of signal or termination fault for any output.
14	A4	SDO1	Serial data output 1 true output.
15	A3	$\overline{\text{SDO1}}$	Serial data output 1 complement output.
16	A2	$\overline{\text{RSTO}}$	Reset output. $\overline{\text{RSTO}}$ is automatically set to 1 when register 0 is written. It can be reset back to zero by forcing $\overline{\text{RSTI}}$ to zero to reset the device. Used to daisy chain multiple cable drivers on the same SMBus.
9	D4	V_{CC}	Positive power supply (+3.3V).
DAP, 3	B2, B4, C1, C2, C3, C4	V_{EE}	Negative power supply (ground).
—	B3, D3, E5	NC	No connect.

Device Operation

INPUT INTERFACING

The LMH0307 accepts either differential or single-ended input. For single-ended operation, the unused input must be properly terminated.

OUTPUT INTERFACING

The LMH0307 uses current mode outputs. Single-ended output levels are 800 mV_{P-P} into 75Ω AC-coupled coaxial cable with an R_{REF} resistor of 750Ω. The R_{REF} resistor is connected between the R_{REF} pin and V_{CC}. The only resistor value that should be used for R_{REF} is 750Ω.

The R_{REF} resistor should be placed as close as possible to the R_{REF} pin. In addition, the copper in the plane layers below the R_{REF} network should be removed to minimize parasitic capacitance.

OUTPUT SLEW RATE CONTROL

The LMH0307 output rise and fall times are selectable for either SMPTE 259M or SMPTE 424M / 292M compliance via the SD/H \bar{D} pin. For slower rise and fall times, or SMPTE 259M compliance, SD/H \bar{D} is set high. For faster rise and fall times, or SMPTE 424M and SMPTE 292M compliance, SD/H \bar{D} is set low. SD/H \bar{D} may also be controlled using the SMBus, provided the SD/H \bar{D} pin is held low.

OUTPUT ENABLE

The SDO0/S $\bar{D}O\bar{0}$ and SDO1/S $\bar{D}O\bar{1}$ output drivers can be enabled or disabled with the ENABLE pin. When set low, both output drivers are powered off and the LMH0307 enters a deep power save mode. ENABLE has an internal pullup.

INPUT LOSS OF SIGNAL DETECTION ($\bar{L}O\bar{S}$)

The LMH0307 detects when the input signal does not have a video-like pattern. Self oscillation and low levels of noise are rejected. This loss of signal detect allows a very sensitive input stage that is robust against coupled noise without any degradation of jitter performance.

Via the SMBus, the loss of signal detect can either add an input offset or mute the outputs. An offset is added by default. Additionally, the loss of signal detect can be linked to the ENABLE functionality so that when the $\bar{L}O\bar{S}$ goes low, ENABLE will also go low.

OUTPUT CABLE DETECTION

The LMH0307 detects when an output is locally terminated. When a video signal (or AC test signal) is present on SDI, the device senses the SDO and S $\bar{D}O$ amplitudes. If the output is not properly terminated (via a terminated cable or local termination), the amplitude will be higher than expected, and the Termination Fault signal is asserted. The Termination Fault signal is de-asserted when the proper termination is applied. This feature allows the system designer the flexibility to react to cable attachment and removal. Note that a long length of cable will look like a proper termination at the device output.

The cable driver must be enabled for the termination detection to operate. If the Termination Fault will be used to power down the LMH0307, then periodic polling (enabling) is recommended to monitor the output termination. For example, when a Fault condition is triggered, ENABLE can be driven low to power down the device. The LMH0307 should be re-enabled periodically to check the status of the output termination. The LMH0307 needs to be powered on for roughly 4 ms for Termination Fault detection to work.

SMBus Interface

The System Management Bus (SMBus) is a two-wire interface designed for the communication between various system component chips. By accessing the control functions of the circuit via the SMBus, pincount is kept to a minimum while allowing a maximum amount of versatility. The LMH0307 has several internal configuration registers which may be accessed via the SMBus.

The 7-bit default address for the LMH0307 is 17h. The LSB is set to 0b for a WRITE and 1b for a READ, so the 8-bit default address for a WRITE is 2Eh and the 8-bit default address for a READ is 2Fh. The SMBus address may be dynamically changed.

In applications where there might be several LMH0307s, the SDA, SCL, and FAULT pins can be shared. The SCL, SDA, and FAULT pins are open drain and require external pullup resistors. Multiple LMH0307s may have the FAULT pin wire ORed. This signal becomes active when either loss of signal is detected or any termination faults are detected. The registers may be read in order to determine the cause. Additionally, each signal can be masked from the FAULT pin.

TRANSFER OF DATA VIA THE SMBus

During normal operation the data on SDA must be stable during the time when SCL is High.

There are three unique states for the SMBus:

START: A High-to-Low transition on SDA while SCL is High indicates a message START condition.

STOP: A Low-to-High transition on SDA while SCL is High indicates a message STOP condition.

IDLE: If SCL and SDA are both High for a time exceeding t_{BUF} from the last detected STOP condition or if they are High for a total exceeding the maximum specification for t_{HIGH} then the bus will transfer to the IDLE state.

SMBus TRANSACTIONS

The device supports WRITE and READ transactions. See Register Description table for register address, type (Read/Write, Read Only), default value and function information.

WRITING A REGISTER

To write a register, the following protocol is used (see SMBus 2.0 specification).

1. The Host drives a START condition, the 7-bit SMBus address, and a "0" indicating a WRITE.
2. The Device (Slave) drives the ACK bit ("0").
3. The Host drives the 8-bit Register Address.
4. The Device drives an ACK bit ("0").
5. The Host drives the 8-bit data byte.
6. The Device drives an ACK bit ("0").
7. The Host drives a STOP condition.

The WRITE transaction is completed, the bus goes IDLE and communication with other SMBus devices may now occur.

READING A REGISTER

To read a register, the following protocol is used (see SMBus 2.0 specification).

1. The Host drives a START condition, the 7-bit SMBus address, and a "0" indicating a WRITE.
2. The Device (Slave) drives the ACK bit ("0").
3. The Host drives the 8-bit Register Address.
4. The Device drives an ACK bit ("0").
5. The Host drives a START condition.
6. The Host drives the 7-bit SMBus Address, and a "1" indicating a READ.

7. The Device drives an ACK bit "0".
8. The Device drives the 8-bit data value (register contents).
9. The Host drives a NACK bit "1" indicating end of the READ transfer.
10. The Host drives a STOP condition.

Application Information

Figure 1 shows the application circuit for the LMH0307.

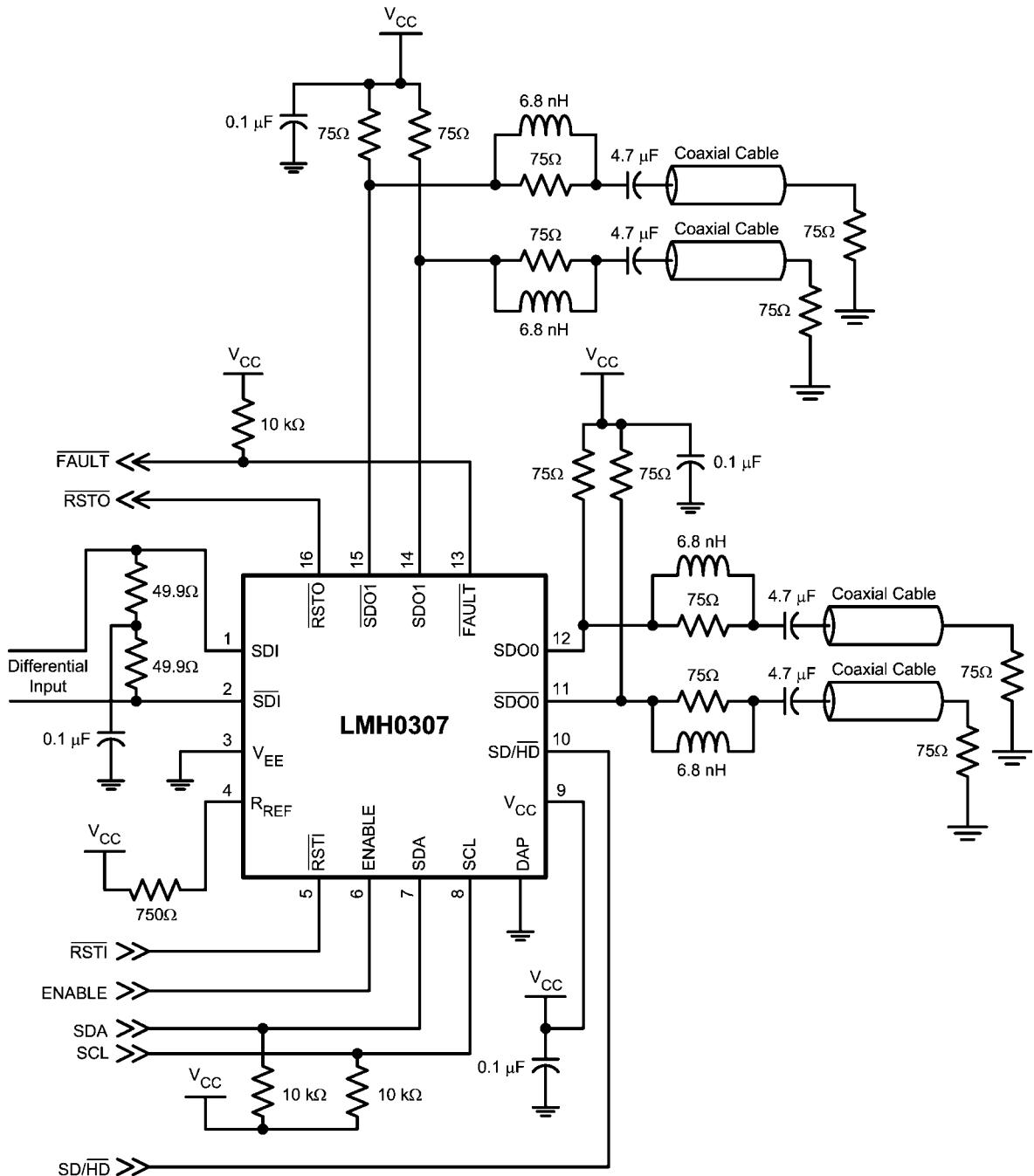

30047902

FIGURE 1. Application Circuit

COMMUNICATING WITH MULTIPLE LMH0307 CABLE DRIVERS VIA THE SMBus

A common application for the LMH0307 will utilize multiple cable driver devices. Even though the LMH0307 devices all have the same default SMBus device ID (address), it is still

possible for them share the SMBus signals as shown in Figure 2. A third signal is required from the host to the first device. This signal acts as a "Enable / Reset" signal. Additional LMH0307s are controlled from the upstream device. In this control scheme, multiple LMH0307s may be controlled

via the two-wire SMBus and the use of one GPO (General Purpose Output) signal. Other SMBus devices may also be

connected to the two wires, assuming they have their own unique SMBus addresses.

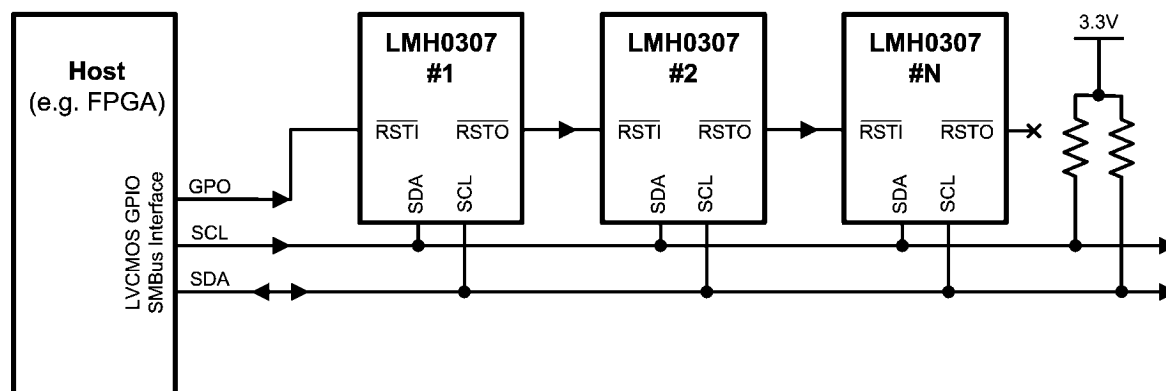

30047907

FIGURE 2. SMBus Configuration for Multiple LMH0307 Cable Drivers

The $\overline{\text{RSTI}}$ pin of the first device is controlled by the system with a GPO pin from the host. The first LMH0307 $\overline{\text{RSTO}}$ pin is then daisy chained to the next device's $\overline{\text{RSTI}}$ pin. That device's $\overline{\text{RSTO}}$ pin is connected to the next device and so on.

The procedure at initialization is to:

1. Hold the host GPO pin Low in RESET, to the first device. $\overline{\text{RSTO}}$ output default is also Low which holds the next device in RESET in the chain.
2. Raise the host GPO signal to LMH0307 #1 $\overline{\text{RSTI}}$ input pin.
3. Write to Address 8'h2E (7'h17) Register 0 with the new address value (e.g. 8'h2C (7'h16)).
4. Upon writing Register 0 in LMH0307 #1, its $\overline{\text{RSTO}}$ signal will switch High. Its new address is 8'h2C (7'h16), and

the next LMH0307 in the chain will now respond to the default address of 8'h2E (7'h17).

5. The process is repeated until all LMH0307 devices have a unique address loaded.
6. Direct SMBus writes and reads may now take place between the host and any addressed device.

The 7-bit address field allows for 128 unique addresses. The above procedure allows for the reprogramming of the LMH0307 devices such that multiple devices may share the two-wire SMBus. Make sure all devices on the bus have unique device IDs.

If power is toggled to the system, the SMBus address routine needs to be repeated.

TABLE 1. SMBus Registers

Address	R/W	Name	Bits	Field	Default	Description
00h	R/W	ID	7:1	DEVID	0010111	Device ID. Writing this register will force the RSTO pin high. Further accesses to the device must use this 7-bit address.
			0	RSVD	0	Reserved as 0. Always write 0 to this bit.
01h	R	STATUS	7:5	RSVD	000	Reserved.
			4	TF1N	0	Termination Fault for $\overline{\text{SDI1}}$. 0: No Termination Fault Detected. 1: Termination Fault Detected.
			3	TF1P	0	Termination Fault for SDI1. 0: No Termination Fault Detected. 1: Termination Fault Detected.
			2	TF0N	0	Termination Fault for $\overline{\text{SDI0}}$. 0: No Termination Fault Detected. 1: Termination Fault Detected.
			1	TF0P	0	Termination Fault for SDI0. 0: No Termination Fault Detected. 1: Termination Fault Detected.
			0	LOS	0	Loss Of Signal ($\overline{\text{LOS}}$) detect at input. 0: No Signal Detected. 1: Signal Detected.
			02h	R/W	MASK	7
6	PD1	0				Power Down for SDO1 output stage. If the ENABLE pin is set to ground, it overrides this bit. With the ENABLE pin set to V_{CC} , PD1 functions as follows: 0: SDO1 active. 1: SDO1 powered down.
5	PD0	0				Power Down for SDO0 output stage. If the ENABLE pin is set to ground, it overrides this bit. With the ENABLE pin set to V_{CC} , PD0 functions as follows: 0: SDO0 active. 1: SDO0 powered down.
4	MTF1N	0				Mask TF1N from affecting $\overline{\text{FAULT}}$ pin. 0: TF1N=1 will cause $\overline{\text{FAULT}}$ to be 0. 1: TF1N=1 will not affect $\overline{\text{FAULT}}$; the condition is masked off.
3	MTF1P	0				Mask TF1P from affecting $\overline{\text{FAULT}}$ pin. 0: TF1P=1 will cause $\overline{\text{FAULT}}$ to be 0. 1: TF1P=1 will not affect $\overline{\text{FAULT}}$; the condition is masked off.
2	MTF0N	0				Mask TF0N from affecting $\overline{\text{FAULT}}$ pin. 0: TF0N=1 will cause $\overline{\text{FAULT}}$ to be 0. 1: TF0N=1 will not affect $\overline{\text{FAULT}}$; the condition is masked off.
1	MTF0P	0				Mask TF0P from affecting $\overline{\text{FAULT}}$ pin. 0: TF0P=1 will cause $\overline{\text{FAULT}}$ to be 0. 1: TF0P=1 will not affect $\overline{\text{FAULT}}$; the condition is masked off.
0	MLOS	0				Mask $\overline{\text{LOS}}$ from affecting $\overline{\text{FAULT}}$ pin. 0: $\overline{\text{LOS}}=0$ will cause $\overline{\text{FAULT}}$ to be 0. 1: $\overline{\text{LOS}}=0$ will not affect $\overline{\text{FAULT}}$; the condition is masked off.

Address	R/W	Name	Bits	Field	Default	Description
03h	R/W	DIRECTION	7	HDTF0ThreshLSB	1	Least Significant Bit for HDTF0Thresh detection threshold. Combines with HDTF0Thresh bits in register 04h.
			6	SDTF0ThreshLSB	1	Least Significant Bit for SDTF0Thresh detection threshold. Combines with SDTF0Thresh bits in register 05h.
			5	RSVD	0	Reserved as 0. Always write 0 to this bit.
			4	DTF1N	0	Direction of TF1N that affects $\overline{\text{FAULT}}$ pin (when not masked). 0: TF1N=1 will cause $\overline{\text{FAULT}}$ to be 0 (when the condition is not masked off). 1: TF1N=0 will cause $\overline{\text{FAULT}}$ to be 0 (when the condition is not masked off).
			3	DTF1P	0	Direction of TF1P that affects $\overline{\text{FAULT}}$ pin (when not masked). 0: TF1P=1 will cause $\overline{\text{FAULT}}$ to be 0 (when the condition is not masked off). 1: TF1P=0 will cause $\overline{\text{FAULT}}$ to be 0 (when the condition is not masked off).
			2	DTF0N	0	Direction of TF0N that affects $\overline{\text{FAULT}}$ pin (when not masked). 0: TF0N=1 will cause $\overline{\text{FAULT}}$ to be 0 (when the condition is not masked off). 1: TF0N=0 will cause $\overline{\text{FAULT}}$ to be 0 (when the condition is not masked off).
			1	DTF0P	0	Direction of TF0P that affects $\overline{\text{FAULT}}$ pin (when not masked). 0: TF0P=1 will cause $\overline{\text{FAULT}}$ to be 0 (when the condition is not masked off). 1: TF0P=0 will cause $\overline{\text{FAULT}}$ to be 0 (when the condition is not masked off).
			0	DLOS	0	Direction of $\overline{\text{LOS}}$ that affects $\overline{\text{FAULT}}$ pin (when not masked). 0: $\overline{\text{LOS}}$ =0 will cause $\overline{\text{FAULT}}$ to be 0 (when the condition is not masked off). 1: $\overline{\text{LOS}}$ =1 will cause $\overline{\text{FAULT}}$ to be 0 (when the condition is not masked off).
04h	R/W	OUTPUT0	7:5	HDTF0Thresh	100	Sets the Termination Fault threshold for SDO0, when SD is set to HD rates (0). Combines with HDTF0ThreshLSB in register 03h (default for combined value is 1001).
			4:0	AMP0	10000	SDO0 output amplitude in roughly 5 mV steps.

Address	R/W	Name	Bits	Field	Default	Description
05h	R/W	OUTPUT0CTRL	7	RSVD	0	Reserved as 0. Always write 0 to this bit.
			6	FLOSOFF	0	Force $\overline{\text{LOS}}$ to always OFF in regard to its effect on the output signal. This forces the device into either the mute or “add offset” state. The $\overline{\text{LOS}}$ bit in register 01h still reflects the correct state of $\overline{\text{LOS}}$. 0: $\overline{\text{LOS}}$ operates normally, muting or adding offset as specified by the MUTE bit. 1: Muting or adding offset is always in place as specified by the MUTE bit.
			5	FLOSON	0	Force $\overline{\text{LOS}}$ to always ON in regard to its effect on the output signal. This prevents the device from muting or adding offset. The $\overline{\text{LOS}}$ bit in register 01h still reflects the correct state of $\overline{\text{LOS}}$. 0: $\overline{\text{LOS}}$ operates normally, muting or adding offset as specified in the MUTE bit. 1: Muting or adding offset never occurs.
			4	LOSEN	0	Configures $\overline{\text{LOS}}$ to be combined with the ENABLE functionality. 0: Only the PD bits and ENABLE pin affect the power down state of the output drivers. 1: If the ENABLE pin is set to ground, it powers down the output drivers regardless of the state of $\overline{\text{LOS}}$ or the PD bits. With the ENABLE pin set to V_{CC} , $\overline{\text{LOS}}=0$ will power down the output drivers, and $\overline{\text{LOS}}=1$ will leave the power down state dependent on the PD bits.
			3	MUTE	0	Selects whether the device will MUTE when loss of signal is detected or add an offset to prevent self oscillation. When an input signal is detected ($\overline{\text{LOS}}=1$), the device will operate normally. 0: Loss of signal will force a small offset to prevent self oscillation. 1: Loss of signal will force the channel to MUTE.
			2:0	SDTF0Thresh	010	Sets the Termination Fault threshold for SDO0, when SD is set to SD rates (1). Combines with SDTF0ThreshLSB in register 03h (default for combined value is 0101).
06h	R/W	OUTPUT1	7:5	HDTF1Thresh	100	Sets the Termination Fault threshold for SDO1, when SD is set to HD rates (0). Combines with HDTF1ThreshLSB in register 07h (default for combined value is 1001).
			4:0	AMP1	10000	SDO1 output amplitude in roughly 5 mV steps.
07h	R/W	OUTPUT1CTRL	7	HDTF1ThreshLSB	1	Least Significant Bit for HDTF1Thresh detection threshold. Combines with HDTF1Thresh bits in register 06h.
			6	SDTF1ThreshLSB	1	Least Significant Bit for SDTF1Thresh detection threshold. Combines with SDTF1Thresh bits in register 07h.
			5:3	RSVD	011	Reserved as 011. Always write 011 to these bits.
			2:0	SDTF1Thresh	010	Sets the Termination Fault threshold for SDO1, when SD is set to SD rates (1). Combines with SDTF1ThreshLSB in bit 6 (default for combined value is 0101).

Address	R/W	Name	Bits	Field	Default	Description
08h	R/W	TEST	7:5	CMPCMD	000	Compare command. Determines whether the peak value or the current value of the Termination Fault counters is read in registers 0Ah-0Dh. 000: Resets compare value to 00; registers 0Ah-0Dh all show current counter values. Sets detection to look for MAX peak values. 001: Capture counter 0. Register 0Ah shows peak value. 010: Capture counter 1. Register 0Bh shows peak value. 011: Capture counter 2. Register 0Ch shows peak value. 100: Capture counter 3. Register 0Dh shows peak value. 101: Resets compare value to 1Fh. Sets detection to look for MIN peak values. 110, 111: Reserved.
			4:0	RSVD	00000	Reserved as 00000. Always write 00000 to these bits.
09h	R	REV	7:5	RSVD	000	Reserved.
			4:3	DIEREV	10	Die Revision.
			2:0	PARTID	010	Part Identifier. Note that single output devices (LMH0303) have the LSB=1. Dual output devices (LMH0307) have the LSB=0.
0Ah	R	TF0PCOUNT	7:5	RSVD	000	Reserved.
			4:0	TF0PCOUNT	00000	This is either the current value of TF0P Counter, or the peak value of the counter, depending on CMPCMD in register 08h.
0Bh	R	TF0NCOUNT	7:5	RSVD	000	Reserved.
			4:0	TF0NCOUNT	00000	This is either the current value of TF0N Counter, or the peak value of the counter, depending on CMPCMD in register 08h.
0Ch	R	TF1PCOUNT	7:5	RSVD	000	Reserved.
			4:0	TF1PCOUNT	00000	This is either the current value of TF1P Counter, or the peak value of the counter, depending on CMPCMD in register 08h.
0Dh	R	TF1NCOUNT	7:5	RSVD	000	Reserved.
			4:0	TF1NCOUNT	00000	This is either the current value of TF1N Counter, or the peak value of the counter, depending on CMPCMD in register 08h.

Physical Dimensions inches (millimeters) unless otherwise noted

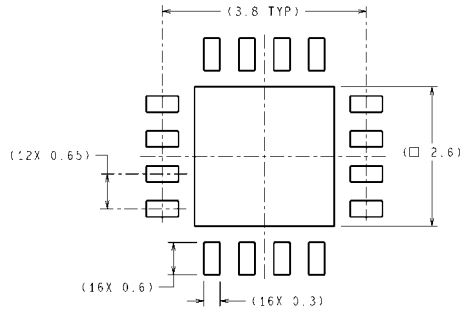

RECOMMENDED LAND PATTERN

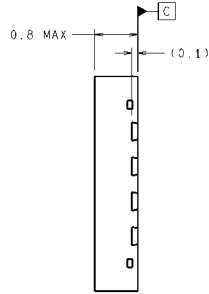
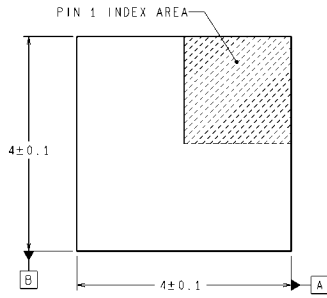

DIMENSIONS ARE IN MILLIMETERS
DIMENSIONS IN () FOR REFERENCE ONLY

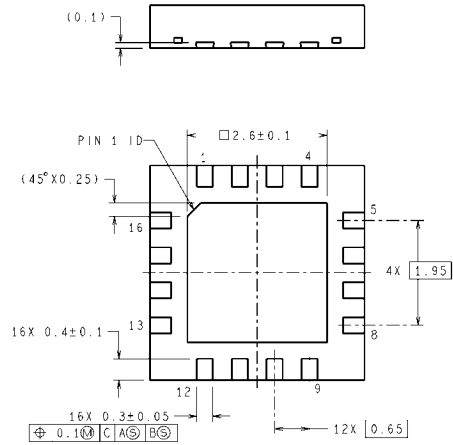

SQB16A (Rev A)

16-Pin LLP
Order Number LMH0307SQ
NS Package Number SQB16A

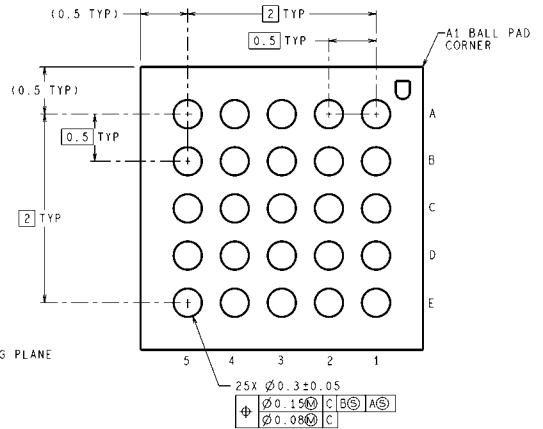
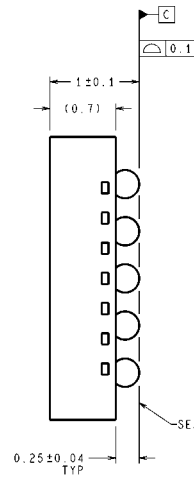
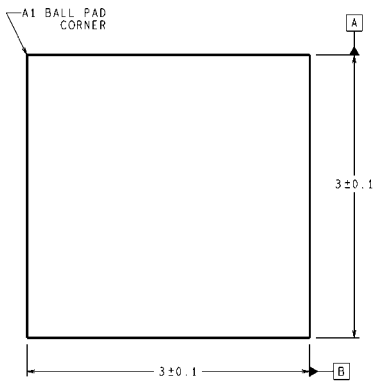

DIMENSIONS ARE IN MILLIMETERS
DIMENSIONS IN () FOR REFERENCE ONLY

GRA25A (Rev A)

25-Ball MICRO-ARRAY
Order Number LMH0307GR
NS Package Number GRA25A

Notes

LMH0307

Notes

For more National Semiconductor product information and proven design tools, visit the following Web sites at:

Products		Design Support	
Amplifiers	www.national.com/amplifiers	WEBENCH® Tools	www.national.com/webench
Audio	www.national.com/audio	App Notes	www.national.com/appnotes
Clock and Timing	www.national.com/timing	Reference Designs	www.national.com/refdesigns
Data Converters	www.national.com/adc	Samples	www.national.com/samples
Interface	www.national.com/interface	Eval Boards	www.national.com/evalboards
LVDS	www.national.com/lvds	Packaging	www.national.com/packaging
Power Management	www.national.com/power	Green Compliance	www.national.com/quality/green
Switching Regulators	www.national.com/switchers	Distributors	www.national.com/contacts
LDOs	www.national.com/ldo	Quality and Reliability	www.national.com/quality
LED Lighting	www.national.com/led	Feedback/Support	www.national.com/feedback
Voltage Reference	www.national.com/vref	Design Made Easy	www.national.com/easy
PowerWise® Solutions	www.national.com/powerwise	Solutions	www.national.com/solutions
Serial Digital Interface (SDI)	www.national.com/sdi	Mil/Aero	www.national.com/milaero
Temperature Sensors	www.national.com/tempsensors	Solar Magic®	www.national.com/solarmagic
Wireless (PLL/VCO)	www.national.com/wireless	Analog University®	www.national.com/AU

THE CONTENTS OF THIS DOCUMENT ARE PROVIDED IN CONNECTION WITH NATIONAL SEMICONDUCTOR CORPORATION ("NATIONAL") PRODUCTS. NATIONAL MAKES NO REPRESENTATIONS OR WARRANTIES WITH RESPECT TO THE ACCURACY OR COMPLETENESS OF THE CONTENTS OF THIS PUBLICATION AND RESERVES THE RIGHT TO MAKE CHANGES TO SPECIFICATIONS AND PRODUCT DESCRIPTIONS AT ANY TIME WITHOUT NOTICE. NO LICENSE, WHETHER EXPRESS, IMPLIED, ARISING BY ESTOPPEL OR OTHERWISE, TO ANY INTELLECTUAL PROPERTY RIGHTS IS GRANTED BY THIS DOCUMENT.

TESTING AND OTHER QUALITY CONTROLS ARE USED TO THE EXTENT NATIONAL DEEMS NECESSARY TO SUPPORT NATIONAL'S PRODUCT WARRANTY. EXCEPT WHERE MANDATED BY GOVERNMENT REQUIREMENTS, TESTING OF ALL PARAMETERS OF EACH PRODUCT IS NOT NECESSARILY PERFORMED. NATIONAL ASSUMES NO LIABILITY FOR APPLICATIONS ASSISTANCE OR BUYER PRODUCT DESIGN. BUYERS ARE RESPONSIBLE FOR THEIR PRODUCTS AND APPLICATIONS USING NATIONAL COMPONENTS. PRIOR TO USING OR DISTRIBUTING ANY PRODUCTS THAT INCLUDE NATIONAL COMPONENTS, BUYERS SHOULD PROVIDE ADEQUATE DESIGN, TESTING AND OPERATING SAFEGUARDS.

EXCEPT AS PROVIDED IN NATIONAL'S TERMS AND CONDITIONS OF SALE FOR SUCH PRODUCTS, NATIONAL ASSUMES NO LIABILITY WHATSOEVER, AND NATIONAL DISCLAIMS ANY EXPRESS OR IMPLIED WARRANTY RELATING TO THE SALE AND/OR USE OF NATIONAL PRODUCTS INCLUDING LIABILITY OR WARRANTIES RELATING TO FITNESS FOR A PARTICULAR PURPOSE, MERCHANTABILITY, OR INFRINGEMENT OF ANY PATENT, COPYRIGHT OR OTHER INTELLECTUAL PROPERTY RIGHT.

LIFE SUPPORT POLICY

NATIONAL'S PRODUCTS ARE NOT AUTHORIZED FOR USE AS CRITICAL COMPONENTS IN LIFE SUPPORT DEVICES OR SYSTEMS WITHOUT THE EXPRESS PRIOR WRITTEN APPROVAL OF THE CHIEF EXECUTIVE OFFICER AND GENERAL COUNSEL OF NATIONAL SEMICONDUCTOR CORPORATION. As used herein:

Life support devices or systems are devices which (a) are intended for surgical implant into the body, or (b) support or sustain life and whose failure to perform when properly used in accordance with instructions for use provided in the labeling can be reasonably expected to result in a significant injury to the user. A critical component is any component in a life support device or system whose failure to perform can be reasonably expected to cause the failure of the life support device or system or to affect its safety or effectiveness.

National Semiconductor and the National Semiconductor logo are registered trademarks of National Semiconductor Corporation. All other brand or product names may be trademarks or registered trademarks of their respective holders.

Copyright© 2009 National Semiconductor Corporation

For the most current product information visit us at www.national.com



**National Semiconductor
Americas Technical
Support Center**
Email: support@nsc.com
Tel: 1-800-272-9959

**National Semiconductor Europe
Technical Support Center**
Email: europe.support@nsc.com
German Tel: +49 (0) 180 5010 771
English Tel: +44 (0) 870 850 4288

**National Semiconductor Asia
Pacific Technical Support Center**
Email: ap.support@nsc.com

**National Semiconductor Japan
Technical Support Center**
Email: jpn.feedback@nsc.com