

LM95172Q

Digital Temperature Sensor in Die Form with $\pm 1^\circ\text{C}$ Accuracy from 130°C to 160°C

General Description

The LM95172Q is a digital temperature sensor with industry-leading accuracy at temperatures up to 175°C . It features a linear Sigma-Delta Analog-to-Digital Converter (ADC) with fast conversion rates and low output noise. Communication with the LM95172Q is achieved over an easy-to-use Serial Peripheral Interface (SPI) with high noise immunity.

The LM95172Q's resolution is user programmable from 0.0625°C to 0.0078125°C . When operating in 13-, 14- or 15-bit resolution, the LM95172Q indicates a new conversion has been completed. The LM95172Q also features an over-temperature alarm output (OVERTEMP) that asserts when the die temperature exceeds a programmed high limit.

The LM95172Q is specified for operation over the wide temperature range of -40°C to 175°C . It is available in die form which makes the LM95172Q ideal multi-chip modules or custom packaging to a wide variety of high-temperature applications.

Applications

- Automotive
- Process Monitoring
- Harsh-environment temperature monitoring
- Custom-package applications
- High-Temperature Modules

Features

- AEC-Q100 Grade 0 qualified and is manufactured on an Automotive Grade Flow.
- 0.0625°C to 0.0078125°C temperature resolution
- Wide -40°C to $+175^\circ\text{C}$ temperature range
- 35 ms conversion time tracks fast temp changes
- OVERTEMP digital output switches when $T_{\text{DIE}} > T_{\text{HIGH}}$
- Shutdown mode saves power yet wakes up for one-shot temperature update

Key Specifications

■ Analog and Digital Supply Voltage	3.0V to 5.5V
■ Total Supply Current	Operating 400 μA (typ)
Shutdown -40°C to $+140^\circ\text{C}$	4 μA (max)
Shutdown -40°C to $+175^\circ\text{C}$	12 μA (max)
■ Temperature Accuracy	
+130°C to +160°C	$\pm 1.0^\circ\text{C}$ (max)
+120°C to +130°C	$\pm 2.0^\circ\text{C}$ (max)
+160°C to +175°C	$\pm 2.0^\circ\text{C}$ (max)
-40°C to $+120^\circ\text{C}$	$\pm 3.5^\circ\text{C}$ (max)
■ Temperature Resolution	
13-bit mode	$0.0625^\circ\text{C}/\text{LSB}$
16-bit mode	$0.0078125^\circ\text{C}/\text{LSB}$
■ Conversion Time	
13-bit mode	35 ms (max)
16-bit mode	280 ms (max)

Simplified Block Diagram (Die Form)

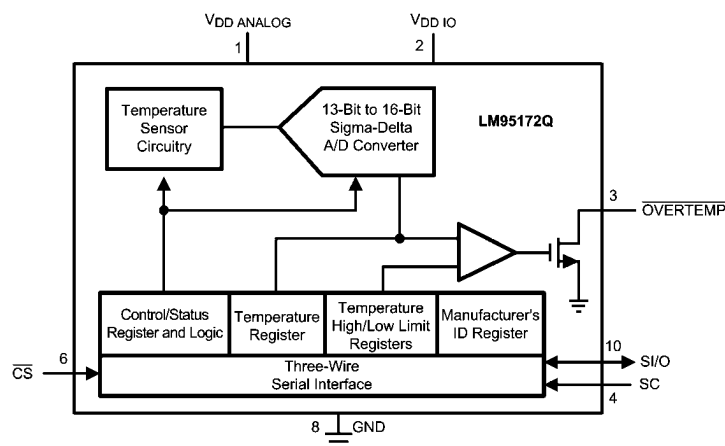

30035701

MICROWIRE® is a registered trademark of National Semiconductor Corporation.
 TRI-STATE® is a registered trademark of National Semiconductor Corporation.

Connection Diagram

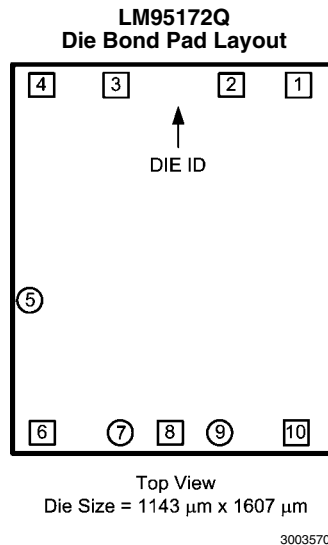

Bond Pad Mechanical Dimensions

Origin of coordinates: center of die. Coordinates refer to center of Bond Pad. X-Direction is in the longitudinal axis of the die. Opening Sizes (Pads 1-4, 6, 8, and 10) = 69.2 μm x 69.2 μm . No Connect = Do not connect to this pad. Manufacturer's test pad.

Pad Number	X Coordinate (μm)	Y Coordinate (μm)
1	497.75	728.80
2	242.80	728.80
3	-147.35	728.80
4	-497.75	728.80
5	No Connect	No Connect
6	-497.75	-728.80
7	No Connect	No Connect
8	0.00	-728.80
9	No Connect	No Connect
10	497.75	-728.80

Pad Descriptions

Pad Number	Name	Type	Description	Typical Connection
1	$V_{\text{DD ANA}}$	Power	Analog Power Supply Voltage	DC Voltage from 3.0V to 5.5V. Bypass with a 10 nF ceramic capacitor near the pad to ground.
2	$V_{\text{DD IO}}$	Power	I/O Power Supply Voltage	DC Voltage from 3.0V to 5.5V. Bypass with a 10 nF ceramic capacitor near the pad to ground.
3	$\overline{\text{OVERTEMP}}$	Output	$\overline{\text{OVERTEMP}}$ Alarm	Over-temperature Alarm Output, Open-drain. Active Low on POR. Requires a pull-up resistor to $V_{\text{DD IO}}$.
4	SC	Input	Serial Clock input	Serial clock from the Controller
5	NC	N/A	No Connect	Do not connect to this pad.
6	$\overline{\text{CS}}$	Input	Chip Select input	Chip Select input for the bus. Low pass filtered. (Note 7)
7	NC	N/A	No Connect	Do not connect to this pad.
8	GND	Ground	Power Supply Ground	Ground
9	NC	N/A	No Connect	Do not connect to this pad.

Pad Number	Name	Type	Description	Typical Connection
10	SI/O	Bidirectional	Serial I/O	Serial I/O Data line to or from the Controller
Backside	BACK	N/A	Substrate connection	May be connected to GND connection.

Ordering Information

Order Number	NS Package Number	Transport Media
LM95172QA2 MDA	Die form. No package.	7000 units in 8 mm Surf Tape

Typical Application

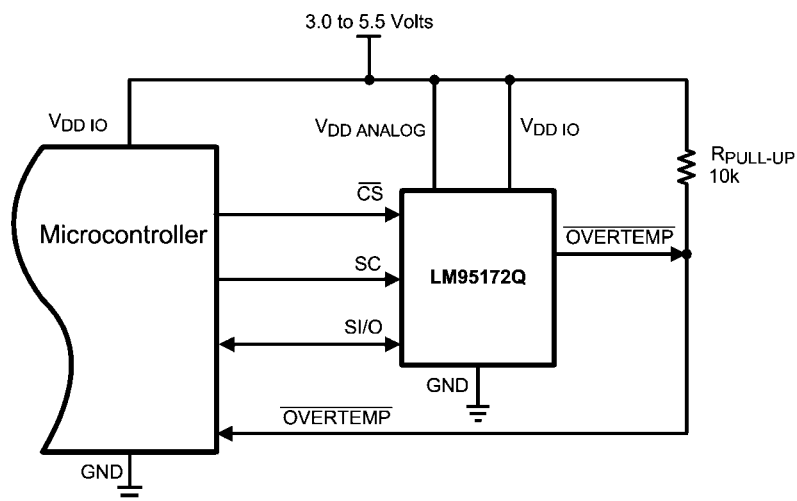

30035703

FIGURE 1. Microcontroller Interface - normal connection

Absolute Maximum Ratings (Note 1)

$V_{DD\ ANALOG}$ and $V_{DD\ IO}$ Supply Voltages	-0.2V to 6.0V
Voltage at any SI/O, SC, and \overline{CS} Pins (Note 7)	-0.2V to ($V_{DD\ IO} + 0.2V$)
Voltage at $\overline{OVERTEMP}$ Pin	-0.3V to 5.5V
Input Current at any Pin (Note 2)	5 mA
Storage Temperature	-65°C to +175°C
ESD Susceptibility (Note 4)	
Human Body Model	2500 V
Machine Model	250 V
Charged Device Model	1000 V

Operating Ratings

Specified Temperature Range LM95172Q (Note 5)	T_{MIN} to T_{MAX} -40°C to +175°C
Analog Supply Voltage Range $V_{DD\ ANALOG}$ (Note 6)	+3.0V to +5.5V
Digital Supply Voltage Range $V_{DD\ IO}$ (Note 6)	+3.0V to +5.5V

Temperature-to-Digital Converter Characteristics

Unless otherwise noted, these specifications apply for $V_{DD\ ANALOG} = V_{DD\ IO} = 3.0V$ to 3.6V. **Boldface limits apply for $T_A = T_J = T_{MIN}$ to T_{MAX}** ; all other limits $T_A = T_J = 25^\circ C$, unless otherwise noted.

Parameter	Conditions	Typical (Note 9)	LM95172Q Limits (Note 10)	Units (Limit)	
Temperature Accuracy (Note 6)	$T_A = +130^\circ C$ to $+160^\circ C$		± 1.0	$^\circ C$ (max)	
	$T_A = +120^\circ C$ to $+130^\circ C$		± 2.0		
	$T_A = +160^\circ C$ to $+175^\circ C$		± 2.0		
	$T_A = -40^\circ C$ to $+120^\circ C$		± 3.5		
Resolution	Res 1 Bit Res 0 Bit 0 0	13 0.0625		Bits $^\circ C$	
	0 1	14 0.03125		Bits $^\circ C$	
	1 0	15 0.015625		Bits $^\circ C$	
	1 1	16 0.0078125		Bits $^\circ C$	
Temperature Conversion Time	For 13 Bits Resolution		35	ms (max)	
	For 14 Bits Resolution		70		
	For 15 Bits Resolution		140		
	For 16 Bits Resolution		280		
Total Quiescent Current (Note 8)	Bus Inactive	$T_A = -40^\circ C$ to $140^\circ C$	400	μA (max)	
	Continuous Conversion Mode	$T_A = -40^\circ C$ to $175^\circ C$			510
		$T_A = -40^\circ C$ to $140^\circ C$	TBD		4
	Shutdown Mode	$T_A = -40^\circ C$ to $175^\circ C$			12
Power-On Reset Threshold	$T_A = -40^\circ C$ to $140^\circ C$		0.9	V (min)	
			2.1	V (max)	
	$T_A = -40^\circ C$ to $175^\circ C$		0.75	V (min)	
			2.1	V (max)	

Logic Electrical Characteristics

Digital DC Characteristics

Unless otherwise noted, these specifications apply for $V_{DD\ ANALOG} = V_{DD\ IO} = 3.0V$ to $3.6V$. (Note 6). **Boldface limits apply for $T_A = T_J = T_{MIN}$ to T_{MAX}** ; all other limits $T_A = T_J = +25^\circ C$, unless otherwise noted.

Symbol	Parameter	Conditions	Typical (Note 9)	Limits (Note 10)	Units (Limit)
V_{IH}	Logical "1" Input Voltage			$0.75 \times V_{DD\ IO}$	V (min)
V_{IL}	Logical "0" Input Voltage			$0.25 \times V_{DD\ IO}$	V (max)
V_{HYST}	Digital Input Hysteresis	$V_{DD\ IO} = 3.0V$	0.63	0.42	V (min)
		$V_{DD\ IO} = 3.3V$	0.79	0.56	
		$V_{DD\ IO} = 3.6V$	0.97	0.72	
I_{IH}	Logical "1" Input Current	$V_{IN} = V_{DD\ IO}$		1	μA (max)
I_{IL}	Logical "0" Input Current	$V_{IN} = 0V$		-1	μA (max)
V_{OH}	Output High Voltage	$I_{OH} = 100\ \mu A$ (Source)		$V_{DD\ IO} - 0.2$	V (min)
		$I_{OH} = 2\ mA$ (Source)		$V_{DD\ IO} - 0.45$	
V_{OL}	Output Low Voltage	$I_{OL} = 100\ \mu A$ (Sink)		0.2	V (max)
		$I_{OL} = 2\ mA$ (Sink)		0.45	
	$\overline{OVERTEMP}$ Output Saturation Voltage	$I_{OL} = 2\ mA$ (Sink)		0.45	V(max)

Serial Bus Digital Switching Characteristics

Unless otherwise noted, these specifications apply for $V_{DD\ ANALOG} = V_{DD\ IO} = 3.0V$ to $3.6V$ (Note 6); C_L (load capacitance) on output lines = $100\ pF$ unless otherwise specified. **Boldface limits apply for $T_A = T_J = T_{MIN}$ to T_{MAX}** ; all other limits $T_A = T_J = +25^\circ C$, unless otherwise noted. See (Note 7) for \overline{CS} voltage restriction.

Symbol	Parameter	Conditions	Typical (Note 9)	Limits (Note 10)	Units (Limit)
t_1	SC (Serial Clock) Period			765	ns (min)
t_2	\overline{CS} (Chip Select) Low to SC High Set-Up Time (Note 13)			1.25	μs (min)
t_3	\overline{CS} Low to SI/O Output Delay (Note 13)			1	μs (max)
t_4	SC Low to SI/O Output Delay			84	ns (max)
t_5	\overline{CS} High to Data Out (SI/O) TRI-STATE			200	ns (max)
t_6	SC High to SI/O Input Hold Time			50	ns (min)
t_7	SI/O Input to SC High Set-Up Time			30	ns (min)
t_8	SC Low to \overline{CS} High Hold Time			50	ns (min)
t_{TA}	Data Turn-Around Time: SI/O input (write to LM95172Q) to output (read from LM95172Q)			94	ns (max)
t_{BUF}	Bus free time between communications: \overline{CS} High to \overline{CS} Low. (Note 13)			5	μs (min)

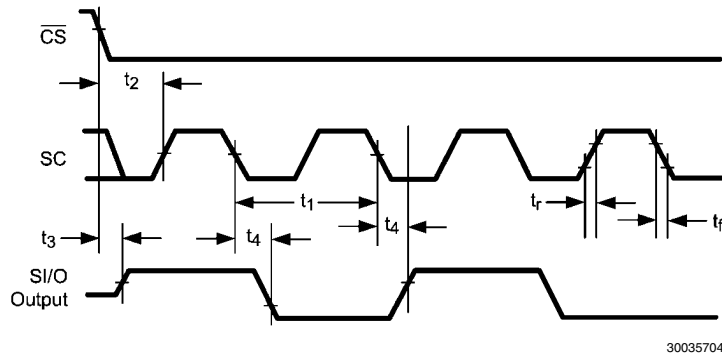

FIGURE 2. Data Output Timing Diagram

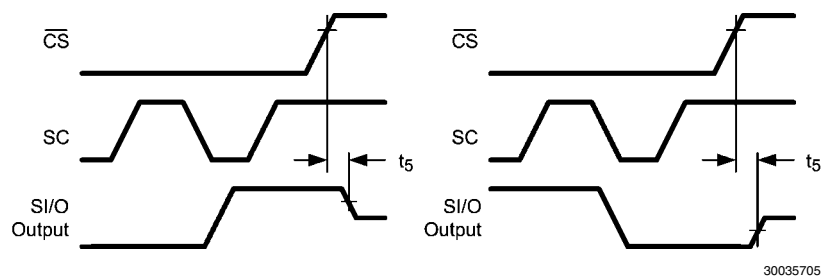

FIGURE 3. TRI-STATE Data Output Timing Diagram

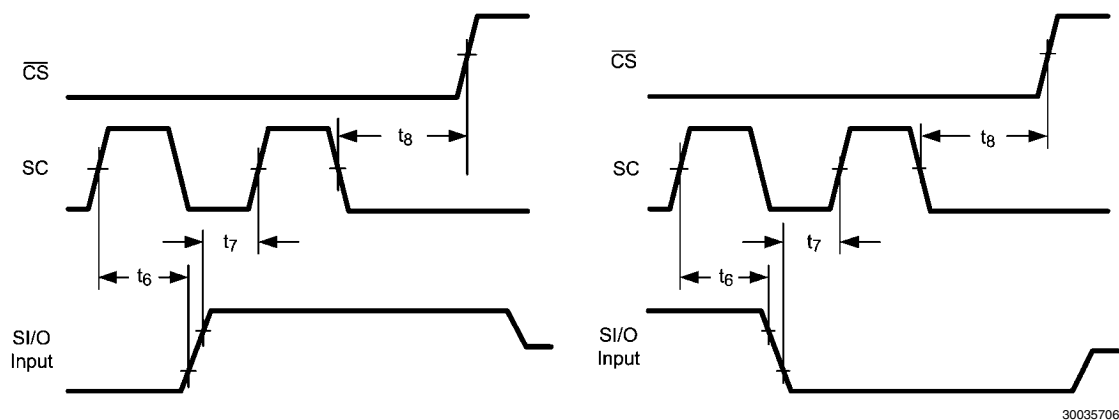
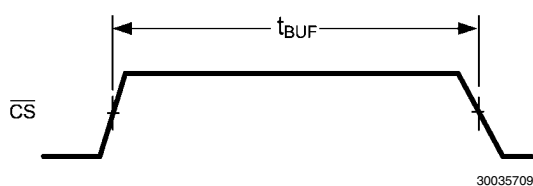
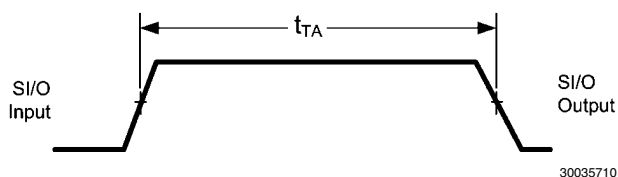

FIGURE 4. Data Input Timing Diagram

FIGURE 5. t_{BUF} Timing Definition DiagramFIGURE 6. t_{TA} Timing Definition Diagram

Note 1: Absolute Maximum Ratings indicate limits beyond which damage to the device may occur. DC and AC electrical specifications do not apply when operating the device beyond its rated operating conditions.

Note 2: When the input voltage (V_I) at any pad exceeds the power supplies ($V_I < \text{GND}$ or $V_I > [V_{DD\text{ ANALOG}}$ or $V_{DD\text{ IO}}]$) the current at that pad should be limited to 5 mA.

Note 3: Invalid. The LM95172Q will return a "0" if read. If written to, no valid register will be modified.

Note 4: Human body model, 100 pF discharged through a 1.5 k Ω resistor. Machine model, 200 pF discharged directly into each pad. The Charged Device Model (CDM) is a specified circuit characterizing an ESD event that occurs when a device acquires charge through some triboelectric (frictional) or electrostatic induction processes and then abruptly touches a grounded object or surface.

Note 5: The LM95172Q is specified for continuous operation at 150°C with occasional short-term excursions to 175°C.

Note 6: The LM95172Q will operate properly over the $V_{DD\text{ ANALOG}} = 3.0\text{V}$ to 5.5V and $V_{DD\text{ IO}} = 3.0\text{V}$ to 5.5V supply voltage ranges.

Note 7: The voltage on the Chip Select ($\overline{\text{CS}}$) pad must be less than or equal to ($V_{DD\text{ IO}} + 0.2\text{V}$) at all times. $V_{DD\text{ IO}}$ must be fully powered-up before $\overline{\text{CS}}$ is allowed to go high.

Note 8: Total Quiescent Current includes the sum of the currents into the $V_{DD\text{ ANALOG}}$ and the $V_{DD\text{ IO}}$ pads.

Note 9: Typicals are at $T_A = 25^\circ\text{C}$ and represent most likely parametric norm.

Note 10: Limits are guaranteed to National's AOQL (Average Outgoing Quality Level).

Note 11: This specification is provided only to indicate how often temperature data is updated. The LM95172Q can be read at any time without regard to conversion state (and will yield last conversion result). A conversion in progress will not be interrupted. The output shift register will be updated at the completion of the read and a new conversion restarted.

Note 12: For best accuracy, minimize output loading. Higher sink currents can affect sensor accuracy with internal heating.

Note 13: Guaranteed by design.

TRI-STATE Test Circuit

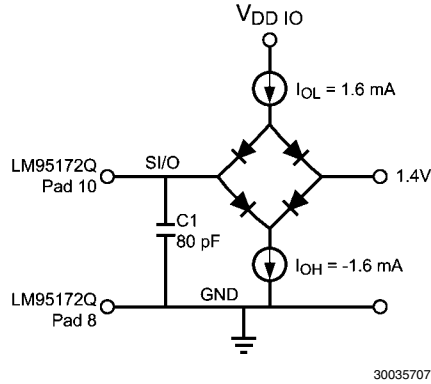
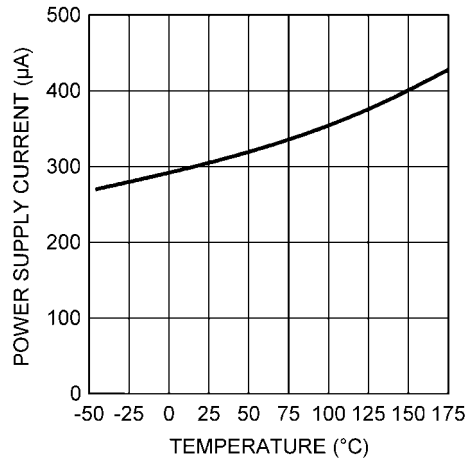

FIGURE 7.

Typical Performance Characteristics

Steady State Power Supply Current vs Temperature



30035796

Temperature Error vs Temperature

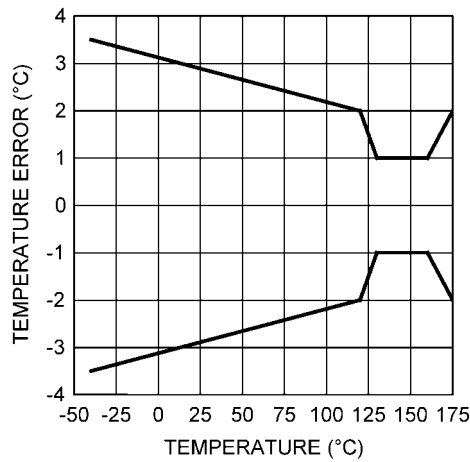

30035797

1.0 Functional Description

The LM95172Q incorporates a temperature sensor and a 13-bit to 16-bit $\Sigma\Delta$ ADC (Sigma-Delta Analog-to-Digital Converter). Compatibility of the LM95172Q's three-wire serial inter-

face with SPI and MICROWIRE allows simple communications with common microcontrollers and processors. Shutdown mode minimizes current drain for different applications. See Figure 8 for the Functional Block Diagram.

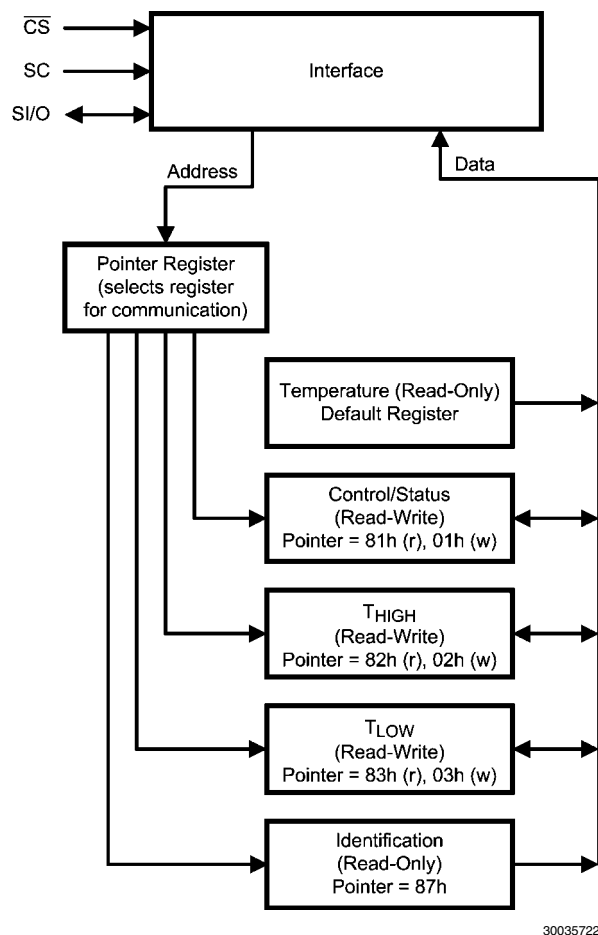

FIGURE 8. LM95172Q Functional Block Diagram

1.1 INITIAL SOFTWARE RESET AND POWER-UP SEQUENCES AND POWER ON RESET (POR)

1.1.1 Software Reset Sequence

A software reset sequence must be followed, after the initial $V_{DD\ ANALOG}$ and $V_{DD\ IO}$ supply voltages reach their specified minimum operating voltages, in order to ensure proper operation of the LM95172Q.

The software reset sequence is as follows:

1. Allow $V_{DD\ ANALOG}$ and $V_{DD\ IO}$ to reach their specified minimum operating voltages, as specified in the Operating Ratings section, and in a manner as specified in section 1.1.2 below.
2. Write a "1" to the Shutdown bit, Bit 15 of the Control/Status Register, and hold it high for at least the specified maximum conversion time for the initial default of 13-bits resolution, in order to ensure that a complete reset operation has occurred. (See the Temperature Conversion Time specifications within the Temperature-to-Digital Characteristics section.)
3. Write a "0" to the Shutdown bit to restore the LM95172Q to normal mode.
4. Wait for at least the specified maximum conversion time for the initial default of 13-bits resolution in order to ensure that accurate data appears in the Temperature Register.

1.1.2 Power-Up Sequence

A. Linear Power-up

In the case where the $V_{DD\ ANALOG}$ and $V_{DD\ IO}$ voltage-vs.-time function is linear, the specified minimum operating voltage must be reached in 5 ms or less.

B. Resistor-Capacitor (R-C) Charging Exponential Power-up

In the case where the $V_{DD\ ANALOG}$ and $V_{DD\ IO}$ voltage-vs.-time function is as a typical R-C Charging exponential function the time constant must be less than or equal to 1.25 ms.

C. Other Power-up Functions

In the case where the $V_{DD\ ANALOG}$ and $V_{DD\ IO}$ voltage-vs.-time characteristic follows another function the following requirements must be met:

- (1) The specified minimum operating voltage values for $V_{DD\ ANALOG}$ and $V_{DD\ IO}$ must be reached in 5 ms or less.
- (2) The slope of the $V_{DD\ ANALOG}$ and $V_{DD\ IO}$ power-up curves must be greater than or equal to 0.7 V/ms at any time before the specified minimum operating voltage is reached.
- (3) The slope of the $V_{DD\ ANALOG}$ and $V_{DD\ IO}$ power-up curves must not allow ringing such that the voltage is allowed to drop below the specified minimum operating voltage at any time after the specified minimum operating voltage is reached.

1.1.3 Power On Reset (POR)

After the requirements of section 1.1.1 and 1.1.2 above are met each register will then contain its defined POR default value. Any of the following actions may cause register values to change from their POR value:

1. The master writes different data to any Read/Write (R/W) bits, or
2. The LM95172Q is powered down.

The specific POR Value of each register is listed in Section 1.7 under Internal Register Structure.

1.2 ONE SHOT CONVERSION

The LM95172Q features a one-shot conversion bit, which is used to initiate a single conversion and comparison cycle when the LM95172Q is in shutdown mode. While the LM95172Q is in shutdown mode, writing a "1" to the One-Shot bit in the Control/Status Register will cause the LM95172Q to perform a single temperature conversion and update the Temperature Register and the affected status bits. Operating the LM95172Q in this one-shot mode allows for extremely low average-power consumption, making it ideal for low-power applications.

When the One-shot bit is set, the LM95172Q initiates a temperature conversion. After this initiation, but before the completion of the conversion, and resultant register updates, the LM95172Q is in a "one-shot" state. During this state, the Data Available (DAV) flag in the Control/Status Register is "0" and the Temperature Register contains the value 8000h (-256°C).

All other registers contain the data that was present before initiating the one-shot conversion. After the temperature measurement is complete, the DAV flag will be set to "1" and the temperature register will contain the resultant measured temperature.

1.3 OVERTEMP OUTPUT

The Over-temperature ($\overline{\text{OVERTEMP}}$) output is a temperature switch signal that indicates when the measured temperature exceeds the T_{HIGH} programmed limit. The programmable T_{HIGH} register sets the high temperature limit and the T_{LOW} register is used to set the hysteresis. The T_{LOW} register also sets the temperature below which the $\overline{\text{OVERTEMP}}$ output resets. The $\overline{\text{OVERTEMP}}$ output of the LM95172Q behaves as a temperature comparator. The following explains the operation of $\overline{\text{OVERTEMP}}$. Figure 9 illustrates the $\overline{\text{OVERTEMP}}$ output behavior.

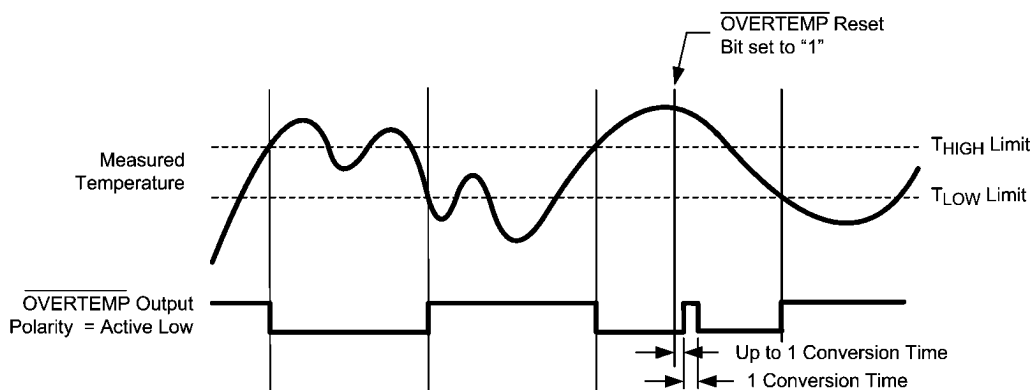

NOTE: The $\overline{\text{OVERTEMP}}$ output asserts when the measured temperature is *greater than* the T_{HIGH} value.

30035721

FIGURE 9. LM95172Q $\overline{\text{OVERTEMP}}$ vs. Temperature Response Diagram

The $\overline{\text{OVERTEMP}}$ Output will assert when the measured temperature is greater than the T_{HIGH} value. $\overline{\text{OVERTEMP}}$ will reset if any of the following events happens:

1. The temperature falls below the value stored in the T_{LOW} register, or
2. A "1" is written to the $\overline{\text{OVERTEMP}}$ Reset bit in the Control/Status Register.

If $\overline{\text{OVERTEMP}}$ is cleared by the master writing a "1" to the $\overline{\text{OVERTEMP}}$ Reset bit while the measured temperature still exceeds the T_{HIGH} value, $\overline{\text{OVERTEMP}}$ will assert again after the completion of the next temperature conversion. Placing the LM95172Q in shutdown mode or triggering a one-shot conversion does not cause $\overline{\text{OVERTEMP}}$ to reset.

1.4 COMMUNICATING WITH THE LM95172Q

The serial interface consists of three lines: \overline{CS} (Chip Select), SC (Serial Clock), and the bi-directional SI/O (Serial I/O) data line. See (Note 7) for \overline{CS} voltage restriction. A high-to-low transition of the \overline{CS} line initiates the communication. The master (processor) always drives the chip select and the clock. The first 16 clocks shift the temperature data out of the LM95172Q on the SI/O line (a temperature read). Raising the \overline{CS} at anytime during the communication will terminate this read operation. Following this temperature read, the SI/O line becomes an input and a command byte can be written to the

LM95172Q. This command byte contains a R/W bit and the address of the register to be communicated with next (see Section 1.7 Internal Register Structure). When writing, the data is latched in after every 8 bits. The processor must write at least 8 bits in order to latch the data. If \overline{CS} is raised before the falling edge of the 8th command bit, no data will be latched into the command byte. If \overline{CS} is raised after the 8th data-register write bit, but before the 16th bit, only the most significant byte of the data will be latched. This command-data-command-data sequence may be performed as many times as desired.

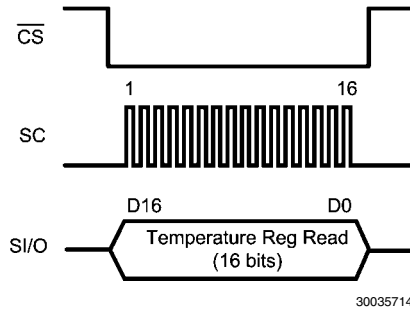

FIGURE 10. Reading the Temperature Register

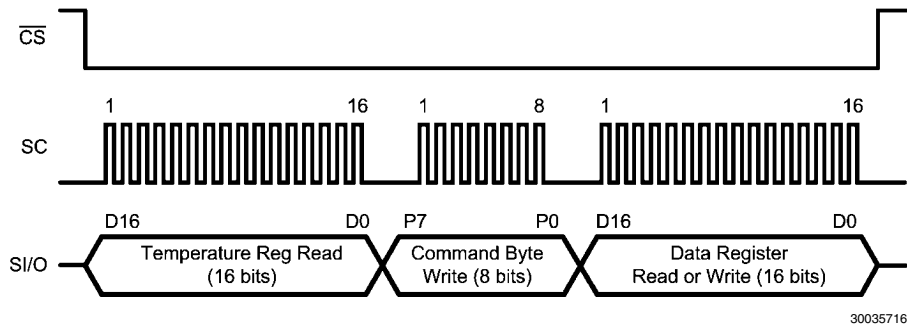

FIGURE 11. Reading the Temperature Register followed by a read or write from another register (Control/Status, T_{HIGH} , T_{LOW} , or Identification register)

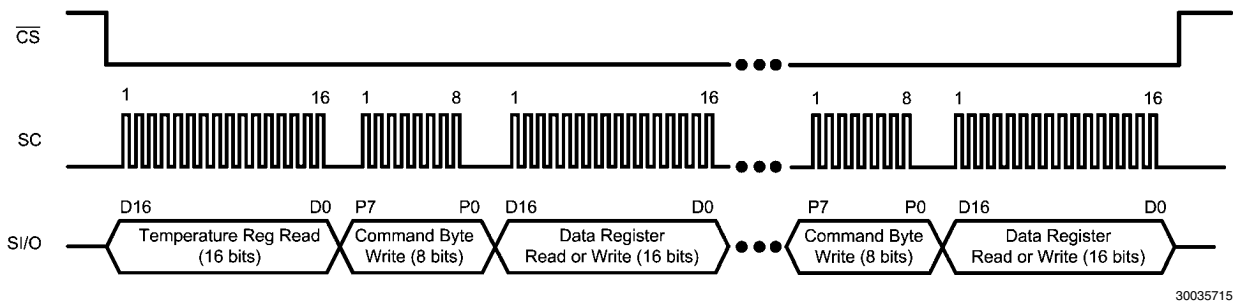

FIGURE 12. Reading the Temperature Register followed by repeated commands and Data Register accesses (Control/Status, T_{HIGH} , T_{LOW} , or Identification register)

1.5 TEMPERATURE DATA FORMAT

Temperature data is represented by a 13- to 16-bit, two's complement word with a Least Significant Bit (LSB) equal to

0.0625 °C (13-bits), 0.03125 °C (14-bits), 0.015625 °C (15-bits) or 0.0078125 °C (16-bits). See Section 1.7.2 for definition of the bits in the Temperature Register.

13-Bit Resolution. First Bit (D15) is Sign, the last bit (D0) is Toggle and bits D1 and D2 are always 0.

Temperature	13-bit Resolution Digital Output		
	16-bit Binary	All 16 Bits	Bits D15 - D3
		Hex	Hex
+175°C	0101011110000 000	5780	0AF0
	0101011110000 001	5781	
+150°C	0100101100000 000	4B00	0960
	0100101100000 001	4B01	
+80°C	0010100000000 000	2800	0500
	0010100000000 001	2801	
+25°C	0000110010000 000	0C80	0190
	0000110010000 001	0C81	
+0.0625°C	0000000000001 000	0008	0001
	0000000000001 001	0009	
0°C	0000000000000 000	0000	0000
	0000000000000 001	0001	
-0.0625°C	1111111111111 000	FFF8	1FFF
	1111111111111 001	FFF9	
-40°C	1110110000000 000	EC00	1D80
	1110110000000 001	EC01	

14-Bit Resolution. First bit (D15) is Sign, the last bit (D0) is Toggle and bit D1 is always 0.

Temperature	14-bit Resolution Digital Output		
	16-bit Binary	All 16 Bits	Bits D15 - D2
		Hex	Hex
+175°C	01010111100000 00	5780	15E0
	01010111100000 01	5781	
+150°C	01001011000000 00	4B00	12C0
	01001011000000 01	4B01	
+80°C	00101000000000 00	2800	0A00
	00101000000000 01	2801	
+25°C	00001100100000 00	0C80	0320
	00001100100000 01	0C81	
+0.03125°C	00000000000001 00	0004	0001
	00000000000001 01	0005	
0°C	00000000000000 00	0000	0000
	00000000000000 01	0001	
-0.03125°C	11111111111111 00	FFFC	3FFF
	11111111111111 01	FFFD	
-40°C	11101100000000 00	EC00	3B00
	11101100000000 01	EC01	

15-Bit Resolution. First bit (D15) is Sign and the last bit (D0) is Toggle.

Temperature	15-bit Resolution Digital Output		
	16-bit Binary	All 16 Bits	Bits D15 - D1
		Hex	Hex
+175°C	010101111000000 0	5780	2BC0
	010101111000000 1	5781	
+150°C	010010110000000 0	4B00	2580
	010010110000000 1	4B01	
+80°C	001010000000000 0	2800	1400
	001010000000000 1	2801	
+25°C	000011001000000 0	0C80	0640
	000011001000000 1	0C81	
+0.015625°C	000000000000001 0	0002	0001
	000000000000001 1	0003	
0°C	000000000000000 0	0000	0000
	000000000000000 1	0001	
-0.015625°C	111111111111111 0	FFFE	7FFF
	111111111111111 1	FFFF	
-40°C	111011000000000 0	EC00	7600
	111011000000000 1	EC01	

16-Bit Resolution. First bit (D15) is Sign and the last bit (D0) is the LSB.

Temperature	16-bit Resolution Digital Output	
	16-bit Binary	All 16 Bits
		Hex
+175°C	0101 0111 1000 0000	5780
+150°C	0100 1011 0000 0000	4B00
+80°C	0010 1000 0000 0000	2800
+25°C	0000 1100 1000 0000	0C80
+0.0078125°C	0000 0000 0000 0001	0001
0°C	0000 0000 0000 0000	0000
-0.0078125°C	1111 1111 1111 1111	FFFF
-40°C	1110 1100 0000 0000	EC00

The first data byte is the most significant byte with most significant bit first, permitting only as much data as necessary to be read to determine temperature condition. For instance, if the first four bits of the temperature data indicate an overtemperature condition, the host processor could immediately take action to remedy the excessive temperatures.

1.6 SHUTDOWN MODE

Shutdown Mode is enabled by writing a “1” to the Shutdown Bit, Bit 15 of the Control/Status Register, and holding it high for at least the specified maximum conversion time at the ex-

isting temperature resolution setting. (see Temperature Conversion Time specifications under the Temperature-to-Digital Characteristics section). For example, if the LM95172Q is set for 16-bit resolution before shutdown, then Bit 15 of the Control/Status register must go high and stay high for the specified maximum conversion time for 16-bits resolution.

The LM95172Q will always finish a temperature conversion and update the temperature registers before shutting down.

Writing a “0” to the Shutdown Bit restores the LM95172Q to normal mode.

1.7 INTERNAL REGISTER STRUCTURE

The LM95172Q has four registers that are accessible by issuing a command byte (a R/\overline{W} Bit plus the register address: Control/Status, T_{HIGH} , T_{LOW} , and Identification. Which of these registers will be read or written is determined by the Command Byte. See Section 1.4, "Communicating with the LM95172Q", for a complete description of the serial communication protocol. The following diagram describes the Command Byte and lists the addresses of the various registers. The temperature is read by lowering the \overline{CS} line and then

clocking the data out from the 16-Bit temperature register; all other registers are accessed by writing a Command Byte after reading the temperature.

All registers can be communicated with, either in Continuous Conversion mode or in Shutdown mode. When the LM95172Q has been placed in Shutdown Mode, the Temperature register will contain the temperature data which resulted from the last temperature conversion (whether it was the result of a continuous-conversion reading or a one-shot reading).

1.7.1 Command Byte

P7	P6	P5	P4	P3	P2	P1	P0
R/\overline{W}	0	0	0	0	Register Select		

Bit <7> Read/ \overline{Write} Bit. Tells the LM95172Q if the host will be writing to, or reading from, the register to which this byte is pointing.

Bits <6:3> Not Used. **These Bits must be zero.** If an illegal address is written, the LM95172Q will return 0000h on the subsequent read.

Bits <2:0> Pointer Address Bits. Points to desired register. See table below.

P2	P1	P0	Register
0	0	0	Invalid. (Note 3)
0	0	1	Control/Status
0	1	0	T_{HIGH}
0	1	1	T_{LOW}
1	0	0	Invalid. (Note 3)
1	0	1	
1	1	0	
1	1	1	Identification

Power-On Reset state: 00h

Reset Conditions: Upon Power-on Reset

1.7.2 Temperature Register

(Read Only): Default Register

D15	D14	D13	D12	D11	D10	D9	D8
Sign	128°C	64°C	32°C	16°C	8°C	4°C	2°C

D7	D6	D5	D4	D3	D2	D1	D0
1°C	0.5°C	0.25°C	0.125°C	0.0625°C	0.03125°C	0.015625°C	Conversion - Toggle/ 0.0078125°C

Bit <15:1>: Temperature Data Byte. Represents the temperature that was measured by the most recent temperature conversion in two's complement form. On power-up, this data is invalid until the DAV Bit in the Control/Status Register is high (that is, after completion of the first conversion).

The resolution is user-programmable from 13-Bit resolution (0.0625°C) through 16-Bit resolution (0.0078125°C). The desired resolution is programmed through Bits 4 and 5 of the Control/Status Register. See the description of the Control/Status Register for details on resolution selection.

The Bits not used for a selected resolution are always set to "0" and are not to be considered part of a valid temperature reading. For example, for 14-Bit resolution, Bit <1> is not used and, therefore, it is invalid and is always zero.

Bit <0>: Conversion Toggle or, if 16-Bit resolution has been selected, this is the 16-Bit temperature LSB.

When in 13-Bit, 14-Bit, or 15-Bit resolution mode, this Bit toggles each time the Temperature register is read **if** a conversion has completed since the last read. If conversion has not completed, the value will be the same as the last read.

When in 16-Bit resolution mode, this is the Least Significant Bit of the temperature data.

Reset Conditions: See Sections 1.1.1 through 1.1.3 for reset conditions.

One-Shot State: 8000h (-256°C)

1.7.3 Control/Status Register

(Read/Write) Pointer Address: 81h (Read); 01h (Write)

D15	D14	D13	D12	D11	D10	D9	D8
SD	One-Shot	$\overline{\text{OVERTEMP}}$ Reset	Conversion Toggle	$\overline{\text{OVERTEMP}}$ Status	T _{HIGH}	T _{LOW}	DAV
D7	D6	D5	D4	D3	D2	D1	D0
$\overline{\text{OVERTEMP}}$ Disable	$\overline{\text{OVERTEMP}}$ POL	RES1	RES0	0	reserved	reserved	0

Bit <15>: Shutdown (SD) Bit. Writing a "1" to this bit and holding it high for at least the specified maximum conversion time, at the existing temperature resolution setting, enables the Shutdown Mode. Writing a "0" to this bit restores the LM95172Q to normal mode.

Bit <14>: One-Shot Bit. When in shutdown mode (Bit <15> is "1"), initiates a single temperature conversion and update of the temperature register with new temperature data. Has no effect when in continuous conversion mode (i.e., when Bit <15> is "0"). Always returns a "0" when read.

Bit <13>: $\overline{\text{OVERTEMP}}$ Reset Bit. Writing a "1" to this Bit resets the $\overline{\text{OVERTEMP}}$ Status bit and, after a possible wait up to one temperature conversion time, the $\overline{\text{OVERTEMP}}$ pad. It will always return a "0" when read.

Bit <12>: Conversion Toggle Bit. Toggles each time the Control/Status register is read if a conversion has completed since the last read. If conversion has not been completed, the value will be the same as last read.

Bit <11>: $\overline{\text{OVERTEMP}}$ pad Status Bit. This Bit is "0" when $\overline{\text{OVERTEMP}}$ output is low and "1" when $\overline{\text{OVERTEMP}}$ output is high. The $\overline{\text{OVERTEMP}}$ output is reset under the following conditions: (1) Cleared by writing a "1" to the $\overline{\text{OVERTEMP}}$ Reset Bit (Bit <13>) in this register or (2) Measured temperature falls below the T_{LOW} limit. If the temperature is still above T_{HIGH}, and $\overline{\text{OVERTEMP}}$ Reset is set to "1", then the Bit and the pad clear until the next conversion, at which point the Bit and pad would assert again.

Bit <10>: Temperature High (T_{HIGH}) Flag Bit. This Bit is set to "1" when the measured temperature exceeds the T_{HIGH} limit stored in the programmable T_{HIGH} register. The flag is reset to "0" when both of two conditions are met: (1) temperature no longer exceeds the programmed T_{HIGH} limit **and** (2) upon reading the Control/Status Register. If the temperature no longer exceeds the T_{HIGH} limit, the status Bit remains set until it is read by the master so that the system can check the history of what caused the $\overline{\text{OVERTEMP}}$ to assert.

Bit <9>: Temperature Low (T_{LOW}) Flag Bit. This Bit is set to "1" when the measured temperature falls below the T_{LOW} limit stored in the programmable T_{LOW} register. The flag is reset to "0" when both of two conditions are met: (1) temperature is no longer below the programmed T_{LOW} limit **and** (2) upon reading the Control/Status Register. If the temperature is no longer below, or equal to, the T_{LOW} limit, the status Bit remains set until it is read by the master so that the system can check the history of what caused the $\overline{\text{OVERTEMP}}$ to assert.

Bit <8>: Data Available (DAV) Status Bit. This Bit is "0" when the temperature sensor is in the process of converting a new temperature. It is "1" when the conversion is done. It is reset after each read and goes high again after one temperature conversion is done. In one-shot mode: after initiating a temperature conversion while operating, this status Bit can be monitored to indicate when the conversion is done. After triggering the one-shot conversion, the data in the temperature register is invalid until this Bit is high (i.e., after completion of the first conversion).

Bit <7>: $\overline{\text{OVERTEMP}}$ Disable Bit. When set to "0" the $\overline{\text{OVERTEMP}}$ output is enabled. When set to "1" the $\overline{\text{OVERTEMP}}$ output is disabled. This Bit also controls the $\overline{\text{OVERTEMP}}$ Status Bit (this register, Bit <11>) since that Bit reflects the state of the $\overline{\text{OVERTEMP}}$ pad.

Bit <6>: $\overline{\text{OVERTEMP}}$ Polarity Bit. When set to "1", $\overline{\text{OVERTEMP}}$ is active-high. When "0" it is active-low.

Bit <5:4>: Temperature Resolution Bits. Selects one of four user-programmable temperature data resolutions as indicated in the following table.

Control/Status Register		Resolution	
Bit 5	Bit 4	Bits	°C
0	0	13	0.0625
0	1	14	0.03125
1	0	15	0.015625
1	1	16	0.0078125

Bit <3>: Always write a zero to this Bit.

Bit <2:1>: Reserved Bits. Will return whatever was last written to them. Value is zero on power-up.

Bit <0>: Always write a zero to this Bit.

Reset State: 0000h

Reset Conditions: Upon Power-on Reset.

1.7.4 T_{HIGH}: Upper Limit Register

(Read/Write) Pointer Address: 82h (Read); 02h (Write)

D15	D14	D13	D12	D11	D10	D9	D8
Sign	128°C	64°C	32°C	16°C	8°C	4°C	2°C

D7	D6	D5	D4	D3	D2	D1	D0
1°C	0.5°C	0.25°C	Reserved				

Bit <15:5>: Upper-Limit Temperature byte. If the measured temperature, stored in the temperature register, exceeds this user-programmable temperature limit, the $\overline{\text{OVERTEMP}}$ pad will assert and the T_{HIGH} flag in the Control/Status register will be set to "1".

Bit <4:0>: Reserved. Returns all zeroes when read.

Reset State: 4880h (+145°C)

Reset Conditions: Upon Power-on Reset.

1.7.5 T_{LOW}: Lower Limit Register

(Read/Write) Pointer Address: 83h (Read); 03h (Write)

D15	D14	D13	D12	D11	D10	D9	D8
Sign	128°C	64°C	32°C	16°C	8°C	4°C	2°C

D7	D6	D5	D4	D3	D2	D1	D0
1°C	0.5°C	0.25°C	Reserved				

Bit <15:5>: Lower-Limit Temperature byte. If the measured temperature that is stored in the temperature register falls below this user-programmable temperature limit, the $\overline{\text{OVERTEMP}}$ pad will not assert and the T_{LOW} flag in the Control/Status register will be set to "1".

Bit <4:0>: Reserved. Returns all zeroes when read.

Reset State: 4600h (+140°C)

Reset Conditions: Upon Power-on Reset.

1.7.6 MFGID: Manufacturer, Product, and Step ID Register

(Read Only) Pointer Address: 87h

D15	D14	D13	D12	D11	D10	D9	D8
1	0	0	0	0	0	0	0

D7	D6	D5	D4	D3	D2	D1	D0
0	0	1	1	0	0	0	0

Bit <15:8>: Manufacturer Identification Byte. Always returns 80h to uniquely identify the manufacturer as National Semiconductor Corporation.

Bit <7:4>: Product Identification Nibble. Always returns 30h to uniquely identify this part as the LM95172Q.

Bit <3:0>: Die Revision Nibble. Returns 0h to uniquely identify the revision level as zero.

Reset State: 8030h

Reset Conditions: Upon Power-on Reset.

1.8 NOISE IMMUNITY OF THE SERIAL I/O (S/I/O) AND SERIAL CLOCK (SC) LINES

The LM95172Q's Serial I/O and Serial Clock lines have high noise immunity making it an excellent choice in challenging electromagnetic environments.

Some typical bench tests, taken at room temperature, were done to show the noise immunity in the case of an injected sinewave signal used to simulate an interfering noise signal. Figure 13 below shows the Test Setup used for the bench test. A function generator was used to create the noise signal. In the first test this signal was AC-coupled to the S/I/O line through a 1 nF capacitor. The amplitude of the signal from the generator was adjusted so that the peak-to-peak voltage at the pad was 400 mVpp, the maximum that is compatible with the Absolute Maximum requirements.

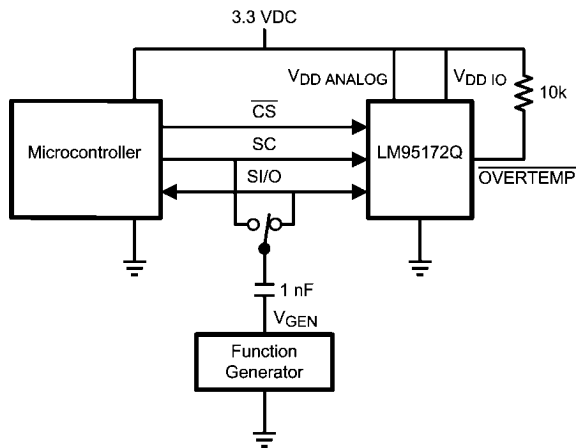

30035711

FIGURE 13. Test Setup for Noise Immunity Test

Figure 14 below shows the combined waveform for the Serial digital and injected noise signals.

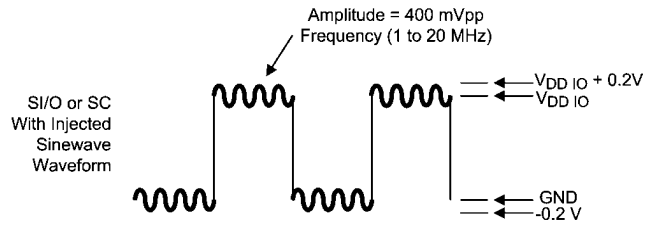

30035712

FIGURE 14. Typical Waveforms for Noise Immunity Test

The LM95172Q's temperature output was read continuously while the noise signal was injected on the serial I/O line. The frequency was increased from 1 to 20 MHz in 1 MHz steps. In the same manner, the Serial Clock (SC) line was tested by injecting a 400 mVpp sinusoidal signal at the serial clock pad and monitoring the continuously reading the LM95172Q temperature.

The Result: **No temperature change** resulted from the interfering signal.

2.0 Typical Applications

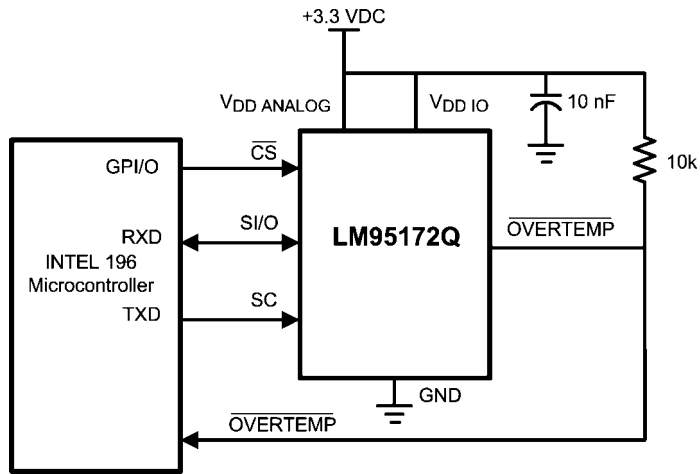

30035720

FIGURE 15. Temperature monitor using Intel 196 processor

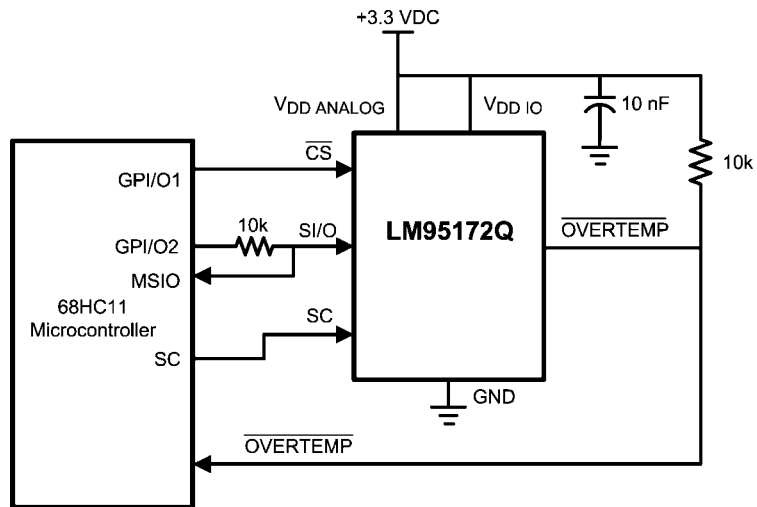

30035719

FIGURE 16. LM95172Q digital input control using microcontroller's general purpose I/O.

Physical Dimensions

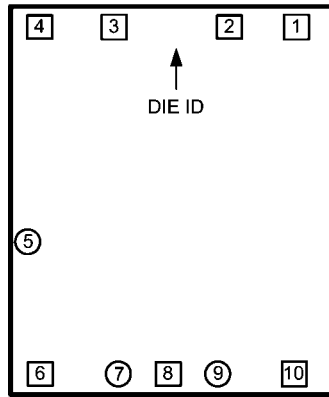

Top View
Die Size = 1143 μm x 1607 μm

Order Number LM95172QA2 MDA ³⁰⁰³⁵⁷⁰²
Die Form

For Bond Pad Mechanical Dimensions, see Connection Diagram Section

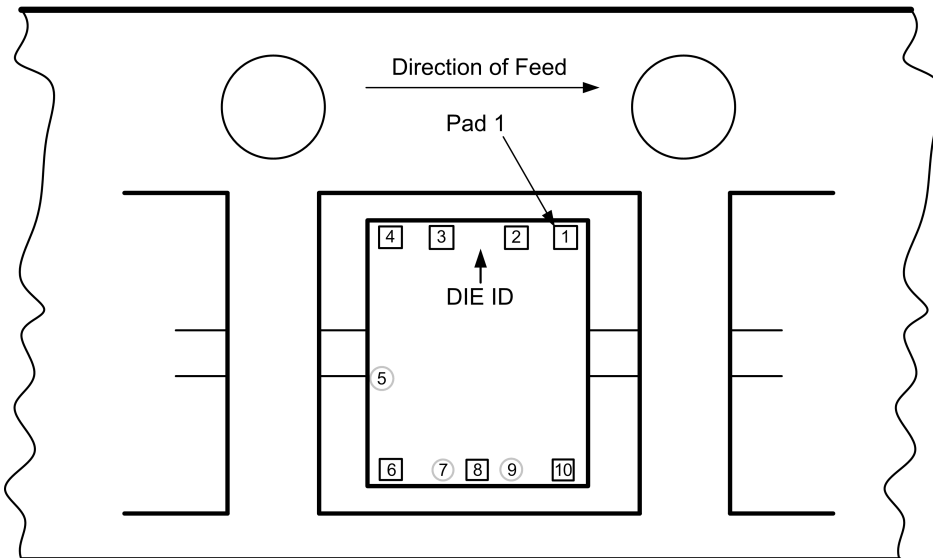

Not To Scale

Orientation of Die in 8 mm Surf Tape

30035723

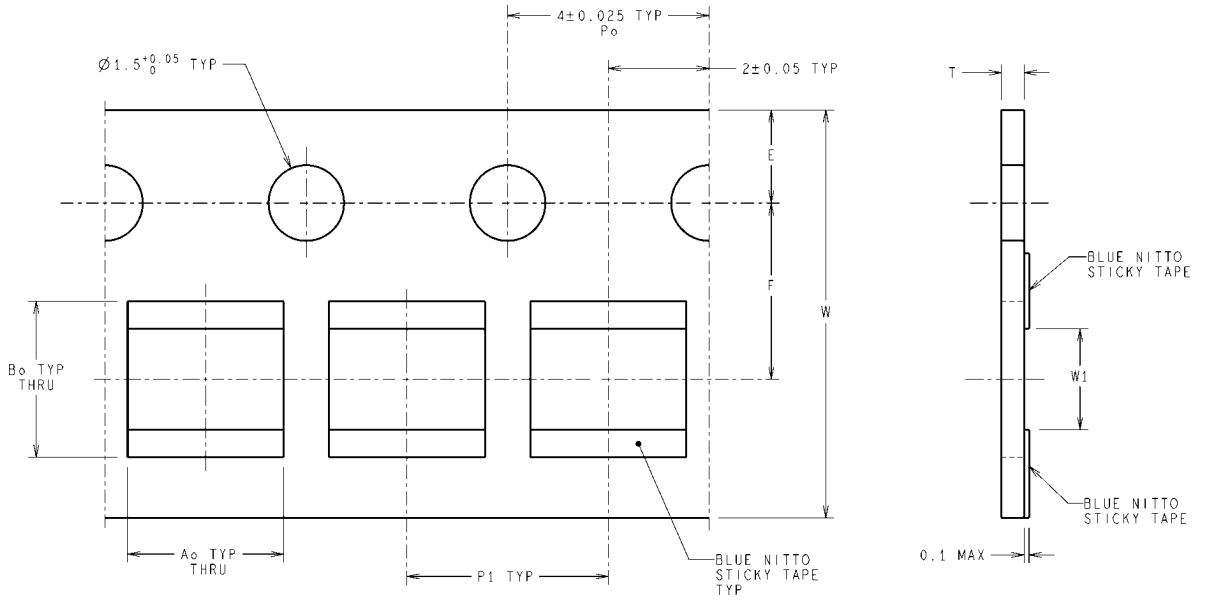

02	070109	6.35 ± 0.10	6.35 ± 0.10	1.75 ± 0.05	5.5 ± 0.05	8 ± 0.1	0.7 ± 0.2	12 ± 0.1	1 ± 0.2
01	070110	3.1 ± 0.1	3.1 ± 0.1	1.75 ± 0.05	3.5 ± 0.05	4 ± 0.1	0.6 ± 0.2	8 ± 0.1	0.4 ± 0.2
OPT	STK #	DIM A_0	DIM B_0	DIM E	DIM F	DIM P_1	DIM T	DIM W	DIM W_1

Dimensions of Surf Tape Transport Media. Use Option 01.

39-2313 (Rev E)

30035799

Notes

LM95172Q

Notes

For more National Semiconductor product information and proven design tools, visit the following Web sites at:

Products		Design Support	
Amplifiers	www.national.com/amplifiers	WEBENCH® Tools	www.national.com/webench
Audio	www.national.com/audio	App Notes	www.national.com/appnotes
Clock and Timing	www.national.com/timing	Reference Designs	www.national.com/refdesigns
Data Converters	www.national.com/adc	Samples	www.national.com/samples
Interface	www.national.com/interface	Eval Boards	www.national.com/evalboards
LVDS	www.national.com/lvds	Packaging	www.national.com/packaging
Power Management	www.national.com/power	Green Compliance	www.national.com/quality/green
Switching Regulators	www.national.com/switchers	Distributors	www.national.com/contacts
LDOs	www.national.com/ldo	Quality and Reliability	www.national.com/quality
LED Lighting	www.national.com/led	Feedback/Support	www.national.com/feedback
Voltage Reference	www.national.com/vref	Design Made Easy	www.national.com/easy
PowerWise® Solutions	www.national.com/powerwise	Solutions	www.national.com/solutions
Serial Digital Interface (SDI)	www.national.com/sdi	Mil/Aero	www.national.com/milaero
Temperature Sensors	www.national.com/tempsensors	SolarMagic™	www.national.com/solarmagic
Wireless (PLL/VCO)	www.national.com/wireless	Analog University®	www.national.com/AU

THE CONTENTS OF THIS DOCUMENT ARE PROVIDED IN CONNECTION WITH NATIONAL SEMICONDUCTOR CORPORATION ("NATIONAL") PRODUCTS. NATIONAL MAKES NO REPRESENTATIONS OR WARRANTIES WITH RESPECT TO THE ACCURACY OR COMPLETENESS OF THE CONTENTS OF THIS PUBLICATION AND RESERVES THE RIGHT TO MAKE CHANGES TO SPECIFICATIONS AND PRODUCT DESCRIPTIONS AT ANY TIME WITHOUT NOTICE. NO LICENSE, WHETHER EXPRESS, IMPLIED, ARISING BY ESTOPPEL OR OTHERWISE, TO ANY INTELLECTUAL PROPERTY RIGHTS IS GRANTED BY THIS DOCUMENT.

TESTING AND OTHER QUALITY CONTROLS ARE USED TO THE EXTENT NATIONAL DEEMS NECESSARY TO SUPPORT NATIONAL'S PRODUCT WARRANTY. EXCEPT WHERE MANDATED BY GOVERNMENT REQUIREMENTS, TESTING OF ALL PARAMETERS OF EACH PRODUCT IS NOT NECESSARILY PERFORMED. NATIONAL ASSUMES NO LIABILITY FOR APPLICATIONS ASSISTANCE OR BUYER PRODUCT DESIGN. BUYERS ARE RESPONSIBLE FOR THEIR PRODUCTS AND APPLICATIONS USING NATIONAL COMPONENTS. PRIOR TO USING OR DISTRIBUTING ANY PRODUCTS THAT INCLUDE NATIONAL COMPONENTS, BUYERS SHOULD PROVIDE ADEQUATE DESIGN, TESTING AND OPERATING SAFEGUARDS.

EXCEPT AS PROVIDED IN NATIONAL'S TERMS AND CONDITIONS OF SALE FOR SUCH PRODUCTS, NATIONAL ASSUMES NO LIABILITY WHATSOEVER, AND NATIONAL DISCLAIMS ANY EXPRESS OR IMPLIED WARRANTY RELATING TO THE SALE AND/OR USE OF NATIONAL PRODUCTS INCLUDING LIABILITY OR WARRANTIES RELATING TO FITNESS FOR A PARTICULAR PURPOSE, MERCHANTABILITY, OR INFRINGEMENT OF ANY PATENT, COPYRIGHT OR OTHER INTELLECTUAL PROPERTY RIGHT.

LIFE SUPPORT POLICY

NATIONAL'S PRODUCTS ARE NOT AUTHORIZED FOR USE AS CRITICAL COMPONENTS IN LIFE SUPPORT DEVICES OR SYSTEMS WITHOUT THE EXPRESS PRIOR WRITTEN APPROVAL OF THE CHIEF EXECUTIVE OFFICER AND GENERAL COUNSEL OF NATIONAL SEMICONDUCTOR CORPORATION. As used herein:

Life support devices or systems are devices which (a) are intended for surgical implant into the body, or (b) support or sustain life and whose failure to perform when properly used in accordance with instructions for use provided in the labeling can be reasonably expected to result in a significant injury to the user. A critical component is any component in a life support device or system whose failure to perform can be reasonably expected to cause the failure of the life support device or system or to affect its safety or effectiveness.

National Semiconductor and the National Semiconductor logo are registered trademarks of National Semiconductor Corporation. All other brand or product names may be trademarks or registered trademarks of their respective holders.

Copyright© 2009 National Semiconductor Corporation

For the most current product information visit us at www.national.com



**National Semiconductor
Americas Technical
Support Center**
Email: support@nsc.com
Tel: 1-800-272-9959

**National Semiconductor Europe
Technical Support Center**
Email: europe.support@nsc.com
German Tel: +49 (0) 180 5010 771
English Tel: +44 (0) 870 850 4288

**National Semiconductor Asia
Pacific Technical Support Center**
Email: ap.support@nsc.com

**National Semiconductor Japan
Technical Support Center**
Email: jpn.feedback@nsc.com