

# LM25011

## 42V, 2A Constant On-Time Switching Regulator with Adjustable Current Limit

### General Description

The LM25011 Constant On-time Step-Down Switching Regulator features all the functions needed to implement a low cost, efficient, buck bias regulator capable of supplying up to 2A of load current. This high voltage regulator contains an N-Channel Buck switch, a startup regulator, current limit detection, and internal ripple control. The constant on-time regulation principle requires no loop compensation, results in fast load transient response, and simplifies circuit implementation. The operating frequency remains constant with line and load. The adjustable valley current limit detection results in a smooth transition from constant voltage to constant current mode when current limit is reached, without the use of current limit foldback. The PGD output indicates the output voltage has increased to within 5% of the expected regulation value. Additional features include: Low output ripple, VIN under-voltage lock-out, adjustable soft-start timing, thermal shutdown, gate drive pre-charge, gate drive under-voltage lock-out, and maximum duty cycle limit.

### Features

- Input operating voltage range: 6V to 42V
- Absolute maximum input rating: 45V
- Integrated 2A N-Channel Buck Switch
- Adjustable current limit
- Adjustable output voltage from 2.51V
- Minimum ripple voltage at  $V_{OUT}$
- Power Good output
- Switching frequency adjustable to 2 MHz
- Switching frequency remains nearly constant with load current and input voltage variations
- Ultra-fast transient response
- No loop compensation required
- Stable operation with ceramic output capacitors
- Adjustable Soft-Start timing
- Thermal shutdown
- Precision 2% feedback reference

### Package

- MSOP-10EP

### Typical Application, Basic Step-Down Regulator

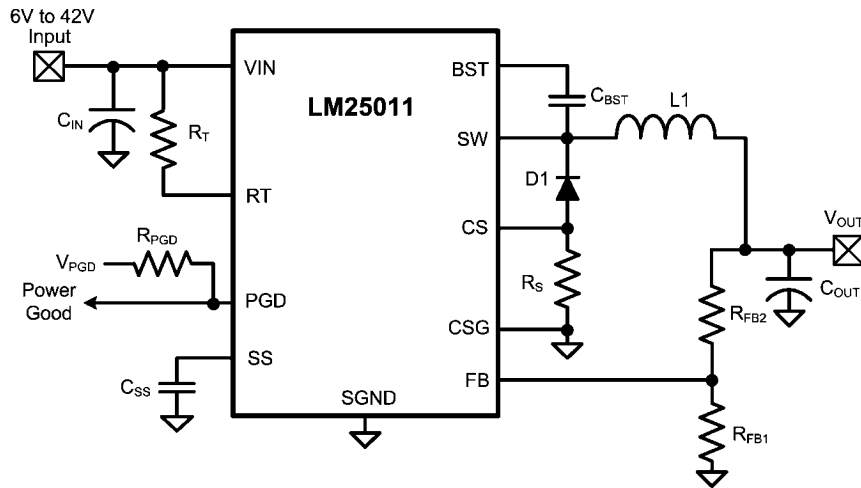

30094601

## Connection Diagram

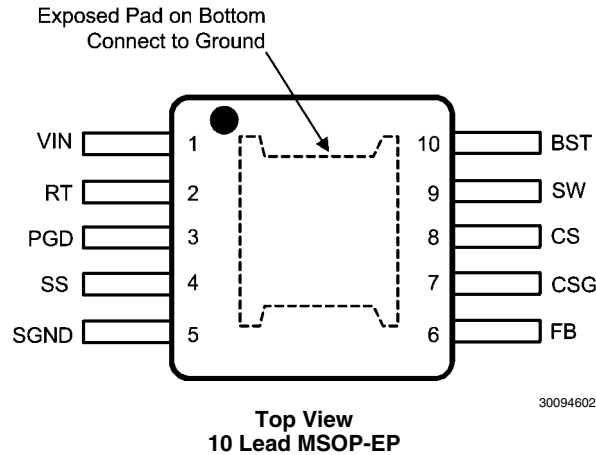

## Ordering Information

Order Number	Package Type	NSC Package Drawing	Supplied As
LM25011MY	MSOP-10EP	MUC10A	1000 Units on Tape and Reel
LM25011MYX	MSOP-10EP	MUC10A	3500 Units on Tape and Reel

## Pin Descriptions

Pin No.	Name	Description	Application Information
1	VIN	Input supply voltage	Operating input range is 6V to 42V. Transient capability is 45V. A low ESR capacitor must be placed as close as possible to the VIN and SGND pins.
2	RT	On-time Control	An external resistor from VIN to this pin sets the buck switch on-time, and the switching frequency.
3	PGD	Power Good	Logic output indicates when the voltage at the FB pin has increased to above 95% of the internal reference voltage. Hysteresis is provided. An external pull-up resistor to a voltage less than 7V is required.
4	SS	Soft-Start	An internal current source charges an external capacitor to provide the soft-start function.
5	SGND	Signal Ground	Ground for all internal circuitry other than the current limit sense circuit.
6	FB	Feedback	Internally connected to the regulation comparator. The regulation level is 2.51V.
7	CSG	Current Sense Ground	Ground connection for the current limit sensing circuit. Connect to ground and to the current sense resistor.
8	CS	Current sense	Connect to the current sense resistor and the anode of the free-wheeling diode.
9	SW	Switching Node	Internally connected to the buck switch source. Connect to the external inductor, cathode of the free-wheeling diode, and bootstrap capacitor.
10	BST	Bootstrap capacitor connection of the buck switch gate driver.	Connect a 0.1 $\mu$ F capacitor from SW to this pin. The capacitor is charged during the buck switch off-time via an internal diode.

## Absolute Maximum Ratings *(Note 1)*

If Military/Aerospace specified devices are required, please contact the National Semiconductor Sales Office/Distributors for availability and specifications.

VIN to SGND ( $T_J = 25^\circ\text{C}$ )	45V
BST to SGND	52V
SW to SGND (Steady State)	-1.5V to 45V
BST to SW	-0.3V to 7V
CS to CSG	-0.3V to 0.3V
CSG to SGND	-0.3V to 0.3V
PGD to SGND	-0.3V to 7V
SS to SGND	-0.3V to 3V

RT to SGND	-0.3V to 1V
FB to SGND	-0.3V to 7V
ESD Rating <i>(Note 2)</i>	
Human Body Model	2kV
Lead Temperature (soldering 4 sec)	260°C
Storage Temperature Range	-65°C to +150°C
Junction Temperature	150°C

## Operating Ratings *(Note 1)*

VIN Voltage	6.0V to 42V
Junction Temperature	-40°C to +125°C

**Electrical Characteristics** Specifications with standard type are for  $T_J = 25^\circ\text{C}$  only; limits in **boldface type** apply over the full Operating Junction Temperature ( $T_J$ ) range. Minimum and Maximum limits are guaranteed through test, design, or statistical correlation. Typical values represent the most likely parametric norm at  $T_J = 25^\circ\text{C}$ , and are provided for reference purposes only. Unless otherwise stated the following conditions apply:  $V_{IN} = 12\text{V}$ ,  $R_T = 50\text{ k}\Omega$ .

Symbol	Parameter	Conditions	Min	Typ	Max	Units
<b>Input (VIN Pin)</b>						
$I_{IN}$	Input operating current	Non-switching, FB = 3V		1200	<b>1600</b>	$\mu\text{A}$
$UVLO_{VIN}$	VIN under-voltage lock-out threshold	VIN Increasing	<b>4.6</b>	5.3	<b>5.9</b>	V
	VIN under-voltage lock-out threshold hysteresis			200		mV
<b>Switch Characteristics</b>						
$R_{DS(ON)}$	Buck Switch $R_{DS(ON)}$	$I_{TEST} = 200\text{ mA}$		0.3	<b>0.6</b>	$\Omega$
$UVLO_{GD}$	Gate Drive UVLO	BST-SW	<b>2.4</b>	3.4	<b>4.4</b>	V
	$UVLO_{GD}$ Hysteresis			350		mV
	Pre-charge switch voltage	$I_{TEST} = 10\text{ mA}$ into SW pin		1.4		V
	Pre-charge switch on-time			120		ns
<b>Soft-Start Pin</b>						
$V_{SS}$	Pull-up voltage			2.51		V
$I_{SS}$	Internal current source			10		$\mu\text{A}$
$V_{SS-SH}$	Shutdown Threshold		<b>70</b>	140		mV
<b>Current Limit</b>						
$V_{ILIM}$	Threshold voltage at CS		<b>-146</b>	-130	<b>-115</b>	mV
	CS bias current	FB = 3V		-120		$\mu\text{A}$
	CSG bias current	FB = 3V		-35		$\mu\text{A}$
<b>On Timer, RT Pin</b>						
$t_{ON-1}$	On-time	$V_{IN} = 12\text{V}$ , $R_T = 50\text{ k}\Omega$	<b>150</b>	200	<b>250</b>	ns
$t_{ON-2}$	On-time	$V_{IN} = 32\text{V}$ , $R_T = 50\text{ k}\Omega$		75		ns
$t_{ON-3}$	On-time (current limit)	$V_{IN} = 12\text{V}$ , $R_T = 50\text{ k}\Omega$		100		ns
$t_{ON-4}$	On-time	$V_{IN} = 12\text{V}$ , $R_T = 301\text{ k}\Omega$		1020		ns
<b>Off Timer</b>						
$t_{OFF}$	Minimum Off-time		<b>90</b>	150	<b>208</b>	ns
<b>Regulation Comparator (FB Pin)</b>						
$V_{REF}$	FB regulation threshold	SS pin = steady state	<b>2.46</b>	2.51	<b>2.56</b>	V
	FB bias current	FB = 3V		100		nA

Symbol	Parameter	Conditions	Min	Typ	Max	Units
<b>Power Good (PGD pin)</b>						
	Threshold at FB, with respect to $V_{REF}$	FB increasing	<b>91</b>	95		%
	Threshold hysteresis			3.3		%
$PGD_{VOL}$	Low state voltage	$I_{PGD} = 1\text{mA}$ , $FB = 0V$		125	<b>180</b>	mV
$PGD_{LKG}$	Off state leakage	$V_{PGD} = 7V$ , $FB = 3V$		0.1		$\mu A$
<b>Thermal Shutdown</b>						
$T_{SD}$	Thermal shutdown	Junction temperature increasing		155		$^{\circ}C$
	Thermal shutdown hysteresis			20		$^{\circ}C$
<b>Thermal Resistance</b>						
$\theta_{JA}$	Junction to Ambient, 0 LFPM Air Flow (note 3)			48		$^{\circ}C/W$
$\theta_{JC}$	Junction to Case, (note 3)			10		$^{\circ}C/W$

**Note 1:** Absolute Maximum Ratings are limits beyond which damage to the device may occur. Operating Ratings are conditions under which operation of the device is intended to be functional. For guaranteed specifications and test conditions, see the Electrical Characteristics.

**Note 2:** The human body model is a 100 pF capacitor discharged through a 1.5k $\Omega$  resistor into each pin.

**Note 3:** JEDEC test board description can be found in JESD 51-5 and JESD 51-7.

**Note 4:** Current flow out of a pin is indicated as a negative number.

# Typical Performance Characteristics

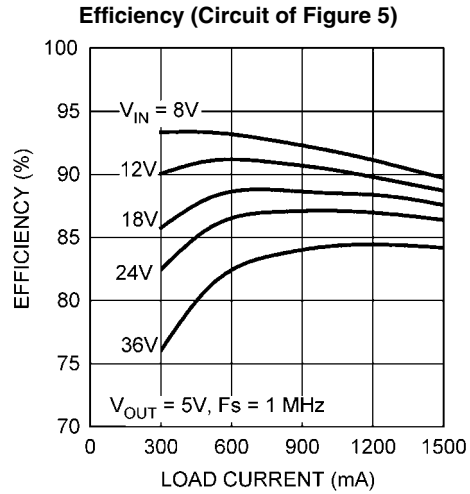

30094603

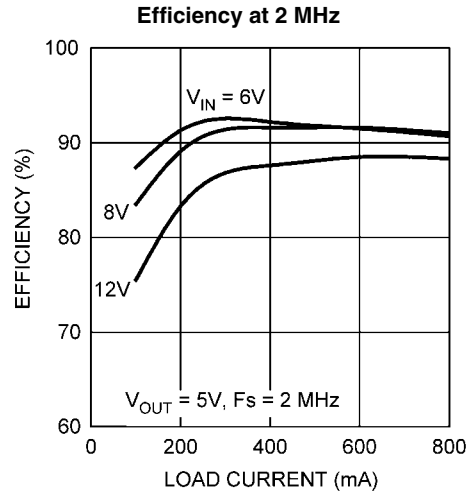

30094604

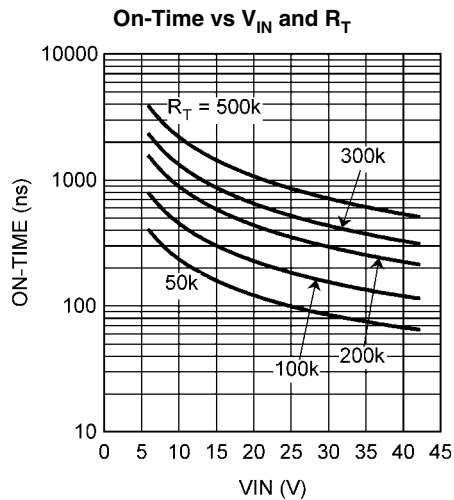

30094605

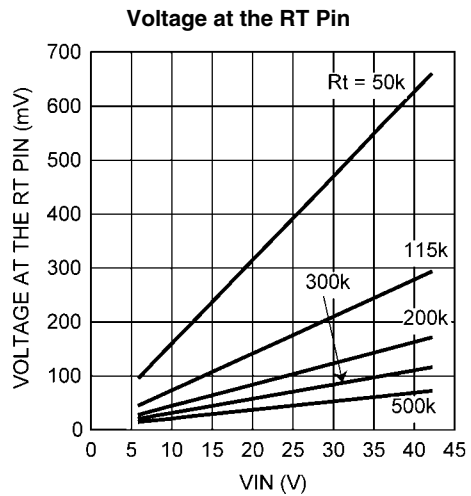

30094606

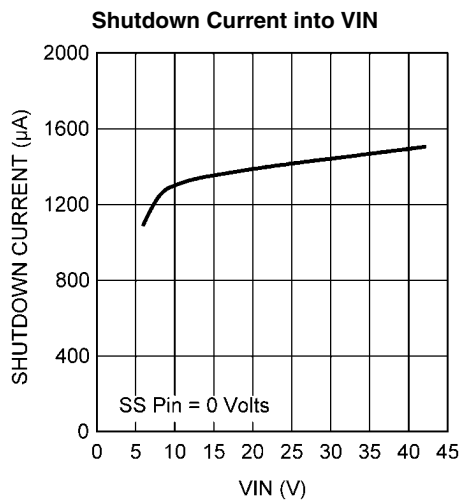

30094607

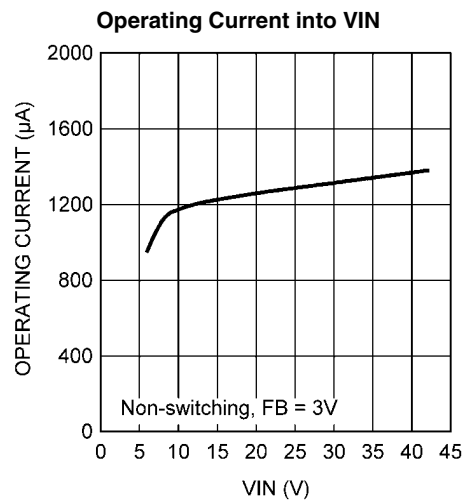

30094608

**PGD Low Voltage vs. Sink Current**

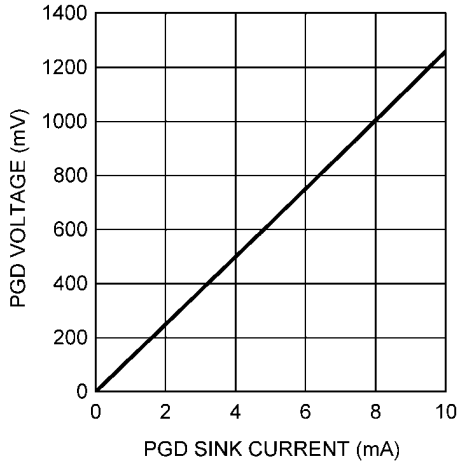

30094609

**Reference Voltage vs. Temperature**

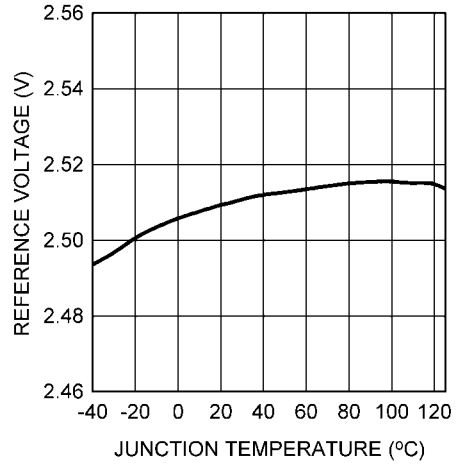

30094610

**Current Limit Threshold vs. Temperature**

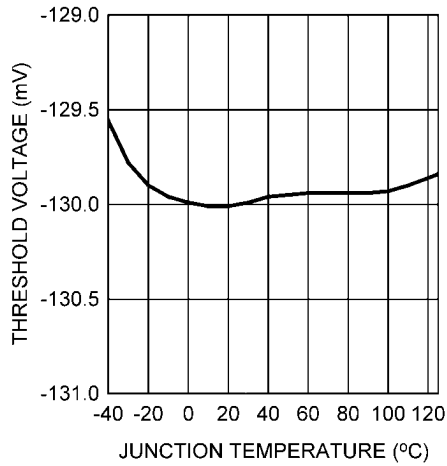

30094611

**Operating Current vs. Temperature**

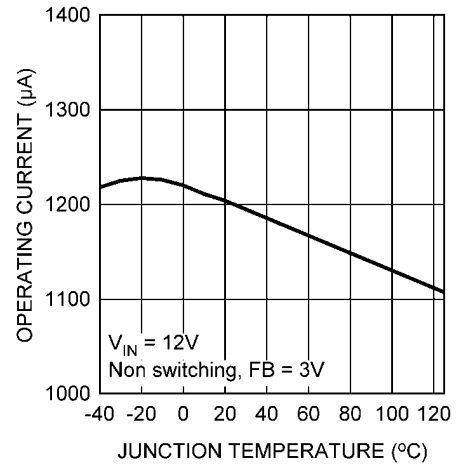

30094612

**VIN UVLO vs. Temperature**

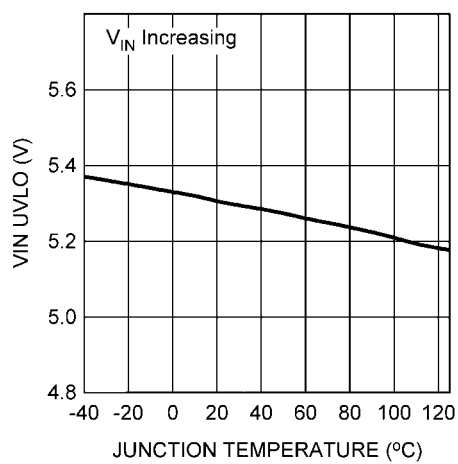

30094613

**SS Pin Shutdown Threshold vs. Temperature**

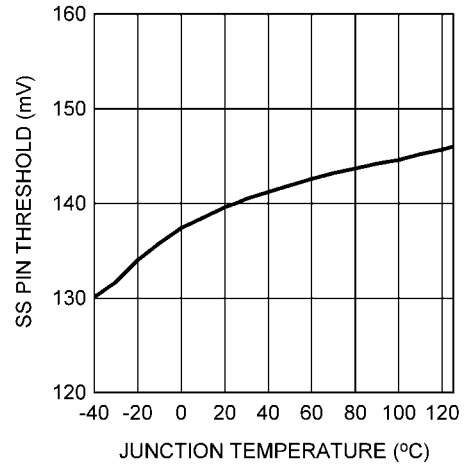

30094614

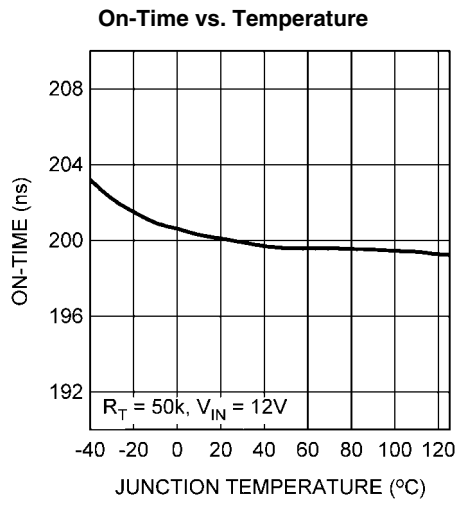

30094615

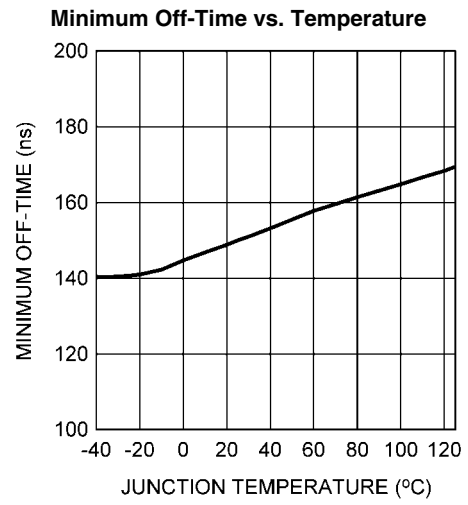

30094616

# Block Diagram

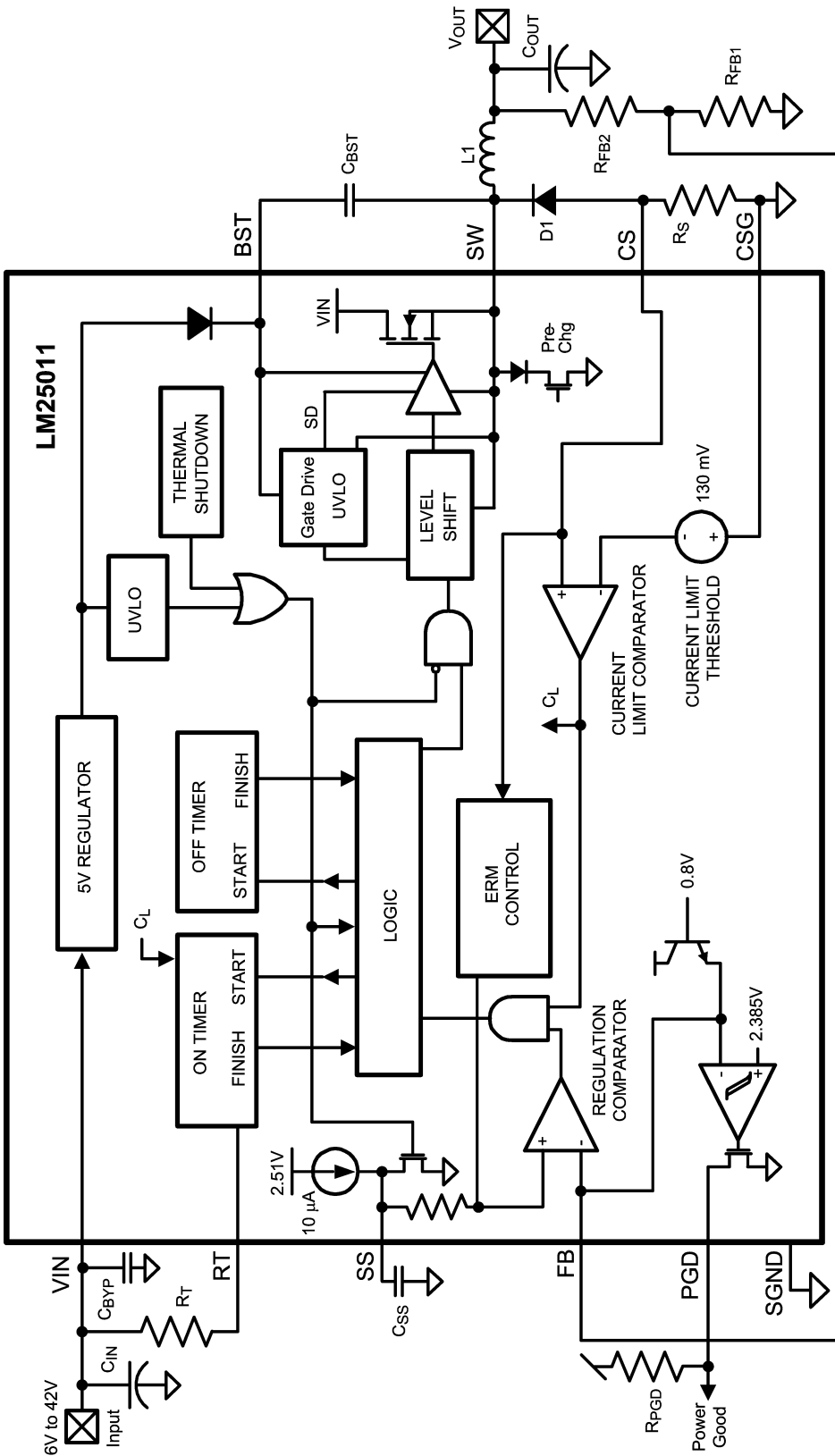

30094617

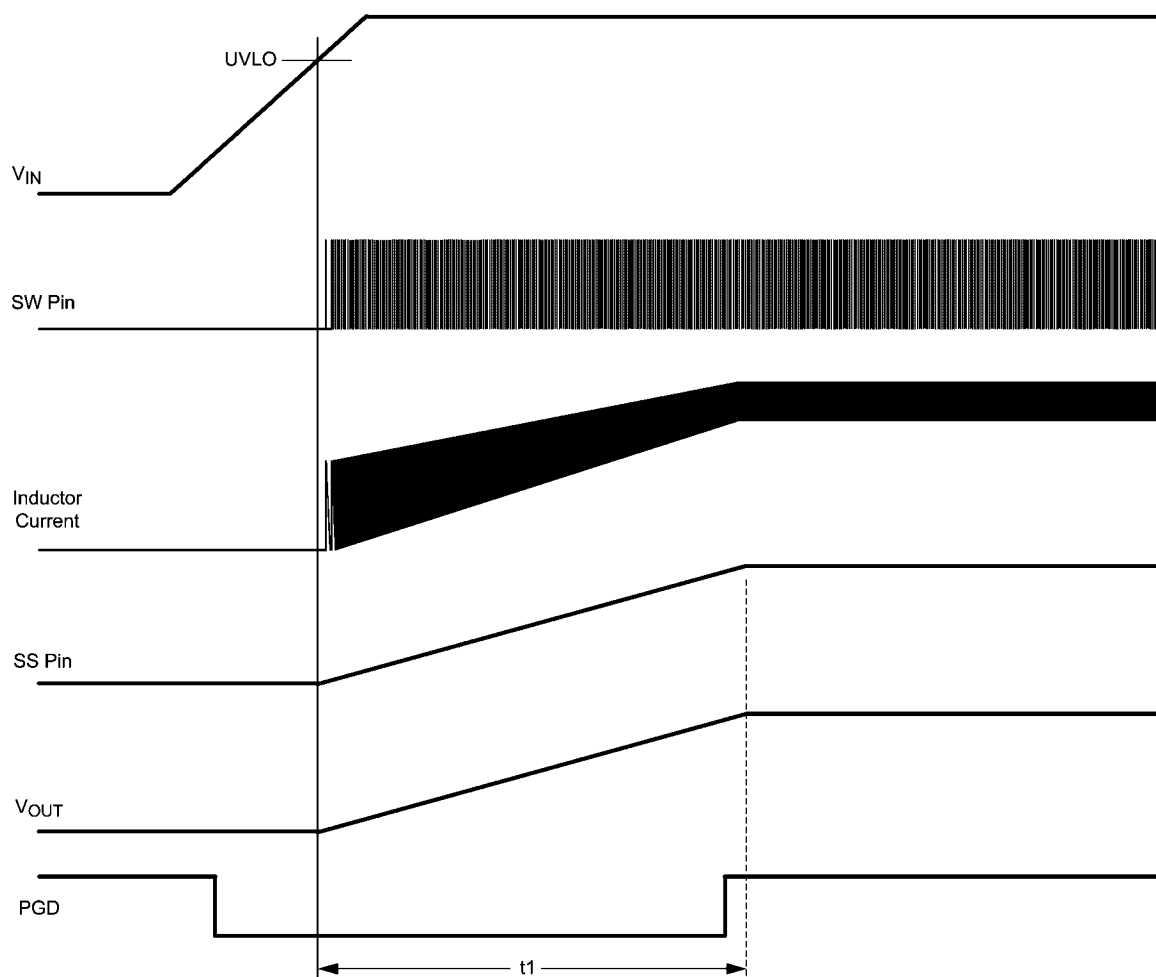

30094618

FIGURE 1. Startup Sequence

## Functional Description

The LM25011 Constant On-time Step-down Switching Regulator features all the functions needed to implement a low cost, efficient buck bias power converter capable of supplying up to 2.0A to the load. This high voltage regulator contains an N-Channel buck switch, is easy to implement, and is available in a 10-pin MSOP power enhanced package. The regulator's operation is based on a constant on-time control principle with the on-time inversely proportional to the input voltage. This feature results in the operating frequency remaining relatively constant with load and input voltage variations. The constant on-time feedback control principle requires no loop compensation resulting in very fast load transient response. The adjustable valley current limit detection results in a smooth transition from constant voltage to constant current when current limit is reached. To aid in controlling excessive switch current due to a possible saturating inductor the on-time is reduced by  $\approx 40\%$  when current limit is detected. The Power Good output (PGD pin) indicates when the output voltage is within 5% of the expected regulation voltage.

The LM25011 can be implemented to efficiently step-down higher voltages in non-isolated applications. Additional features include: Low output ripple,  $V_{IN}$  under-voltage lock-out, adjustable soft-start timing, thermal shutdown, gate drive pre-

charge, gate drive under-voltage lock-out, and maximum duty cycle limit.

## Control Circuit Overview

The LM25011 buck regulator employs a control principle based on a comparator and a one-shot on-timer, with the output voltage feedback (FB) compared to an internal reference (2.51V). If the FB voltage is below the reference the internal buck switch is switched on for the one-shot timer period, which is a function of the input voltage and the programming resistor ( $R_T$ ). Following the on-time the switch remains off until the FB voltage falls below the reference, but never less than the minimum off-time forced by the off-time one-shot timer. When the FB pin voltage falls below the reference and the off-time one-shot period expires, the buck switch is then turned on for another on-time one-shot period.

When in regulation, the LM25011 operates in continuous conduction mode at heavy load currents and discontinuous conduction mode at light load currents. In continuous conduction mode the inductor's current is always greater than zero, and the operating frequency remains relatively constant with load and line variations. The minimum load current for continuous conduction mode is one-half the inductor's ripple current am-

plitude. The approximate operating frequency is calculated as follows:

$$F_S = \frac{V_{OUT}}{(4.1 \times 10^{-11} \times (R_T + 0.5k)) + (V_{IN} \times 15 \text{ ns})} \quad (1)$$

The buck switch duty cycle is approximately equal to:

$$DC = \frac{t_{ON}}{t_{ON} + t_{OFF}} = t_{ON} \times F_S = \frac{V_{OUT}}{V_{IN}} \quad (2)$$

When the load current is less than one half the inductor's ripple current amplitude the circuit operates in discontinuous conduction mode. The off-time is longer than in continuous conduction mode while the inductor current is zero, causing the switching frequency to reduce as the load current is reduced. Conversion efficiency is maintained at light loads since the switching losses are reduced with the reduction in load and frequency. The approximate discontinuous operating frequency can be calculated as follows:

$$F_S = \frac{V_{OUT}^2 \times L_1 \times 1.19 \times 10^{21}}{R_L \times R_T^2} \quad (3)$$

where  $R_L$  = the load resistance, and  $L_1$  is the circuit's inductor. The output voltage is set by the two feedback resistors ( $R_{FB1}$ ,  $R_{FB2}$  in the Block Diagram). The regulated output voltage is calculated as follows:

$$V_{OUT} = 2.51V \times (R_{FB1} + R_{FB2}) / R_{FB1} \quad (4)$$

Ripple voltage, which is required at the input of the regulation comparator for proper output regulation, is generated internally by the LM25011's ERM (Emulated Ripple Mode) control block. The ERM circuit generates the required internal ripple voltage from the ripple waveform at the CS pin during each off-time. This feature eliminates the need for ripple at  $V_{OUT}$ , allowing output ripple to be kept to a minimum. Output ripple is therefore a function of the inductor's ripple current and the characteristics of the output capacitor.

## On-Time Timer

The on-time for the LM25011 is determined by the  $R_T$  resistor and the input voltage ( $V_{IN}$ ), calculated from:

$$t_{ON} = \frac{4.1 \times 10^{-11} \times (R_T + 500\Omega)}{(V_{IN})} + 15 \text{ ns} \quad (5)$$

The inverse relationship with  $V_{IN}$  results in a nearly constant frequency as  $V_{IN}$  is varied. To set a specific continuous conduction mode switching frequency ( $F_S$ ), the  $R_T$  resistor is determined from the following:

$$R_T = \frac{V_{OUT} - (V_{IN} \times F_S \times 15 \text{ ns})}{F_S \times 4.1 \times 10^{-11}} - 500\Omega \quad (6)$$

The on-time must be chosen greater than 90 ns for proper operation. Equations 1, 5 and 6 are valid only during normal operation - i.e., the circuit is not in current limit. When the LM25011 operates in current limit, the on-time is reduced by  $\approx 40\%$ . This feature reduces the peak inductor current which may be excessively high if the load current and the input voltage are simultaneously high. This feature operates on a cycle-by-cycle basis until the load current is reduced and the output voltage resumes its normal regulated value. The maximum continuous current into the RT pin must be less than 2 mA. For high frequency applications, the maximum switching frequency is limited at the maximum input voltage by the minimum on-time one-shot period (90 ns). At minimum input voltage the maximum switching frequency is limited by the minimum off-time one-shot period, which, if reached, prevents achievement of the proper duty cycle.

## Current Limit

Current limit detection occurs during the off-time by monitoring the voltage across the external current sense resistor  $R_S$ . Referring to the Block Diagram, during the off-time the recirculating current flows through the inductor, through the load, through the sense resistor, and through D1 to the inductor. If the voltage across the sense resistor exceeds the threshold ( $V_{ILIM}$ ) the current limit comparator output switches to delay the start of the next on-time period. The next on-time starts when the recirculating current decreases such that the voltage across  $R_S$  reduces to the threshold and the voltage at FB is below 2.51V. The operating frequency is typically lower due to longer-than-normal off-times. When current limit is detected, the on-time is reduced by  $\approx 40\%$  if the voltage at the FB pin is below its threshold when the voltage across  $R_S$  reduces to its threshold ( $V_{OUT}$  is low due to current limiting).

Figure 2 illustrates the inductor current waveform during normal operation and in current limit. During the first "Normal Operation" the load current is  $I_{O1}$ , the average of the inductor current waveform. As the load resistance is reduced, the inductor current increases until the lower peak of the inductor ripple current exceeds the threshold. During the "Current Limited" portion of Figure 2, each on-time is reduced by  $\approx 40\%$ , resulting in lower ripple amplitude for the inductor's current. During this time the LM25011 is in a constant current mode with an average load current equal to the current limit threshold plus half the ripple amplitude ( $I_{OCL}$ ), and the output voltage is below the normal regulated value. Normal operation resumes when the load current is reduced (to  $I_{O2}$ ), allowing  $V_{OUT}$  and the on-time to return to their normal values. Note that in the second period of "Normal Operation", even though the inductor's peak current exceeds the current limit threshold during part of each cycle, the circuit is not in current limit since the inductor current falls below the current limit threshold during each off time. The peak current allowed through the buck switch is 3.5A, and the maximum allowed average current is 2.0A.

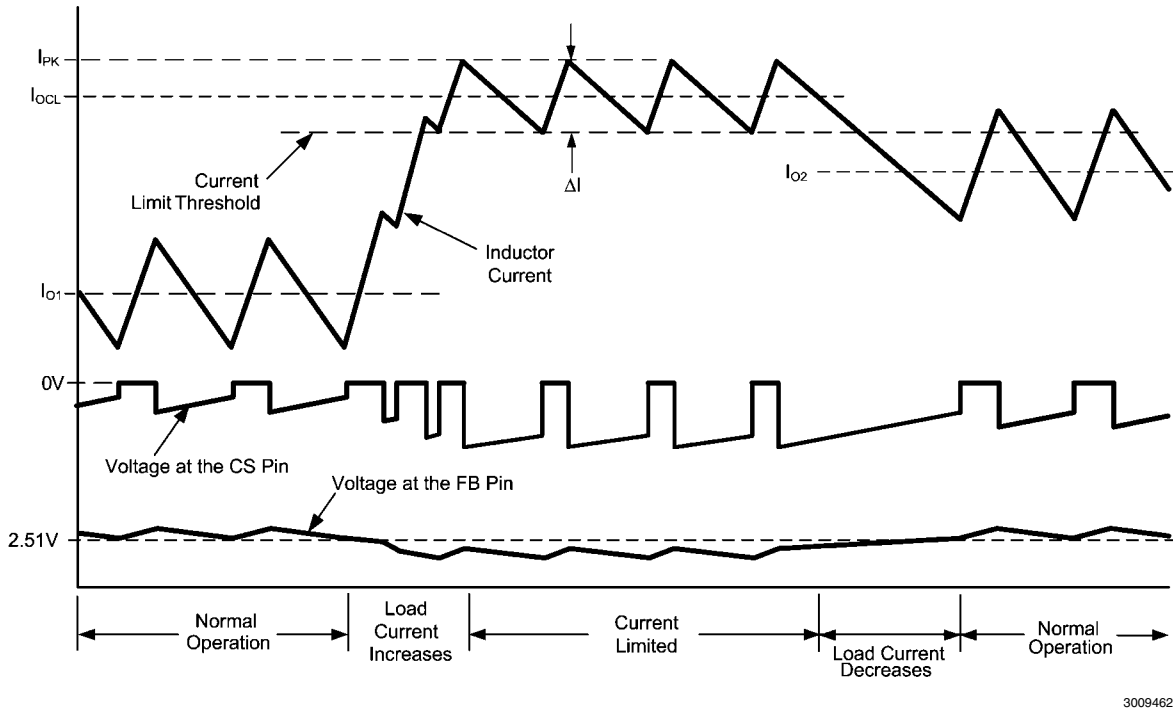

FIGURE 2. Normal and Current Limit Operation

## Ripple Requirements

The LM25011 requires a minimum of 10 mVp-p ripple voltage at the CS pin. That ripple voltage is generated by the decreasing recirculating current (the inductor's ripple current) through  $R_S$  during the off-time. See Figure 3.

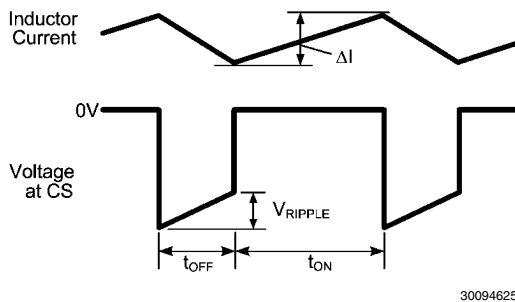

FIGURE 3. CS Pin Waveform

The ripple voltage is equal to:

$$V_{\text{RIPPLE}} = \Delta I \times R_S$$

where  $\Delta I$  is the inductor current ripple amplitude, and  $R_S$  is the current sense resistor at the CS pin.

## N-Channel Buck Switch and Driver

The LM25011 integrates an N-Channel buck switch and associated floating high voltage gate driver. The gate driver circuit works in conjunction with an external bootstrap capacitor ( $C_{\text{BST}}$ ) and an internal high voltage diode. A 0.1  $\mu\text{F}$  capacitor connected between BST and SW provides the supply voltage for the driver during the on-time. During each off-time, the SW pin is at approximately -1V, and  $C_{\text{BST}}$  is recharged

from the internal 5V regulator for the next on-time. The minimum off-time ensures a sufficient time each cycle to recharge the bootstrap capacitor.

## Soft-Start

The soft-start feature allows the converter to gradually reach a steady state operating point, thereby reducing startup stresses and current surges. Upon turn-on, when  $V_{\text{IN}}$  reaches its under-voltage lock-out threshold an internal 10  $\mu\text{A}$  current source charges the external capacitor at the SS pin to 2.51V ( $t_1$  in Figure 1). The ramping voltage at SS ramps the non-inverting input of the regulation comparator, and the output voltage, in a controlled manner. For proper operation, the soft-start capacitor should be no smaller than 1000 pF.

The LM25011 can be employed as a tracking regulator by applying the controlling voltage to the SS pin. The regulator's output voltage tracks the applied voltage, gained up by the ratio of the feedback resistors. The applied voltage at the SS pin must be within the range of 0.5V to 2.6V. The absolute maximum rating for the SS pin is 3.0V. If the tracking function causes the voltage at the FB pin to go below the thresholds for the PGD pin, the PGD pin will switch low (see the Power Good Output section). An internal switch grounds the SS pin if the input voltage at  $V_{\text{IN}}$  is below its under-voltage lock-out threshold or if the Thermal Shutdown activates. If the tracking function (described above) is used, the tracking voltage applied to the SS pin must be current limited to a maximum of 1 mA.

## Shutdown Function

The SS pin can be used to shutdown the LM25011 by grounding the SS pin as shown in Figure 4. Releasing the pin allows normal operation to resume.

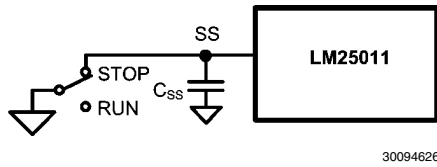

FIGURE 4. Shutdown Implementation

## Power Good Output (PGD)

The Power Good output (PGD) indicates when the voltage at the FB pin is close to the internal 2.51V reference voltage. The rising threshold at the FB pin for the PGD output to switch high is 95% of the internal reference. The falling threshold for the PGD output to switch low is approximately 3.3% below the rising threshold.

The PGD pin is internally connected to the drain of an N-channel MOSFET switch. An external pull-up resistor ( $R_{PGD}$ ), connected to an appropriate voltage not exceeding 7V, is required at PGD to indicate the LM25011's status to other circuitry. When PGD is low, the pin's voltage is determined by the current into the pin. See the graph "PGD Low Voltage vs. Sink Current".

Upon powering up the LM25011, the PGD pin is high until the voltage at  $V_{IN}$  reaches 2V, at which time PGD switches low. As  $V_{IN}$  is increased PGD stays low until the output voltage takes the voltage at the FB pin above 95% of the internal reference voltage, at which time PGD switches high. As  $V_{IN}$  is decreased (during shutdown) PGD remains high until either the voltage at the FB pin falls below  $\approx 92\%$  of the internal reference, or when  $V_{IN}$  falls below its lower UVLO threshold, whichever occurs first. PGD then switches low, and remains low until  $V_{IN}$  falls below 2V, at which time PGD switches high. If the LM25011 is used as a tracking regulator (see the Soft-start section), the PGD output is high as long as the voltage at the FB pin is above the thresholds mentioned above.

## Thermal Shutdown

The LM25011 should be operated so the junction temperature does not exceed 125°C. If the junction temperature increases above that, an internal Thermal Shutdown circuit activates (typically) at 155°C, taking the controller to a low power reset state by disabling the buck switch and taking the SS pin to ground. This feature helps prevent catastrophic failures from accidental device overheating. When the junction temperature reduces below 135°C (typical hysteresis = 20°C) normal operation resumes.

## Applications Information

### EXTERNAL COMPONENTS

The procedure for calculating the external components is illustrated with a design example. Referring to the Block Diagram, the circuit is to be configured for the following specifications:

- $V_{OUT} = 5V$
- $V_{IN} = 8V$  to 36V
- Minimum load current for continuous conduction mode ( $I_{OUT(min)}$ ) = 300 mA
- Maximum load current ( $I_{OUT(max)}$ ) = 1.5 A
- Switching frequency ( $F_S$ ) = 1.0 MHz
- Soft-start time = 5 ms

**$R_{FB2}$  and  $R_{FB1}$ :** These resistors set the output voltage, and their ratio is calculated from:

$$R_{FB2}/R_{FB1} = (V_{OUT}/2.51V) - 1 \quad (7)$$

For this example,  $R_{FB2}/R_{FB1} = 0.992$ .  $R_{FB1}$  and  $R_{FB2}$  should be chosen from standard value resistors in the range of 1.0 k $\Omega$  – 10 k $\Omega$  which satisfy the above ratio. For this example, 4.99 k $\Omega$  is chosen for both resistors, providing a 5.02V output.

**$R_T$ :** This resistor sets the on-time, and (by default) the switching frequency. First check that the desired frequency does not require an on-time or off-time shorter than the minimum allowed values (90 ns and 150, respectively). The minimum on-time occurs at the maximum input voltage. For this example:

$$t_{ON(min)} = \frac{V_{OUT}}{V_{IN(max)} \times F_S} = \frac{5V}{36V \times 1 \text{ MHz}} = 139 \text{ ns}$$

The minimum off-time occurs at the minimum input voltage. For this example:

$$t_{OFF(min)} = \frac{V_{IN(min)} - V_{OUT}}{V_{IN(min)} \times F_S} = \frac{8V - 5V}{8V \times 1 \text{ MHz}} = 375 \text{ ns}$$

Both the on-time and off-time are acceptable since they are significantly greater than the minimum value for each. The  $R_T$  resistor is calculated from equation 6 using the minimum input voltage:

$$R_T = \frac{5 - (8V \times 1\text{MHz} \times 15 \text{ ns})}{1\text{MHz} \times 4.1 \times 10^{-11}} - 500\Omega = 118.5 \text{ k}\Omega$$

A standard value 118 k $\Omega$  resistor is selected. The minimum on-time calculates to 152 ns at  $V_{in} = 36V$ , and the maximum on-time calculates to 672 ns at  $V_{in} = 8V$

**L1:** The parameters controlled by the inductor are the inductor current ripple amplitude ( $I_{OR}$ ), and the ripple voltage amplitude across the current sense resistor  $R_S$ . The minimum load current is used to determine the maximum allowable ripple in order to maintain continuous conduction mode (the lower peak does not reach 0 mA). This is not a requirement of the LM25011, but serves as a guideline for selecting L1. For this example, the maximum ripple current should be less than:

$$I_{OR(max)} = 2 \times I_{OUT(min)} = 600 \text{ mA p-p} \quad (8)$$

For applications where the minimum load current is zero, a good starting point for allowable ripple is 20% of the maximum load current. In this case substitute 20% of  $I_{OUT(max)}$  for  $I_{OUT(min)}$  in equation 8. The ripple amplitude calculated in Equation 8 is then used in the following equation:

$$L1_{(min)} = \frac{t_{ON(min)} \times (V_{IN(max)} - V_{OUT})}{I_{OR(max)}} = 7.85 \mu\text{H}$$

A standard value 10  $\mu\text{H}$  inductor is chosen. Using this inductor value, the maximum ripple current amplitude, which occurs at maximum  $V_{IN}$ , calculates to 472 mA p-p, and the peak current is 1736 mA at maximum load current. Ensure the selected inductor is rated for this peak current. The minimum ripple current, which occurs at minimum  $V_{IN}$ , calculates to 200 mA p-p.

**$R_S$ :** The minimum current limit threshold is calculated at maximum load current, using the minimum ripple current calculated above. The current limit threshold is the lower peak of the inductor current waveform when in current limit (see Figure 2).

$$I_{LIM} = 1.5A - (0.2 \text{ A}/2) = 1.4A$$

Current limit detection occurs when the voltage across the sense resistor ( $R_S$ ) reaches the current limit threshold. To allow for tolerances, the sense resistor value is calculated using the minimum threshold specification:

$$R_S = 115 \text{ mV}/1.4\text{A} = 82 \text{ m}\Omega$$

The next smaller standard value, 80 m $\Omega$ , is selected. The next step is to ensure that sufficient ripple voltage occurs across  $R_S$  with this value sense resistor. As mentioned in the Ripple Requirements section, a minimum of 10mVp-p voltage ripple is required across the  $R_S$  sense resistor during the off-time to ensure the regulation circuit operates properly. The ripple voltage is the product of the inductor ripple current amplitude and the sense resistor value. In this case, the minimum ripple voltage calculates to:

$$V_{\text{RIPPLE}} = \Delta I \times R_S = 200 \text{ mA} \times 0.080\Omega = 16 \text{ mV}$$

If the ripple voltage had calculated to less than 10 mVp-p the inductor value would have to be reduced to increase the ripple current amplitude. This would have required a recalculation of  $I_{\text{LIM}}$  and  $R_S$  in the above equations. Since the minimum requirement is satisfied in this case no change is necessary.

The nominal current limit threshold calculates to 1.63A. The minimum and maximum thresholds calculate to 1.44A and 1.83A respectively, using the minimum and maximum limits for the current limit threshold specification. The load current is equal to the threshold current plus one half the ripple current. Under normal load conditions, the maximum power dissipation in  $R_S$  occurs at maximum load current, and at maximum input voltage where the on-time duty cycle is minimum. In this design example, the minimum on-time duty cycle is:

$$\text{Duty Cycle} = D = \frac{V_{\text{OUT}}}{V_{\text{IN}}} = \frac{5\text{V}}{36\text{V}} = 13.9\%$$

At maximum load current, the power dissipation in  $R_S$  is equal to:

$$P_{(\text{RS})} = (1.5\text{A})^2 \times 0.080\Omega \times (1 - 0.139) = 155 \text{ mW}$$

When in current limit the maximum power dissipation in  $R_S$  calculates to

$$P_{(\text{RS})} = (1.83\text{A} + 0.472\text{A}/4)^2 \times 0.080\Omega = 304 \text{ mW}$$

Duty cycle is not included in this power calculation since the on-time duty cycle is typically <5% when in current limit.

**$C_{\text{OUT}}$ :** The output capacitor should typically be no smaller than 3.3  $\mu\text{F}$ , although that is dependent on the frequency and the desired output characteristics.  $C_{\text{OUT}}$  should be a low ESR good quality ceramic capacitor. Experimentation is usually necessary to determine the minimum value for  $C_{\text{OUT}}$ , as the nature of the load may require a larger value. A load which creates significant transients requires a larger value for  $C_{\text{OUT}}$  than a non-varying load.

**$C_{\text{IN}}$  and  $C_{\text{BYP}}$ :** The purpose of  $C_{\text{IN}}$  is to supply most of the switch current during the on-time, and limit the voltage ripple

at  $V_{\text{IN}}$ , since it is assumed the voltage source feeding  $V_{\text{IN}}$  has some amount of source impedance. When the buck switch turns on, the current into  $V_{\text{IN}}$  suddenly increases to the lower peak of the inductor's ripple current, then ramps up to the upper peak, then drops to zero at turn-off. The average current during the on-time is the average load current. For a worst case calculation,  $C_{\text{IN}}$  must supply this average load current during the maximum on-time, without letting the voltage at the VIN pin drop below a minimum operating level of 5.5V. For this exercise 0.5V is chosen as the maximum allowed input ripple voltage. Using the maximum load current, the minimum value for  $C_{\text{IN}}$  is calculated from:

$$C_{\text{IN}} = \frac{I_{\text{OUT(max)}} \times t_{\text{ON(max)}}}{\Delta V} = \frac{1.5\text{A} \times 672 \text{ ns}}{0.5\text{V}} = 2.02 \mu\text{F} \quad (9)$$

where  $t_{\text{ON}}$  is the maximum on-time, and  $\Delta V$  is the allowable ripple voltage at  $V_{\text{IN}}$ . The purpose of  $C_{\text{BYP}}$  is to minimize transients and ringing due to long lead inductance leading to the VIN pin. A low ESR 0.1  $\mu\text{F}$  ceramic chip capacitor is recommended, and  $C_{\text{BYP}}$  must be located close to the VIN and SGND pins.

**$C_{\text{BST}}$ :** The recommended value for  $C_{\text{BST}}$  is 0.1  $\mu\text{F}$ . A high quality ceramic capacitor with low ESR is recommended as  $C_{\text{BST}}$  supplies a surge current to charge the buck switch gate at each turn-on. A low ESR also helps ensure a complete recharge during each off-time.

**$C_{\text{SS}}$ :** The capacitor at the SS pin determines the soft-start time, i.e. the time for the output voltage to reach its final value ( $t_1$  in Figure 1). For a soft-start time of 5 ms, the capacitor value is determined from the following:

$$C_{\text{SS}} = \frac{5 \text{ ms} \times 10 \mu\text{A}}{2.51\text{V}} = 0.02 \mu\text{F}$$

**D1:** A Schottky diode is recommended. Ultra-fast recovery diodes are not recommended as the high speed transitions at the SW pin may affect the regulator's operation due to the diode's reverse recovery transients. The diode must be rated for the maximum input voltage, the maximum load current, and the peak current which occurs when the current limit and maximum ripple current are reached simultaneously. The diode's average power dissipation is calculated from:

$$P_{\text{D1}} = V_F \times I_{\text{OUT}} \times (1 - D)$$

where  $V_F$  is the diode's forward voltage drop, and  $D$  is the on-time duty cycle.

## FINAL CIRCUIT

The final circuit is shown in Figure 5, and its performance is shown in Figure 6 and Figure 7. The current limit measured approximately 1.62A at  $V_{\text{in}} = 8\text{V}$ , and 1.69A at  $V_{\text{in}} = 36\text{V}$ .

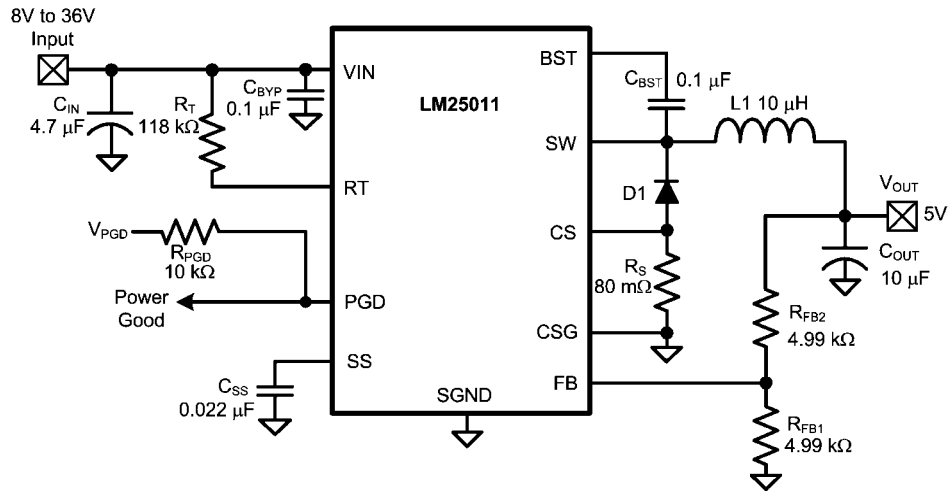

30094634

FIGURE 5. Example Circuit

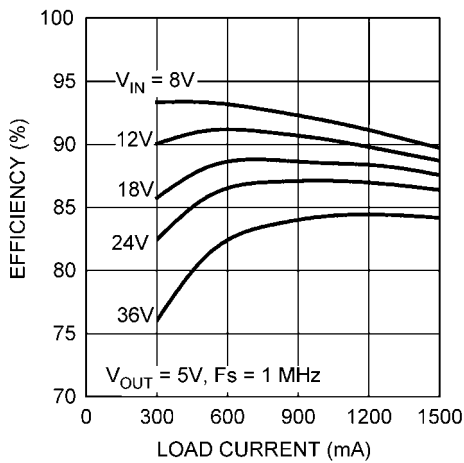

30094603

FIGURE 6. Efficiency (Circuit of Figure 5)

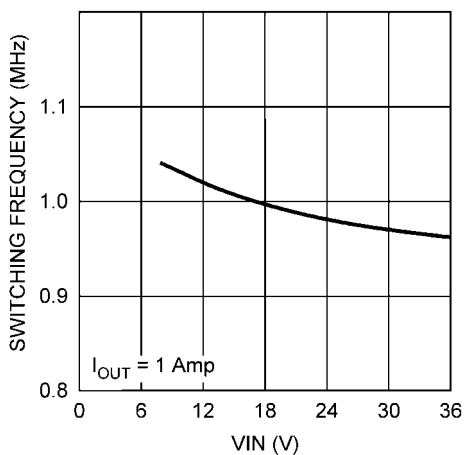

30094636

FIGURE 7. Frequency vs V<sub>IN</sub> (Circuit of Figure 5)

### PC BOARD LAYOUT

The LM25011 regulation and current limit comparators are very fast, and respond to short duration noise pulses. Layout considerations are therefore critical for optimum performance. The layout must be as neat and compact as possible, and all of the components must be as close as possible to their associated pins. The two major current loops conduct currents which switch very fast, and therefore those loops must be as small as possible to minimize conducted and radiated EMI. The first loop is formed by C<sub>IN</sub>, through the VIN to SW pins, L1, C<sub>OUT</sub>, and back to C<sub>IN</sub>. The second current loop is formed by R<sub>S</sub>, D1, L1, C<sub>OUT</sub> and back to R<sub>S</sub>. The ground connection from CSG to the ground end of C<sub>IN</sub> should be as short and direct as possible.

The power dissipation within the LM25011 can be approximated by determining the circuit's total conversion loss (P<sub>IN</sub> - P<sub>OUT</sub>), and then subtracting the power losses in the free-wheeling diode, the sense resistor, and the inductor. The power loss in the diode is approximately:

$$P_{D1} = I_{OUT} \times V_F \times (1-D)$$

where I<sub>OUT</sub> is the load current, V<sub>F</sub> is the diode's forward voltage drop, and D is the on-time duty cycle. The power loss in the sense resistor is:

$$P_{RS} = (I_{OUT})^2 \times R_S \times (1 - D)$$

The power loss in the inductor is approximately:

$$P_{L1} = I_{OUT}^2 \times R_L \times 1.1$$

where R<sub>L</sub> is the inductor's DC resistance, and the 1.1 factor is an approximation for the AC losses. If it is expected that the internal dissipation of the LM25011 will produce excessive junction temperatures during normal operation, good use of the PC board's ground plane can help to dissipate heat. Additionally the use of wide PC board traces, where possible, can help conduct heat away from the IC pins. Judicious positioning of the PC board within the end product, along with the use of any available air flow (forced or natural convection) can help reduce the junction temperature.



## Notes

For more National Semiconductor product information and proven design tools, visit the following Web sites at:

Products		Design Support	
Amplifiers	<a href="http://www.national.com/amplifiers">www.national.com/amplifiers</a>	WEBENCH® Tools	<a href="http://www.national.com/webench">www.national.com/webench</a>
Audio	<a href="http://www.national.com/audio">www.national.com/audio</a>	App Notes	<a href="http://www.national.com/appnotes">www.national.com/appnotes</a>
Clock and Timing	<a href="http://www.national.com/timing">www.national.com/timing</a>	Reference Designs	<a href="http://www.national.com/refdesigns">www.national.com/refdesigns</a>
Data Converters	<a href="http://www.national.com/adc">www.national.com/adc</a>	Samples	<a href="http://www.national.com/samples">www.national.com/samples</a>
Interface	<a href="http://www.national.com/interface">www.national.com/interface</a>	Eval Boards	<a href="http://www.national.com/evalboards">www.national.com/evalboards</a>
LVDS	<a href="http://www.national.com/lvds">www.national.com/lvds</a>	Packaging	<a href="http://www.national.com/packaging">www.national.com/packaging</a>
Power Management	<a href="http://www.national.com/power">www.national.com/power</a>	Green Compliance	<a href="http://www.national.com/quality/green">www.national.com/quality/green</a>
Switching Regulators	<a href="http://www.national.com/switchers">www.national.com/switchers</a>	Distributors	<a href="http://www.national.com/contacts">www.national.com/contacts</a>
LDOs	<a href="http://www.national.com/ldo">www.national.com/ldo</a>	Quality and Reliability	<a href="http://www.national.com/quality">www.national.com/quality</a>
LED Lighting	<a href="http://www.national.com/led">www.national.com/led</a>	Feedback/Support	<a href="http://www.national.com/feedback">www.national.com/feedback</a>
Voltage Reference	<a href="http://www.national.com/vref">www.national.com/vref</a>	Design Made Easy	<a href="http://www.national.com/easy">www.national.com/easy</a>
PowerWise® Solutions	<a href="http://www.national.com/powerwise">www.national.com/powerwise</a>	Solutions	<a href="http://www.national.com/solutions">www.national.com/solutions</a>
Serial Digital Interface (SDI)	<a href="http://www.national.com/sdi">www.national.com/sdi</a>	Mil/Aero	<a href="http://www.national.com/milaero">www.national.com/milaero</a>
Temperature Sensors	<a href="http://www.national.com/tempensors">www.national.com/tempensors</a>	SolarMagic™	<a href="http://www.national.com/solarmagic">www.national.com/solarmagic</a>
Wireless (PLL/VCO)	<a href="http://www.national.com/wireless">www.national.com/wireless</a>	PowerWise® Design University	<a href="http://www.national.com/training">www.national.com/training</a>

THE CONTENTS OF THIS DOCUMENT ARE PROVIDED IN CONNECTION WITH NATIONAL SEMICONDUCTOR CORPORATION ("NATIONAL") PRODUCTS. NATIONAL MAKES NO REPRESENTATIONS OR WARRANTIES WITH RESPECT TO THE ACCURACY OR COMPLETENESS OF THE CONTENTS OF THIS PUBLICATION AND RESERVES THE RIGHT TO MAKE CHANGES TO SPECIFICATIONS AND PRODUCT DESCRIPTIONS AT ANY TIME WITHOUT NOTICE. NO LICENSE, WHETHER EXPRESS, IMPLIED, ARISING BY ESTOPPEL OR OTHERWISE, TO ANY INTELLECTUAL PROPERTY RIGHTS IS GRANTED BY THIS DOCUMENT.

TESTING AND OTHER QUALITY CONTROLS ARE USED TO THE EXTENT NATIONAL DEEMS NECESSARY TO SUPPORT NATIONAL'S PRODUCT WARRANTY. EXCEPT WHERE MANDATED BY GOVERNMENT REQUIREMENTS, TESTING OF ALL PARAMETERS OF EACH PRODUCT IS NOT NECESSARILY PERFORMED. NATIONAL ASSUMES NO LIABILITY FOR APPLICATIONS ASSISTANCE OR BUYER PRODUCT DESIGN. BUYERS ARE RESPONSIBLE FOR THEIR PRODUCTS AND APPLICATIONS USING NATIONAL COMPONENTS. PRIOR TO USING OR DISTRIBUTING ANY PRODUCTS THAT INCLUDE NATIONAL COMPONENTS, BUYERS SHOULD PROVIDE ADEQUATE DESIGN, TESTING AND OPERATING SAFEGUARDS.

EXCEPT AS PROVIDED IN NATIONAL'S TERMS AND CONDITIONS OF SALE FOR SUCH PRODUCTS, NATIONAL ASSUMES NO LIABILITY WHATSOEVER, AND NATIONAL DISCLAIMS ANY EXPRESS OR IMPLIED WARRANTY RELATING TO THE SALE AND/OR USE OF NATIONAL PRODUCTS INCLUDING LIABILITY OR WARRANTIES RELATING TO FITNESS FOR A PARTICULAR PURPOSE, MERCHANTABILITY, OR INFRINGEMENT OF ANY PATENT, COPYRIGHT OR OTHER INTELLECTUAL PROPERTY RIGHT.

#### LIFE SUPPORT POLICY

**NATIONAL'S PRODUCTS ARE NOT AUTHORIZED FOR USE AS CRITICAL COMPONENTS IN LIFE SUPPORT DEVICES OR SYSTEMS WITHOUT THE EXPRESS PRIOR WRITTEN APPROVAL OF THE CHIEF EXECUTIVE OFFICER AND GENERAL COUNSEL OF NATIONAL SEMICONDUCTOR CORPORATION.** As used herein:

Life support devices or systems are devices which (a) are intended for surgical implant into the body, or (b) support or sustain life and whose failure to perform when properly used in accordance with instructions for use provided in the labeling can be reasonably expected to result in a significant injury to the user. A critical component is any component in a life support device or system whose failure to perform can be reasonably expected to cause the failure of the life support device or system or to affect its safety or effectiveness.

National Semiconductor and the National Semiconductor logo are registered trademarks of National Semiconductor Corporation. All other brand or product names may be trademarks or registered trademarks of their respective holders.

Copyright© 2009 National Semiconductor Corporation

For the most current product information visit us at [www.national.com](http://www.national.com)



**National Semiconductor**  
Americas Technical  
Support Center  
Email: [support@nsc.com](mailto:support@nsc.com)  
Tel: 1-800-272-9959

**National Semiconductor Europe**  
Technical Support Center  
Email: [europe.support@nsc.com](mailto:europe.support@nsc.com)

**National Semiconductor Asia**  
Pacific Technical Support Center  
Email: [ap.support@nsc.com](mailto:ap.support@nsc.com)

**National Semiconductor Japan**  
Technical Support Center  
Email: [jpn.feedback@nsc.com](mailto:jpn.feedback@nsc.com)