

DS08MB200

Dual 800 Mbps 2:1/1:2 LVDS Mux/Buffer

General Description

The DS08MB200 is a dual-port 1 to 2 repeater/buffer and 2 to 1 multiplexer. High-speed data paths and flow-through pinout minimize internal device jitter and simplify board layout. The differential inputs and outputs interface to LVDS or Bus LVDS signals such as those on National's 10-, 16-, and 18-bit Bus LVDS SerDes, or to CML or LVPECL signals.

The 3.3V supply, CMOS process, and robust I/O ensure high performance at low power over the entire industrial -40 to +85°C temperature range.

Features

- Up to 800 Mbps data rate per channel
- LVDS/BLVDS/CML/LVPECL compatible inputs, LVDS compatible outputs
- Low output skew and jitter
- On-chip 100Ω input termination
- 15 kV ESD protection on LVDS Inputs/Outputs
- Hot plug Protection
- Single 3.3V supply
- Industrial -40 to +85°C temperature range
- 48-pin LLP Package

Typical Application

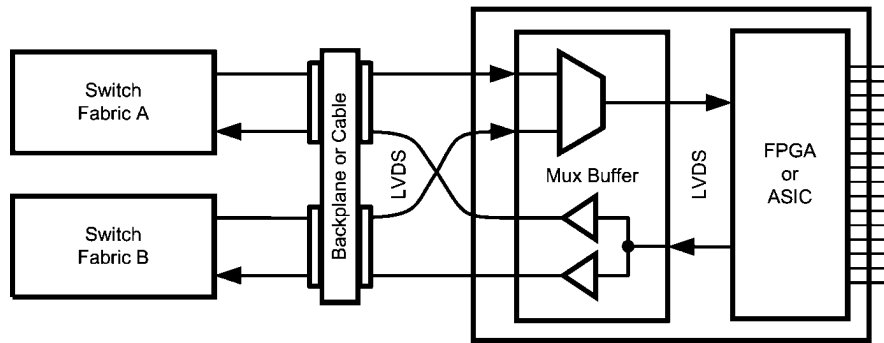

20157420

Block Diagram

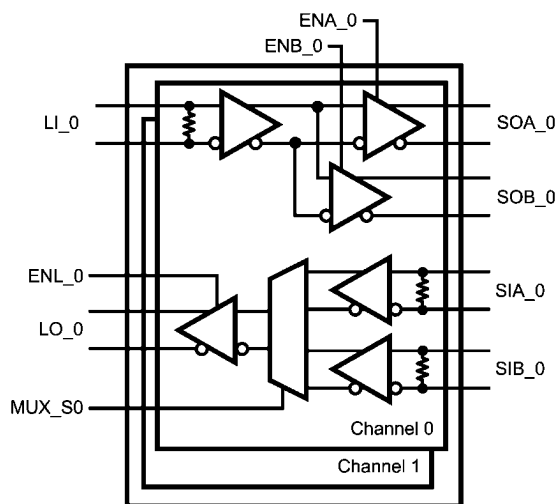

20157401

FIGURE 1. DS08MB200 Block Diagram

Pin Descriptions

Pin Name	LLP Pin Number	I/O, Type	Description
SWITCH SIDE DIFFERENTIAL INPUTS			
SIA_0+ SIA_0-	30 29	I, LVDS	Switch A-side Channel 0 inverting and non-inverting differential inputs. LVDS, Bus LVDS, CML, or LVPECL compatible.
SIA_1+ SIA_1-	19 20	I, LVDS	Switch A-side Channel 1 inverting and non-inverting differential inputs. LVDS, Bus LVDS, CML, or LVPECL compatible.
SIB_0+ SIB_0-	28 27	I, LVDS	Switch B-side Channel 0 inverting and non-inverting differential inputs. LVDS, Bus LVDS, CML, or LVPECL compatible.
SIB_1+ SIB_1-	21 22	I, LVDS	Switch B-side Channel 1 inverting and non-inverting differential inputs. LVDS, Bus LVDS, CML, or LVPECL compatible.
LINE SIDE DIFFERENTIAL INPUTS			
LI_0+ LI_0-	40 39	I, LVDS	Line-side Channel 0 inverting and non-inverting differential inputs. LVDS, Bus LVDS, CML, or LVPECL compatible.
LI_1+ LI_1-	9 10	I, LVDS	Line-side Channel 1 inverting and non-inverting differential inputs. LVDS, Bus LVDS, CML, or LVPECL compatible.
SWITCH SIDE DIFFERENTIAL OUTPUTS			
SOA_0+ SOA_0-	34 33	O, LVDS	Switch A-side Channel 0 inverting and non-inverting differential outputs. LVDS compatible (Notes 1, 3).
SOA_1+ SOA_1-	15 16	O, LVDS	Switch A-side Channel 1 inverting and non-inverting differential outputs. LVDS compatible (Notes 1, 3).
SOB_0+ SOB_0-	32 31	O, LVDS	Switch B-side Channel 0 inverting and non-inverting differential outputs. LVDS compatible (Notes 1, 3).
SOB_1+ SOB_1-	17 18	O, LVDS	Switch B-side Channel 1 inverting and non-inverting differential outputs. LVDS compatible (Notes 1, 3).
LINE SIDE DIFFERENTIAL OUTPUTS			
LO_0+ LO_0-	42 41	O, LVDS	Line-side Channel 0 inverting and non-inverting differential outputs. LVDS compatible (Notes 1, 3).
LO_1+ LO_1-	7 8	O, LVDS	Line-side Channel 1 inverting and non-inverting differential outputs. LVDS compatible (Notes 1, 3).
DIGITAL CONTROL INTERFACE			
MUX_S0 MUX_S1	38 11	I, LVTTTL	Mux Select Control Inputs (per channel) to select which Switch-side input, A or B, is passed through to the Line-side.
ENA_0 ENA_1 ENB_0 ENB_1	36 13 35 14	I, LVTTTL	Output Enable Control for Switch A-side and B-side outputs. Each output driver on the A-side and B-side has a separate enable pin.
ENL_0 ENL_1	45 4	I, LVTTTL	Output Enable Control for The Line-side outputs. Each output driver on the Line-side has a separate enable pin.
POWER			
V _{DD}	6, 12, 37, 43, 48	I, Power	V _{DD} = 3.3V ±0.3V.
GND	2, 3, 46, 47 (Note 2)	I, Power	Ground reference for LVDS and CMOS circuitry. For the LLP package, the DAP is used as the primary GND connection to the device. The DAP is the exposed metal contact at the bottom of the LLP-48 package. It should be connected to the ground plane with at least 4 vias for optimal AC and thermal performance.
N/C	1, 5, 23, 24, 25, 26, 44		No Connect

Note 1: For interfacing LVDS outputs to CML or LVPECL compatible inputs, refer to the applications section of this datasheet.

Note 2: Note that the DAP on the backside of the LLP package is the primary GND connection for the device when using the LLP package.

Note 3: The LVDS outputs do not support a multidrop (BLVDS) environment. The LVDS output characteristics of the DS08MB200 device have been optimized for point-to-point backplane and cable applications.

Connection Diagrams

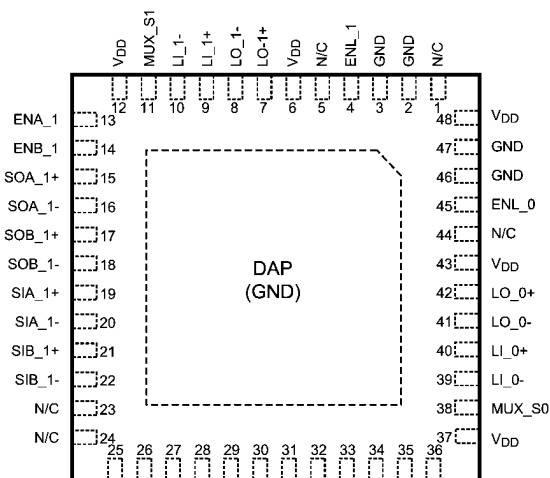

Top View
DAP = GND

20157402

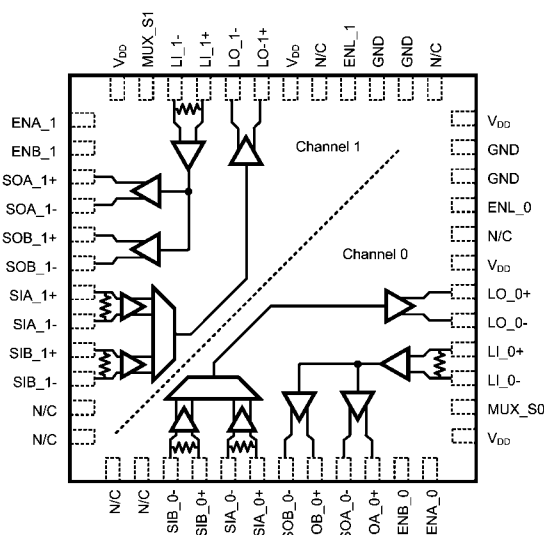

Directional Signal Paths Top View
(Refer to pin names for signal polarity)

20157403

TRI-STATE and Powerdown Modes

The DS08MB200 has output enable control on each of the six onboard LVDS output drivers. This control allows each output individually to be placed in a low power TRI-STATE mode while the device remains active, and is useful to reduce power consumption on unused channels. In TRI-STATE mode, some outputs may remain active while some are in TRI-STATE.

When all six of the output enables (all drivers on both channels) are deasserted (LOW), then the device enters a Powerdown mode that consumes only 0.5mA (typical) of supply current. In this mode, the entire device is essentially powered off, including all receiver inputs, output drivers and internal bandgap reference generators. When returning to active mode from Powerdown mode, there is a delay until valid data is presented at the outputs because of the ramp to power up the internal bandgap reference generators.

Any single output enable that remains active will hold the device in active mode even if the other five outputs are in TRI-STATE.

When in Powerdown mode, any output enable that becomes active will wake up the device back into active mode, even if the other five outputs are in TRI-STATE.

Input Failsafe Biasing

External pull up and pull down resistors may be used to provide enough of an offset to enable an input failsafe under open-circuit conditions. This configuration ties the positive LVDS input pin to VDD thru a pull up resistor and the negative LVDS input pin is tied to GND by a pull down resistor. The pull up and pull down resistors should be in the 5kΩ to 15kΩ range to minimize loading and waveform distortion to the driver. Please refer to application note AN-1194, "Failsafe Biasing of LVDS Interfaces" for more information.

Output Characteristics

The output characteristics of the DS08MB200 have been optimized for point-to-point backplane and cable applications, and are not intended for multipoint or multidrop signaling.

Multiplexer Truth Table (Note 4)

Data Inputs		Control Inputs		Output
SIA_0	SIB_0	MUX_S0	ENL_0	LO_0
X	valid	0	1	SIB_0
valid	X	1	1	SIA_0
X	X	X	0 (Note 5)	Z

X = Don't Care

Z = High Impedance (TRI-STATE)

Repeater/Buffer Truth Table (Note 4)

Data Input	Control Inputs		Outputs	
LI_0	ENA_0	ENB_0	SOA_0	SOB_0
X	0	0	Z (Note 5)	Z (Note 5)
valid	0	1	Z	LI_0
valid	1	0	LI_0	Z
valid	1	1	LI_0	LI_0

X = Don't Care

Z = High Impedance (TRI-STATE)

Note 4: Same functionality for channel 1

Note 5: When all enable inputs from both channels are Low, the device enters a powerdown mode. Refer to the applications section titled TRI-STATE and Powerdown modes.

Absolute Maximum Ratings (Note 6)

Supply Voltage (V_{DD})	-0.3V to +4.0V
CMOS Input Voltage	-0.3V to ($V_{DD}+0.3V$)
LVDS Receiver Input Voltage (Note 7)	-0.3V to ($V_{DD}+0.3V$)
LVDS Driver Output Voltage	-0.3V to ($V_{DD}+0.3V$)
LVDS Output Short Circuit Current	+40 mA
Junction Temperature	+150°C
Storage Temperature	-65°C to +150°C
Lead Temperature (Solder, 4sec)	260°C
Max Pkg Power Capacity @ 25°C	5.2W
Thermal Resistance (θ_{JA})	24°C/W
Package Derating above +25°C	41.7mW/°C
ESD Last Passing Voltage	
HBM, 1.5k Ω , 100pF	8kV
LVDS pins to GND only	15kV

EIAJ, 0 Ω , 200pF
CDM250V
1000V**Recommended Operating Conditions**

Supply Voltage (V_{CC})	3.0V to 3.6V
Input Voltage (V_I) (Note 7)	0V to V_{CC}
Output Voltage (V_O)	0V to V_{CC}
Operating Temperature (T_A)	
Industrial	-40°C to +85°C

Note 6: Absolute maximum ratings are those values beyond which damage to the device may occur. The databook specifications should be met, without exception, to ensure that the system design is reliable over its power supply, temperature, and output/input loading variables. National does not recommend operation of products outside of recommended operation conditions.

Note 7: V_{ID} max < 2.4V

Electrical Characteristics

Over recommended operating supply and temperature ranges unless other specified.

Symbol	Parameter	Conditions	Min	Typ (Note 8)	Max	Units
LVTTL DC SPECIFICATIONS (MUX_Sn, ENA_n, ENB_n, ENL_n)						
V_{IH}	High Level Input Voltage		2.0		V_{DD}	V
V_{IL}	Low Level Input Voltage		GND		0.8	V
I_{IH}	High Level Input Current	$V_{IN} = V_{DD} = V_{DDMAX}$	-10		+10	μ A
I_{IL}	Low Level Input Current	$V_{IN} = V_{SS}, V_{DD} = V_{DDMAX}$	-10		+10	μ A
C_{IN1}	Input Capacitance	Any Digital Input Pin to V_{SS}		3.5		pF
C_{OUT1}	Output Capacitance	Any Digital Output Pin to V_{SS}		5.5		pF
V_{CL}	Input Clamp Voltage	$I_{CL} = -18$ mA	-1.5	-0.8		V
LVDS INPUT DC SPECIFICATIONS (SIA \pm , SIB \pm , LI \pm)						
V_{TH}	Differential Input High Threshold (Note 9)	$V_{CM} = 0.8V$ or 1.2V or 3.55V, $V_{DD} = 3.6V$		0	100	mV
V_{TL}	Differential Input Low Threshold (Note 9)	$V_{CM} = 0.8V$ or 1.2V or 3.55V, $V_{DD} = 3.6V$	-100	0		mV
V_{ID}	Differential Input Voltage	$V_{CM} = 0.8V$ to 3.55V, $V_{DD} = 3.6V$	100		2400	mV
V_{CMR}	Common Mode Voltage Range	$V_{ID} = 150$ mV, $V_{DD} = 3.6V$	0.05		3.55	V
C_{IN2}	Input Capacitance	IN+ or IN- to V_{SS}		3.5		pF
I_{IN}	Input Current	$V_{IN} = 3.6V, V_{DD} = V_{DDMAX}$	-15		+15	μ A
		$V_{IN} = 0V, V_{DD} = V_{DDMAX}$	-15		+15	μ A
LVDS OUTPUT DC SPECIFICATIONS (SOA_n \pm , SOB_n \pm , LO_n \pm)						
V_{OD}	Differential Output Voltage, (Note 9)	R_L is the internal 100 Ω between OUT+ and OUT-	250	360	500	mV
ΔV_{OD}	Change in V_{OD} between Complementary States		-35		35	mV
V_{OS}	Offset Voltage (Note 10)		1.05	1.22	1.475	V
ΔV_{OS}	Change in V_{OS} between Complementary States		-35		35	mV
I_{OS}	Output Short Circuit Current	OUT+ or OUT- Short to GND		-21	-40	mA
C_{OUT2}	Output Capacitance	OUT+ or OUT- to GND when TRI-STATE		5.5		pF

Symbol	Parameter	Conditions	Min	Typ (Note 8)	Max	Units
SUPPLY CURRENT (Static)						
I_{CC}	Supply Current	All inputs and outputs enabled and active, terminated with differential load of 100Ω between OUT+ and OUT-.		225	275	mA
I_{CCZ}	Supply Current - Powerdown Mode	ENA_0 = ENB_0 = ENL_0 = ENA_1 = ENB_1 = ENL_1 = L		0.6	4.0	mA
SWITCHING CHARACTERISTICS—LVDS OUTPUTS						
t_{LHT}	Differential Low to High Transition Time	Use an alternating 1 and 0 pattern at 200 Mb/s, measure between 20% and 80% of V_{OD} . (Note 15)		170	250	ps
t_{HLT}	Differential High to Low Transition Time			170	250	ps
t_{PLHD}	Differential Low to High Propagation Delay	Use an alternating 1 and 0 pattern at 200 Mb/s, measure at 50% V_{OD} between input to output.		1.0	2.5	ns
t_{PHLD}	Differential High to Low Propagation Delay			1.0	2.5	ns
t_{SKD1}	Pulse Skew	$ t_{PLHD} - t_{PHLD} $ (Note 15)		25	75	ps
t_{SKCC}	Output Channel to Channel Skew	Difference in propagation delay (t_{PLHD} or t_{PHLD}) among all output channels. (Note 15)		50	115	ps
t_{JIT}	Jitter (Note 11)	RJ - Alternating 1 and 0 at 400 MHz (Note 12)		1.3	1.5	psrms
		DJ - K28.5 Pattern, 800 Mbps (Note 13)		15	34	psp-p
		TJ - PRBS 27-1 Pattern, 800 Mbps (Note 14)		16	34	psp-p
t_{ON}	LVDS Output Enable Time	Time from ENA_n, ENB_n, or ENL_n to OUT± change from TRI-STATE to active.		0.5	1.5	μs
t_{ON2}	LVDS Output Enable time from powerdown mode	Time from ENA_n, ENB_n, or ENL_n to OUT± change from Powerdown to active		10	20	μs
t_{OFF}	LVDS Output Disable Time	Time from ENA_n, ENB_n, or ENL_n to OUT± change from active to TRI-STATE or powerdown.			12	ns

Note 8: Typical parameters are measured at $V_{DD} = 3.3V$, $T_A = 25^\circ C$. They are for reference purposes, and are not production-tested.

Note 9: Differential output voltage V_{OD} is defined as $ABS(OUT+ - OUT-)$. Differential input voltage V_{ID} is defined as $ABS(IN+ - IN-)$.

Note 10: Output offset voltage V_{OS} is defined as the average of the LVDS single-ended output voltages at logic high and logic low states.

Note 11: Jitter is not production tested, but guaranteed through characterization on a sample basis.

Note 12: Random Jitter, or RJ, is measured RMS with a histogram including 1500 histogram window hits. The input voltage = $V_{ID} = 500mV$, 50% duty cycle at 400 MHz, $t_r = t_f = 50ps$ (20% to 80%).

Note 13: Deterministic Jitter, or DJ, is measured to a histogram mean with a sample size of 350 hits. Stimulus and fixture jitter has been subtracted. The input voltage = $V_{ID} = 500mV$, K28.5 pattern at 800 Mbps, $t_r = t_f = 50ps$ (20% to 80%). The K28.5 pattern is repeating bit streams of (0011111010 110000101).

Note 14: Total Jitter, or TJ, is measured peak to peak with a histogram including 3500 window hits. Stimulus and fixture jitter has been subtracted. The input voltage = $V_{ID} = 500mV$, 27-1 PRBS pattern at 800 Mbps, $t_r = t_f = 50ps$ (20% to 80%).

Note 15: Not production tested. Guaranteed by statistical analysis on a sample basis at the time of characterization.

Typical Performance Characteristics

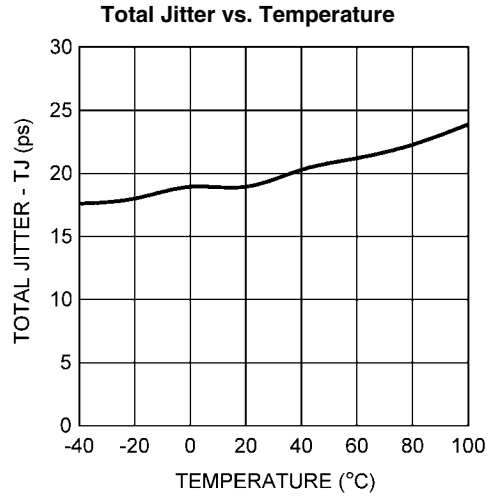
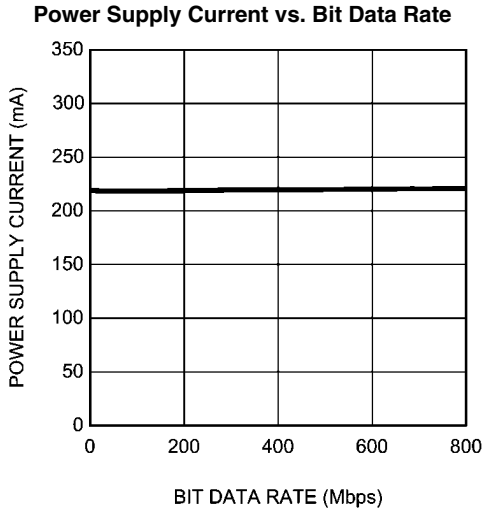

20157412
 Dynamic power supply current was measured with all channels active and toggling at the bit data rate. Data pattern has no effect on the power consumption. $V_{DD} = 3.3V$, $T_A = +25^\circ C$, $V_{ID} = 0.5V$, $V_{CM} = 1.2V$.

20157410
 Total Jitter measured at 0V differential while running a PRBS 2^{7-1} pattern with one channel active, all other channels are disabled. $V_{DD} = 3.3V$, $V_{ID} = 0.5V$, $V_{CM} = 1.2V$, 800 Mbps data rate. Stimulus and fixture jitter has been subtracted.

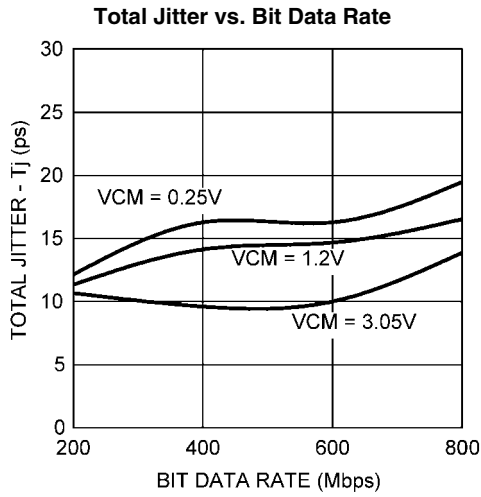

20157411
 Total Jitter measured at 0V differential while running a PRBS 2^{7-1} pattern with one channel active, all other channels are disabled. $V_{DD} = 3.3V$, $T_A = +25^\circ C$, $V_{ID} = 0.5V$. Stimulus and fixture jitter has been subtracted.

Interfacing LVPECL to LVDS

An LVPECL driver consists of a differential pair with coupled emitters connected to GND via a current source. This drives a pair of emitter-followers that require a 50 ohm to $V_{CC}-2.0$ load. A modern LVPECL driver will typically include the termination scheme within the device for the emitter follower. If the driver does not include the load, then an external scheme must be used. The 1.3 V supply is usually not readily available on a PCB, therefore, a load scheme without a unique power supply requirement may be used.

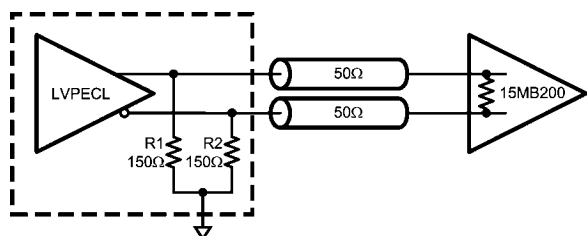

20157461

FIGURE 2. DC Coupled LVPECL to LVDS Interface

Figure 2 is a separated π termination scheme for a 3.3 V LVPECL driver. R1 and R2 provides proper DC load for the driver emitter followers, and may be included as part of the driver device (Note 16). The DS08MB200 includes a 100 ohm input termination for the transmission line. The common mode voltage will be at the normal LVPECL levels – around 2 V. This scheme works well with LVDS receivers that have rail-to-rail common mode voltage, V_{CM} , range. Most National Semiconductor LVDS receivers have wide V_{CM} range. The exceptions are noted in devices' respective datasheets. Those LVDS devices that do have a wide V_{CM} range do not vary in performance significantly when receiving a signal with a common mode other than standard LVDS V_{CM} of 1.2 V.

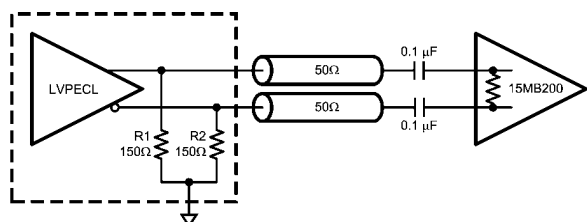

20157462

FIGURE 3. AC Coupled LVPECL to LVDS Interface

An AC coupled interface is preferred when transmitter and receiver ground references differ more than 1 V. This is a likely scenario when transmitter and receiver devices are on separate PCBs. Figure 3 illustrates an AC coupled interface between a LVPECL driver and LVDS receiver. R1 and R2, if not present in the driver device (Note 16), provide DC load for the emitter followers and may range between 140-220 ohms for most LVPECL devices for this particular configuration. The DS08MB200 includes an internal 100 ohm resistor to terminate the transmission line for minimal reflections. The signal after ac coupling capacitors will swing around a level set by internal biasing resistors (i.e. fail-safe) which is either $V_{DD}/2$ or 0 V depending on the actual failsafe implementation. If internal biasing is not implemented, the signal common mode voltage will slowly wander to GND level.

Interfacing LVDS to LVPECL

An LVDS driver consists of a current source (nominal 3.5mA) which drives a CMOS differential pair. It needs a differential resistive load in the range of 70 to 130 ohms to generate LVDS levels. In a system, the load should be selected to match transmission line characteristic differential impedance so that the line is properly terminated. The termination resistor should be placed as close to the receiver inputs as possible. When interfacing an LVDS driver with a non-LVDS receiver, one only needs to bias the LVDS signal so that it is within the common mode range of the receiver. This may be done by using separate biasing voltage which demands another power supply. Some receivers have required biasing voltage available on-chip (V_T , V_{TT} or V_{BB}).

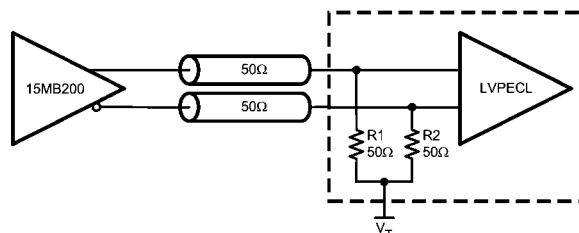

20157463

FIGURE 4. DC Coupled LVDS to LVPECL Interface

Figure 4 illustrates interface between an LVDS driver and a LVPECL with a V_T pin available. R1 and R2, if not present in the receiver (Note 16), provide proper resistive load for the driver and termination for the transmission line, and V_T sets desired bias for the receiver.

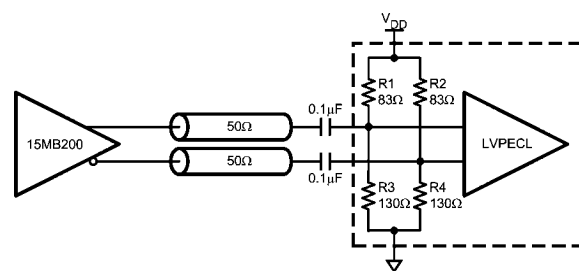

20157464

FIGURE 5. AC Coupled LVDS to LVPECL Interface

Figure 5 illustrates AC coupled interface between an LVDS driver and LVPECL receiver without a V_T pin available. The resistors R1, R2, R3, and R4, if not present in the receiver (Note 16), provide a load for the driver, terminate the transmission line, and bias the signal for the receiver.

Note 16: The bias networks shown above for LVPECL drivers and receivers may or may not be present within the driver device. The LVPECL driver and receiver specification must be reviewed closely to ensure compatibility between the driver and receiver terminations and common mode operating ranges.

Notes

Notes

For more National Semiconductor product information and proven design tools, visit the following Web sites at:

Products		Design Support	
Amplifiers	www.national.com/amplifiers	WEBENCH	www.national.com/webench
Audio	www.national.com/audio	Analog University	www.national.com/AU
Clock Conditioners	www.national.com/timing	App Notes	www.national.com/appnotes
Data Converters	www.national.com/adc	Distributors	www.national.com/contacts
Displays	www.national.com/displays	Green Compliance	www.national.com/quality/green
Ethernet	www.national.com/ethernet	Packaging	www.national.com/packaging
Interface	www.national.com/interface	Quality and Reliability	www.national.com/quality
LVDS	www.national.com/lvds	Reference Designs	www.national.com/refdesigns
Power Management	www.national.com/power	Feedback	www.national.com/feedback
Switching Regulators	www.national.com/switchers		
LDOs	www.national.com/ldo		
LED Lighting	www.national.com/led		
PowerWise	www.national.com/powerwise		
Serial Digital Interface (SDI)	www.national.com/sdi		
Temperature Sensors	www.national.com/tempsensors		
Wireless (PLL/VCO)	www.national.com/wireless		

THE CONTENTS OF THIS DOCUMENT ARE PROVIDED IN CONNECTION WITH NATIONAL SEMICONDUCTOR CORPORATION ("NATIONAL") PRODUCTS. NATIONAL MAKES NO REPRESENTATIONS OR WARRANTIES WITH RESPECT TO THE ACCURACY OR COMPLETENESS OF THE CONTENTS OF THIS PUBLICATION AND RESERVES THE RIGHT TO MAKE CHANGES TO SPECIFICATIONS AND PRODUCT DESCRIPTIONS AT ANY TIME WITHOUT NOTICE. NO LICENSE, WHETHER EXPRESS, IMPLIED, ARISING BY ESTOPPEL OR OTHERWISE, TO ANY INTELLECTUAL PROPERTY RIGHTS IS GRANTED BY THIS DOCUMENT.

TESTING AND OTHER QUALITY CONTROLS ARE USED TO THE EXTENT NATIONAL DEEMS NECESSARY TO SUPPORT NATIONAL'S PRODUCT WARRANTY. EXCEPT WHERE MANDATED BY GOVERNMENT REQUIREMENTS, TESTING OF ALL PARAMETERS OF EACH PRODUCT IS NOT NECESSARILY PERFORMED. NATIONAL ASSUMES NO LIABILITY FOR APPLICATIONS ASSISTANCE OR BUYER PRODUCT DESIGN. BUYERS ARE RESPONSIBLE FOR THEIR PRODUCTS AND APPLICATIONS USING NATIONAL COMPONENTS. PRIOR TO USING OR DISTRIBUTING ANY PRODUCTS THAT INCLUDE NATIONAL COMPONENTS, BUYERS SHOULD PROVIDE ADEQUATE DESIGN, TESTING AND OPERATING SAFEGUARDS.

EXCEPT AS PROVIDED IN NATIONAL'S TERMS AND CONDITIONS OF SALE FOR SUCH PRODUCTS, NATIONAL ASSUMES NO LIABILITY WHATSOEVER, AND NATIONAL DISCLAIMS ANY EXPRESS OR IMPLIED WARRANTY RELATING TO THE SALE AND/OR USE OF NATIONAL PRODUCTS INCLUDING LIABILITY OR WARRANTIES RELATING TO FITNESS FOR A PARTICULAR PURPOSE, MERCHANTABILITY, OR INFRINGEMENT OF ANY PATENT, COPYRIGHT OR OTHER INTELLECTUAL PROPERTY RIGHT.

LIFE SUPPORT POLICY

NATIONAL'S PRODUCTS ARE NOT AUTHORIZED FOR USE AS CRITICAL COMPONENTS IN LIFE SUPPORT DEVICES OR SYSTEMS WITHOUT THE EXPRESS PRIOR WRITTEN APPROVAL OF THE CHIEF EXECUTIVE OFFICER AND GENERAL COUNSEL OF NATIONAL SEMICONDUCTOR CORPORATION. As used herein:

Life support devices or systems are devices which (a) are intended for surgical implant into the body, or (b) support or sustain life and whose failure to perform when properly used in accordance with instructions for use provided in the labeling can be reasonably expected to result in a significant injury to the user. A critical component is any component in a life support device or system whose failure to perform can be reasonably expected to cause the failure of the life support device or system or to affect its safety or effectiveness.

National Semiconductor and the National Semiconductor logo are registered trademarks of National Semiconductor Corporation. All other brand or product names may be trademarks or registered trademarks of their respective holders.

Copyright© 2007 National Semiconductor Corporation

For the most current product information visit us at www.national.com



**National Semiconductor
Americas Customer
Support Center**
Email:
new.feedback@nsc.com
Tel: 1-800-272-9959

**National Semiconductor Europe
Customer Support Center**
Fax: +49 (0) 180-530-85-86
Email: europe.support@nsc.com
Deutsch Tel: +49 (0) 69 9508 6208
English Tel: +49 (0) 870 24 0 2171
Français Tel: +33 (0) 1 41 91 8790

**National Semiconductor Asia
Pacific Customer Support Center**
Email: ap.support@nsc.com

**National Semiconductor Japan
Customer Support Center**
Fax: 81-3-5639-7507
Email: jpn.feedback@nsc.com
Tel: 81-3-5639-7560