



Power over Ethernet Consortium

Clause 33 PD Conformance Test Suite v 1.5 Report

UNH-IOL — 121 Technology Drive, Suite 2 — Durham, NH 03824 — (603) 862-0090
Consortium Manager: Gerard Nadeau — grn@iol.unh.edu — (603) 862-0116

Joseph DeNicholas
National Semiconductor
15210 South 50th St
Pheonix, AZ 85044

March 16, 2006
Report Rev. 1.0

Enclosed are the results from the Clause 33 PD Conformance testing performed on:

Device Under Test (DUT):	National Semiconductor LM5072
Hardware Version:	Not Available
DUT PHY Chip:	Not Applicable
Power Chipset:	National Semiconductor
DUT Magnetics:	Coilcraft DA2257-AL

The test suite referenced in this report is available at the UNH-IOL website:

ftp://ftp.iol.unh.edu/pub/ethernet/test_suites/CL33_PD/PD_Test_Suite_v1.5.pdf

There were no issues observed during testing.

Testing Completed 03/16/2006

Review Completed 03/16/2006

A handwritten signature in black ink that reads "Matthew F Borowski".

A handwritten signature in black ink that reads "Dave Schwarzenberg".

Matthew Borowski
mfn6@iol.unh.edu

Dave Schwarzenberg
dws2@iol.unh.edu

Digital Signature Information

This document was created using an Adobe digital signature. A digital signature helps to ensure the authenticity of the document, but only in this digital format. For information on how to verify this document's integrity proceed to the following site:

<http://www.iol.unh.edu/certifyDoc>

If the document status still indicates "Validity of author NOT confirmed", then please contact the UNH-IOL to confirm the document's authenticity. To further validate the certificate integrity, Adobe 6.0 should report the following fingerprint information:

MD5 Fingerprint: A569 F807 031D B1EC E509 4110 95E3 5362
SHA-1 Fingerprint: F007 7D91 2FAA A22C A3D9 F93F 05AC 09DB E219 84B2

Result Key

The following table contains possible results and their meanings:

Result	Interpretation
PASS	The Device Under Test (DUT) was observed to exhibit conformant behavior.
PASS with Comments	The DUT was observed to exhibit conformant behavior however an additional explanation of the situation is included, such as due to time limitations only a portion of the testing was performed.
FAIL	The DUT was observed to exhibit non-conformant behavior.
Warning	The DUT was observed to exhibit behavior that is not recommended.
Informative	Results are for informative purposes only and are not judged on a pass or fail basis.
Refer to Comments	From the observations, a valid pass or fail could not be determined. An additional explanation of the situation is included.
Not Applicable	The DUT does not support the technology required to perform these tests.
Not Available	Due to testing station or time limitations, the tests could not be performed.
Borderline	The observed values of the specified parameters are valid at one extreme, and invalid at the other.
Not Tested	Not tested due to the time constraints of the test period.

Test Setup

Testing Equipment	
Testing Software	UNH-IOL PDGUI_v2.2
Real-time DSO	TEKTRONIX, TDS 3014
Current Probe and Amplifier	TEKTRONIX, TPS305 and TPSA300
Digital Multimeter	HEWLETT-PACKARD, 34401A
Digital Power Supply	AGILENT TECHNOLOGIES, E3641A

Testing Configuration A

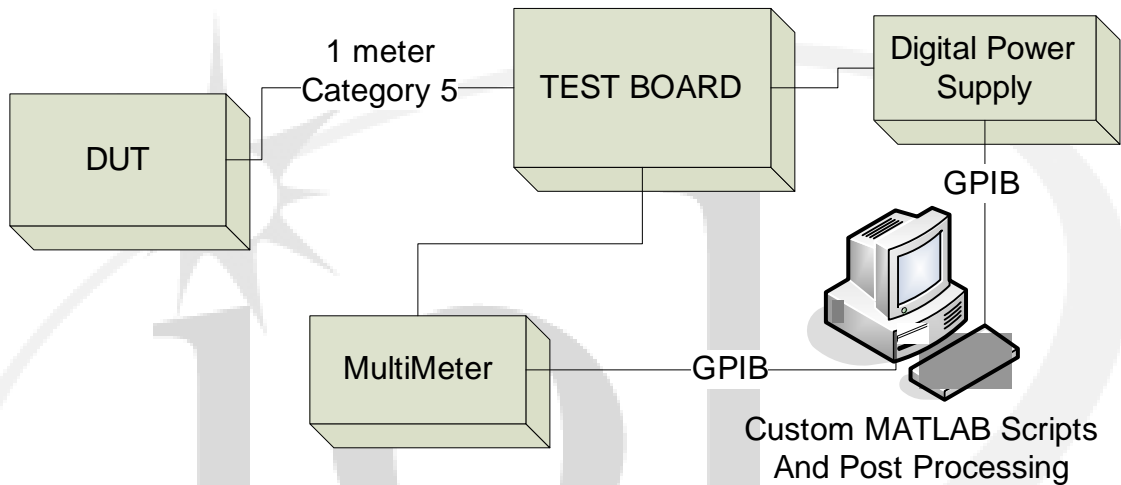

Testing Configuration B

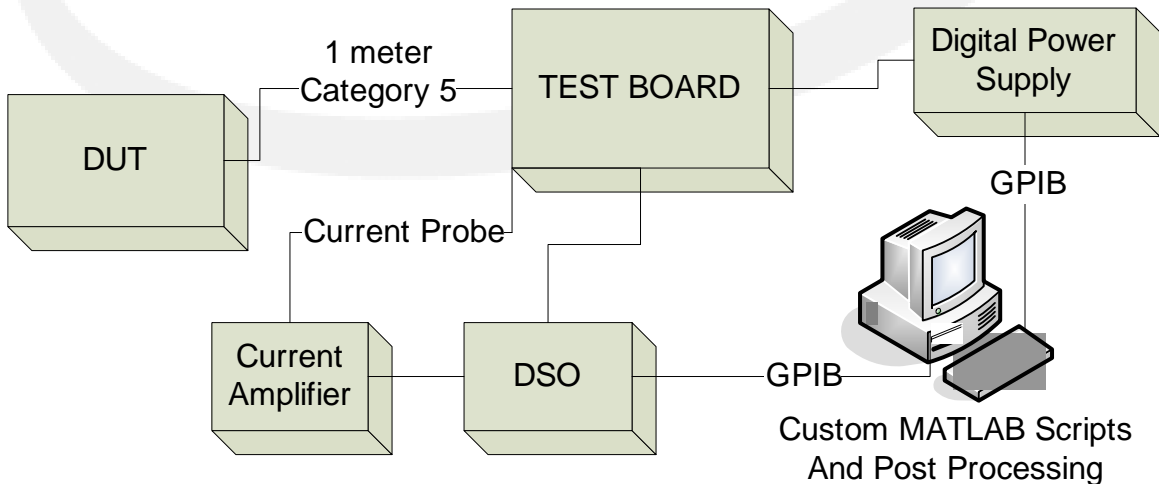

GROUP 1: PARAMETRIC TESTING

Test # and Label	Part(s)	Result(s)
33.1.1 – PD Source Power	a	PASS
Expected Results and Procedural Comments		
<p>Using Testing Configuration A, verify that the DUT does not source power on its PI for either mode A and B.</p> <p>a. The DUT should not source power on its PI at any time.</p>		
Comments on Test Results		
<p>a. The DUT was observed to not source power on either of its two sets of PI conductors.</p>		

Test # and Label	Part(s)	Result(s)
33.1.2 – PD Pinout	a	PASS
Expected Results and Procedural Comments		
<p>Using Testing Configuration A, verify that the DUT is insensitive to the polarity of the power supply and is able to operate in either Mode A or Mode B.</p> <p>a. In all cases the DUT should accept the applied power and become operational once the requested power has been supplied.</p>		
Comments on Test Results		
<p>a. The DUT became operational when power was applied to Mode A (MDI and MDI-X), or Mode B (MDI and MDI-X).</p>		

Clause 33 PD Conformance Test Suite v1.5 Report
DUT: National Semiconductor LM5072

Test # and Label	Part(s)	Result(s)																													
33.1.3 Valid PD Detection Signature	a	PASS																													
	b	PASS																													
Expected Results and Procedural Comments																															
<p>Purpose: To verify that the DUT presents a valid detection signature while it is requesting power on the PI.</p> <p>a. The observed signature resistance should be between 23.75 and 26.25 kΩ (inclusive).</p> <p>b. The DUT should have either a voltage offset less than or equal to 1.9 V, or a current offset less than or equal to 10 μA.</p>																															
Comments on Test Results																															
<table border="1" style="width: 100%; border-collapse: collapse;"> <thead> <tr> <th style="background-color: #ffcc99;">Part a.</th> <th style="background-color: #ffcc99;">Mode A</th> <th style="background-color: #ffcc99;">Mode B</th> <th style="background-color: #ffcc99;">Units</th> </tr> </thead> <tbody> <tr> <td>V-I Slope Minimum</td> <td style="text-align: center;">24.970</td> <td style="text-align: center;">24.965</td> <td style="text-align: center;">KΩ</td> </tr> <tr> <td>V-I Slope Average</td> <td style="text-align: center;">25.235</td> <td style="text-align: center;">25.214</td> <td style="text-align: center;">KΩ</td> </tr> <tr> <td>V-I Slope Maximum</td> <td style="text-align: center;">25.592</td> <td style="text-align: center;">25.585</td> <td style="text-align: center;">KΩ</td> </tr> <tr> <th style="background-color: #ffcc99;">Part b.</th> <td></td> <td></td> <td></td> </tr> <tr> <td>Voltage Offset</td> <td style="text-align: center;">0.910</td> <td style="text-align: center;">0.915</td> <td style="text-align: center;">V</td> </tr> <tr> <td>Current Offset</td> <td style="text-align: center;">Not Applicable</td> <td style="text-align: center;">Not Applicable</td> <td style="text-align: center;">μA</td> </tr> </tbody> </table> <p>NOTE: Failures indicated in red, enclosed by parenthesis</p>				Part a.	Mode A	Mode B	Units	V-I Slope Minimum	24.970	24.965	KΩ	V-I Slope Average	25.235	25.214	KΩ	V-I Slope Maximum	25.592	25.585	KΩ	Part b.				Voltage Offset	0.910	0.915	V	Current Offset	Not Applicable	Not Applicable	μA
Part a.	Mode A	Mode B	Units																												
V-I Slope Minimum	24.970	24.965	KΩ																												
V-I Slope Average	25.235	25.214	KΩ																												
V-I Slope Maximum	25.592	25.585	KΩ																												
Part b.																															
Voltage Offset	0.910	0.915	V																												
Current Offset	Not Applicable	Not Applicable	μA																												

Test # and Label	Part(s)	Result(s)													
33.1.4 – Non Valid PD Detection Signature	a	PASS													
Expected Results and Procedural Comments															
<p>Purpose: To verify that the DUT presents a non-valid detection signature while it is not requesting power, or once powered, at the PI of the non-powered pairs.</p> <p>a. The PD should have a non-valid input resistance less than 12 kΩ or greater than 45 kΩ..</p>															
Comments on Test Results															
<table border="1" style="width: 100%; border-collapse: collapse;"> <thead> <tr> <th style="background-color: #ffcc99;">Part a.</th> <th style="background-color: #ffcc99;">Mode A</th> <th style="background-color: #ffcc99;">Mode B</th> <th style="background-color: #ffcc99;">Units</th> </tr> </thead> <tbody> <tr> <td>V-I Slope Minimum</td> <td style="text-align: center;">6457.8</td> <td style="text-align: center;">4071.0</td> <td style="text-align: center;">KΩ</td> </tr> <tr> <td>V-I Slope Average</td> <td style="text-align: center;">24620.2</td> <td style="text-align: center;">15238.2</td> <td style="text-align: center;">KΩ</td> </tr> </tbody> </table> <p>NOTE: Failures indicated in red, enclosed by parenthesis</p>				Part a.	Mode A	Mode B	Units	V-I Slope Minimum	6457.8	4071.0	KΩ	V-I Slope Average	24620.2	15238.2	KΩ
Part a.	Mode A	Mode B	Units												
V-I Slope Minimum	6457.8	4071.0	KΩ												
V-I Slope Average	24620.2	15238.2	KΩ												

Test # and Label		Part(s)	Result(s)		
33.1.5 – PD Classification Signature		a	PASS		
Expected Results and Procedural Comments					
<p>Using Testing Configuration A, verify that the DUT provides proper classification signature current draw.</p> <p>a. The current drawn by the DUT should fall within the range (inclusive) specified for each supported class.</p>					
Comments on Test Results					
Part a.		Mode A	Mode B	Units	
Class 0	Avg. Signature Current	Not Applicable	Not Applicable	mA	
Class 1	Avg. Signature Current	Not Applicable	Not Applicable	mA	
Class 2	Avg. Signature Current	18.064	18.069	mA	
Class 3	Avg. Signature Current	Not Applicable	Not Applicable	mA	
Class 4	Avg. Signature Current	Not Applicable	Not Applicable	mA	
NOTE: Failures indicated in red, enclosed by parenthesis					

Test # and Label		Part(s)	Result(s)		
33.1.6 – Input Average Power		a	PASS		
Expected Results and Procedural Comments					
<p>Using Testing Configuration B, verify that the DUT provides proper information about its maximum power requirements, and that those requirements fall within the acceptable range.</p> <p>a. The power drawn by the DUT should fall within the range (inclusive) specified for each supported class.</p>					
Comments on Test Results					
Part a.		Mode A	Mode B	Units	
Class 0	Power Draw at 44 V	Not Applicable	Not Applicable	W	
	Power Draw at 57 V	Not Applicable	Not Applicable	W	
Class 1	Power Draw at 44 V	Not Applicable	Not Applicable	W	
	Power Draw at 57 V	Not Applicable	Not Applicable	W	
Class 2	Power Draw at 44 V	5.441	5.431	W	
	Power Draw at 57 V	5.396	5.383	W	
Class 3	Power Draw at 44 V	Not Applicable	Not Applicable	W	
	Power Draw at 57 V	Not Applicable	Not Applicable	W	
Class 4	Power Draw at 44 V	Not Applicable	Not Applicable	W	
	Power Draw at 57 V	Not Applicable	Not Applicable	W	
NOTE: Failures indicated in red, enclosed by parenthesis					

Test # and Label	Part(s)	Result(s)
33.1.7 – Backfeed Voltage	a	PASS
Expected Results and Procedural Comments		
<p>Using Testing Configuration A, verify that when the DUT is powered, the voltage on the opposite mode, across a 100kΩ resistor is less than V_{bid}, or 2.8V.</p> <p>a. The voltage across the 100kΩ should be less than 2.8V</p>		
Comments on Test Results		
<p>a. The voltage across the 100kΩ resistor was observed to be 0V.</p>		

Test # and Label	Part(s)	Result(s)
33.1.8 – PD Power Supply Turn On / Off	a	PASS
	b	PASS
	c	PASS
Expected Results and Procedural Comments		
<p>Using Testing Configuration A, verify that the DUT will turn on its power supply once power has been applied to the PI, will remain on over the entire port voltage range, and turn off its power supply once power is removed.</p> <p>a. The DUT should turn on its power supply at a port voltage less than 42 V. b. Once turned on, the DUTs power supply should remain on for port voltages over the range of 44 V to 57V. c. The DUT should turn off its power supply at a port voltage greater than 30V and less than 36 V.</p>		
Comments on Test Results		
<p>a. Mode A - The DUTs power supply was observed to properly turn on at a port voltage less than 42 V. Mode B - The DUTs power supply was observed to properly turn on at a port voltage less than 42 V. b. The DUT remained operational throughout the entire range of port voltages. c. Mode A - The DUTs power supply was observed to turn off at a port voltage of 33 V. Mode B - The DUTs power supply was observed to turn off at a port voltage of 33 V.</p>		

Annex A: Figures

Attached are plots of the data taken for signature resistance and classification current draws. These data points were obtained using digital multimeter and a digital power supply. The data was downloaded and post processed using custom Matlab scripts.



Figure 1: Mode A Detection Signature Characteristics
V-I Curve

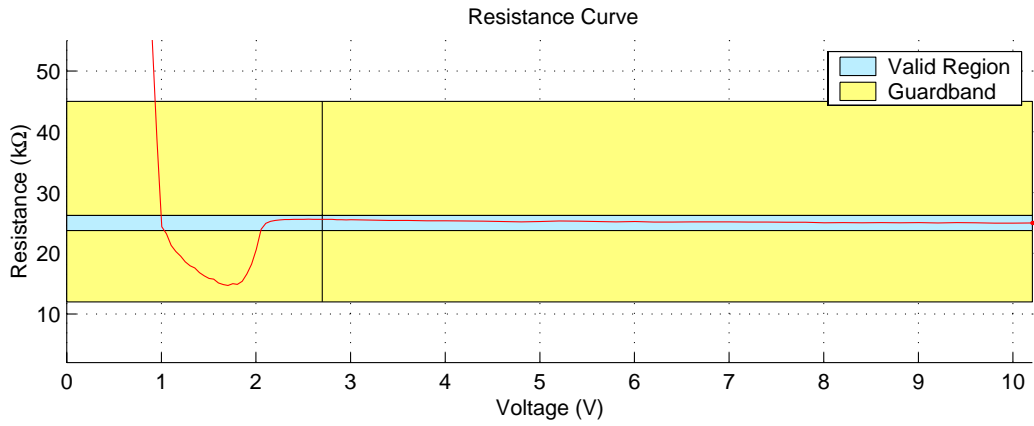
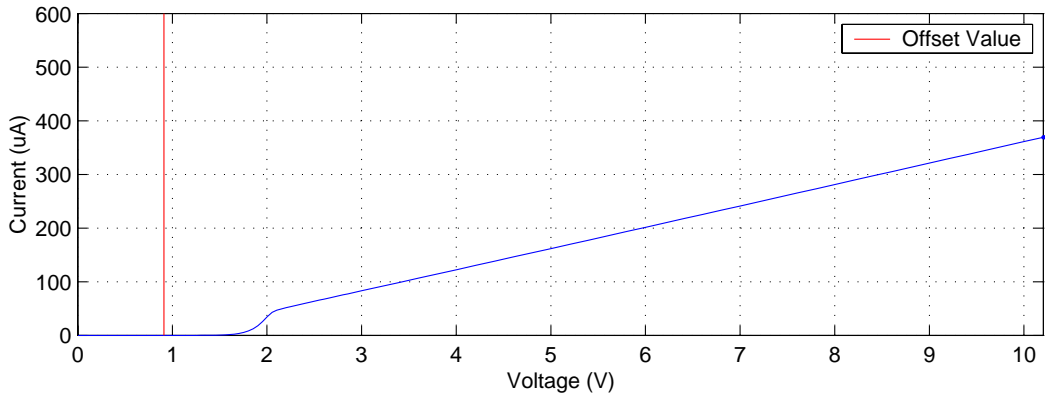

Figure 2: Mode B Detection Signature Characteristics
V-I Curve

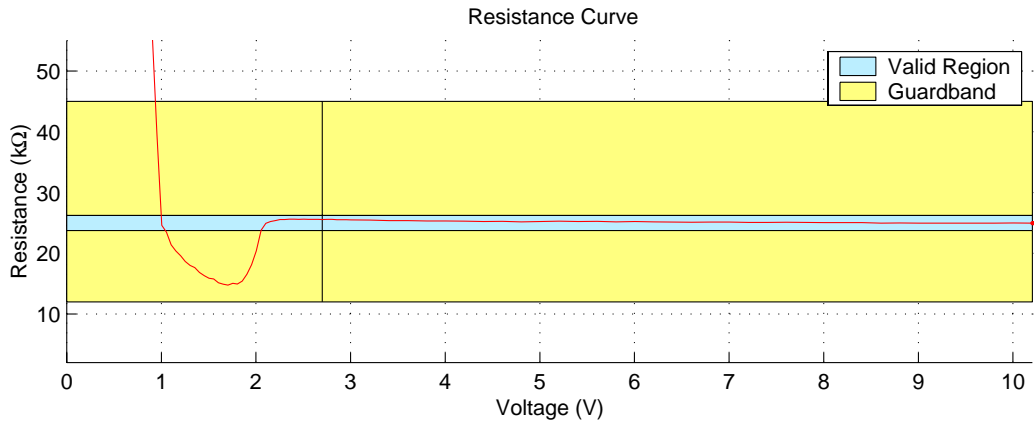
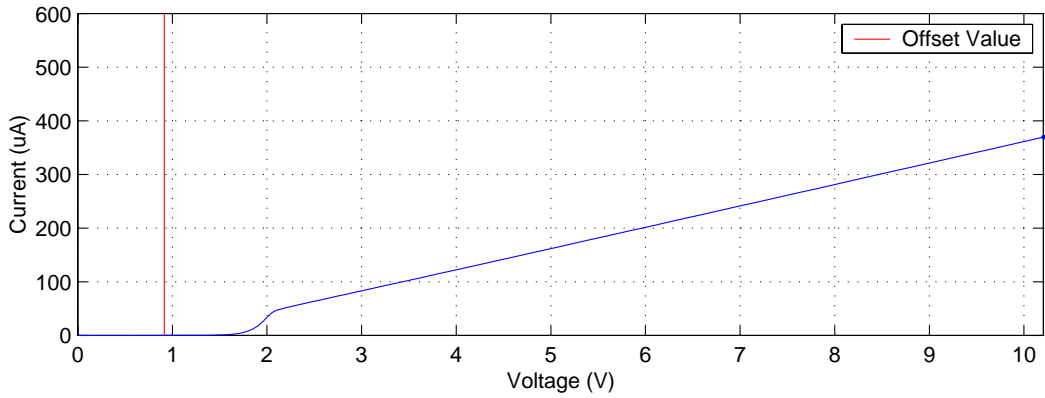

Figure 3: Mode A Classification Signature Characteristics – Class 2

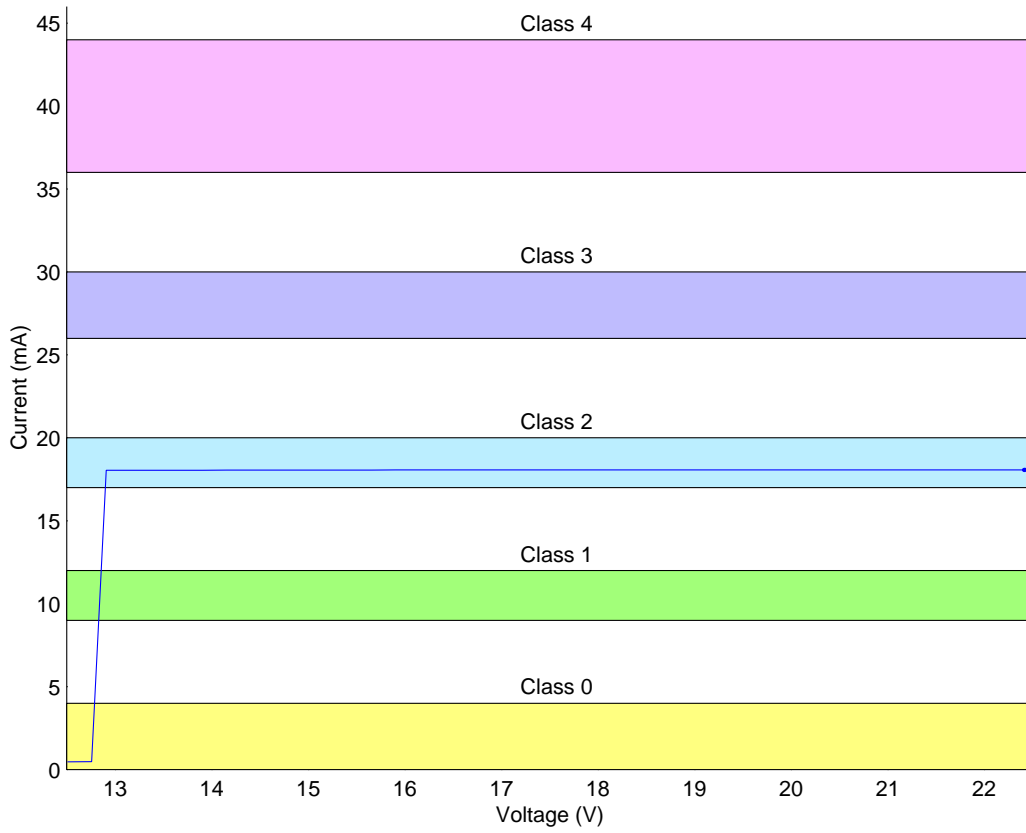

Figure 4: Mode B Classification Signature Characteristics – Class 2

