

Tiny Temperature Sensors for Portable Systems

Tiny Packages

Thermistors versus ICs

Tiny Package Temperature Sensor Summary

- 4-bump micro SMD: **LM20***
- 5-bump micro SMD: **LM74***
- 8-pin LLP: **LM70***
- 5-lead SC70: **LM20***
- 3-lead SOT-23: LM45, LM50,
LM60, LM61, LM62
- 8-lead MSOP: LM75, **LM70***

** Recently Released*



Analog Applications 32

The LM20, LM45, LM50, LM60, LM61, and LM62 are analog output temperature sensors. They have various output voltage slopes (6.25mV/°C to 17mV/°C) and power supply voltage ranges (2.4V to 10V). The LM20 is the smallest, lowest power consumption analog output temperature sensor National Semiconductor has released. The LM70 and LM74 are MICROWIRE/SPI compatible digital temperature sensors. The LM70 has a resolution of 0.125°C while the LM74 has a resolution of 0.625°C. The LM74 is the most accurate of the two with an accuracy better than $\pm 1.25^\circ\text{C}$. The LM75 is National's first digital output temperature sensor, released several years ago.

Thermistors versus ICs: Where ICs Win

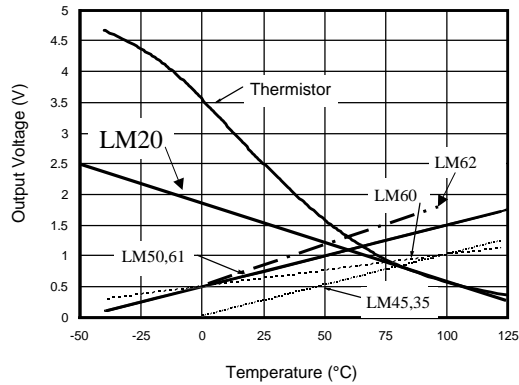

- ICs have outputs linearly proportional to temperature
- Thermistors require a look-up table or additional circuitry
- Thermistors have batch to batch dependency
- IC's have lower output impedance while maintaining LOW POWER DISSIPATION
- IC's (LM20) have comparable cost
- IC's are easier to design with

These curves compare the temperature-to-voltage transfer functions of silicon temperature sensors with that of an NTC thermistor. Thermistor non-linearities can be corrected to some extent with lookup tables, but the inherent linearity of silicon sensors greatly simplifies system design.

Thermistors versus ICs: Where Thermistors Win

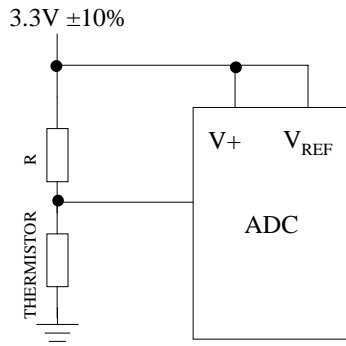

- Packaging Variety
 - Thermistors come in a wider variety of leaded packages
 - But when it comes to surface mount, ICs are equivalent
 - For case or heat sink mounting look at TO-220 packaging (LM35)
- Ratiometric operation
 - Thermistors are more accurate because they do not require an accurate ADC voltage reference
 - But if the ASIC's ADC voltage reference is not available, ICs like the LM20 are more accurate.

Thermistors come in a variety of packages ranging from probes to beads, beating ICs in that category. However ICs have surface mount packaging equivalent to thermistors, if not smaller as in the LM20 micro SMD.

Thermistors, when biased ratiometrically, have the advantage of not requiring an accurate or stable voltage reference in the system. In ratiometric operation, the error introduced by the reference is cancelled out. If ratiometric operation is not possible, for instance when the ADC reference voltage is in an ASIC and is not pinned out, using ICs like the LM20 will result in better total system accuracy.

Specific Analysis Using a Murata NTH5G10P/16P33B103F

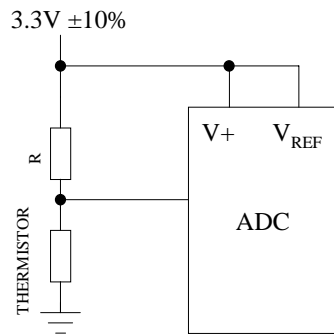

- Accuracy of the Murata thermistor - 1% at 25°C
- Overall accuracy depends on:
 - resolution of ADC
 - errors of ADC (gain, offset and linearity, sometimes combined and called Total Unadjusted Error or TUE)
 - resolution of the compensation table
- Signal level falls off logarithmically
- Power dissipation dependent upon R

We analyzed a specific thermistor, the Murata NTH5G10P/16P33B103F. This thermistor has an accuracy of 1% at 25°C. The evaluation used ADCs with various resolutions to examine the effects of quantization error on temperature accuracy.

Some thermistors have been known to have a batch dependency.

Accuracy Spec Found on the Murata Thermistor Data Sheet

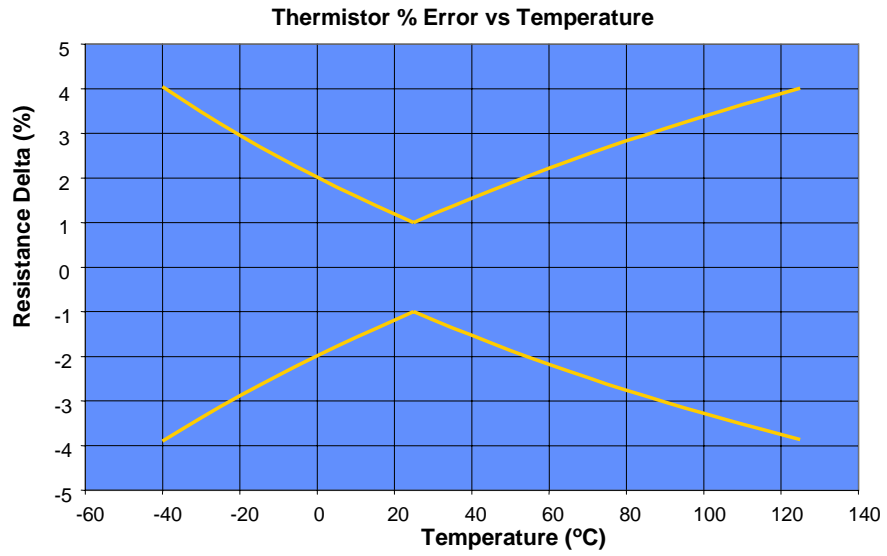

This is a plot of thermistor resistance accuracy versus temperature.

Thermistor Circuit Transfer Function with R=97.6k

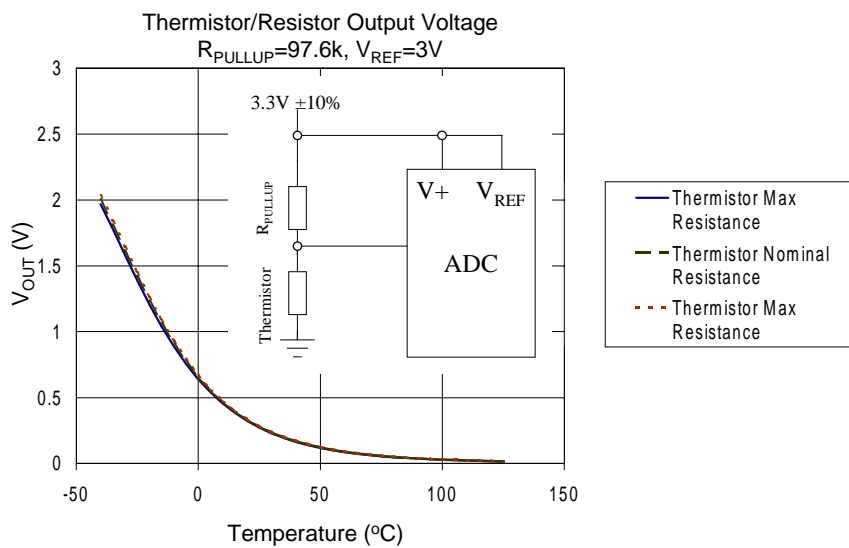

Here's a plot of the voltage generated by the resistor/thermistor divider and applied to the ADC input. Note that the ADC input voltage decreases logarithmically with increasing temperature. The 97.6k resistor minimizes the power dissipation in the thermistor, keeping the thermistor from exceeding its maximum power rating and thus maintaining the thermistor's specified accuracy.

Thermistor Circuit Transfer Function with R=4.7k

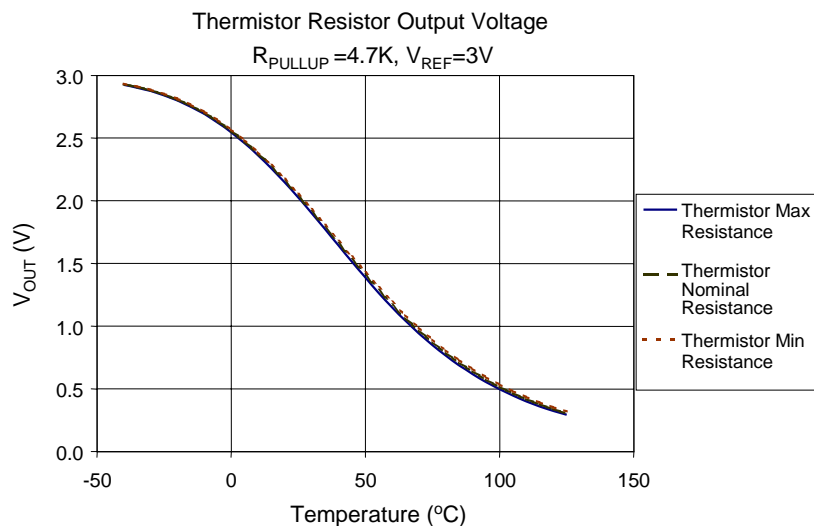

Lowering the value of the resistor from the previous slide will lower the temperature range over which the thermistor's transfer function is linear. With a 4.7k bias resistor, the slope increases at higher temperatures, providing more resolution. However this improvement comes with a price: greater power consumption in the overall circuit, and self-heating in the thermistor itself, causing elevated temperature readings (in this case about 0.2-0.3 $^{\circ}C$).

Thermistor Accuracy Including ADC Errors

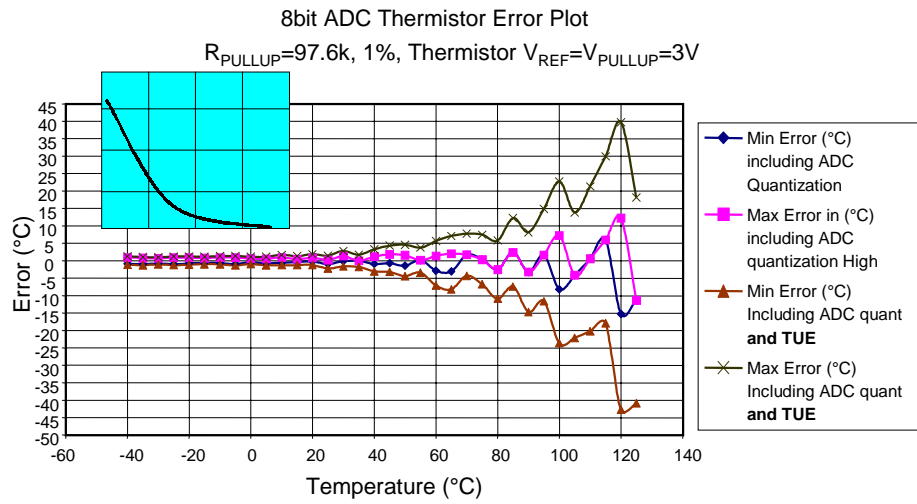

30μA thermistor bias current



This plot shows the overall system accuracy when using an 8-bit ADC. In a real world application, the quantization error and ADC Total Unadjusted Error must be considered to determine the overall system error. Note how quickly the temperature error due to the ADC's TUE and quantization error start to increase above room temperature.

Specific Analysis Using an LM20

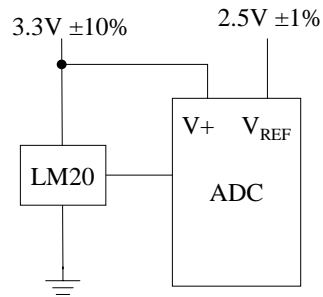

- $\pm 1.5^{\circ}\text{C}$ accuracy at 30°C
- Signal slope constant over total temperature range $\sim -11\text{mV}/^{\circ}\text{C}$
- Not ratiometric operation, so reference tolerance causes additional gain error
- $10\mu\text{A}$ max. supply current

Now let's compare an LM20 system using the same 8-bit ADC and a reference voltage with 1% accuracy. Since this is not ratiometric operation, the reference adds additional system error.

LM20 vs Thermistor (10-bit ADC)

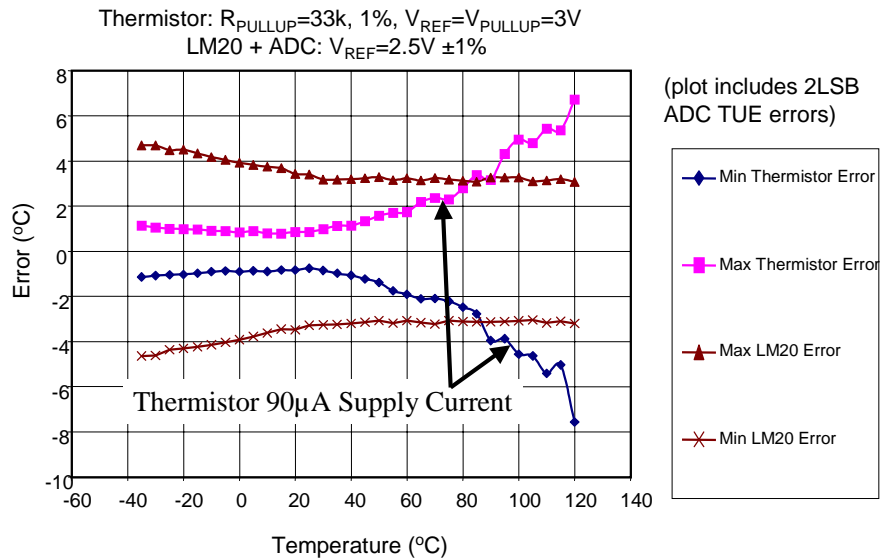

As the ADC resolution is increased, the overall system error decreases because the ADC's quantization error decreases. The thermistor benefits the most because it is running ratiometrically while the LM20 is not, so the reference voltage error dominates over the improved accuracy of the ADC. Improving the accuracy of the voltage reference will bring the LM20 system accuracy closer to that of the specifications found on the LM20 data sheet of $\pm 2.5^\circ\text{C}$ at $+130^\circ\text{C}$ and -55°C , and $\pm 1.5^\circ\text{C}$ at $+30^\circ\text{C}$. Since the output slope of the LM20 is negative the gain error introduced by the reference voltage plays less of a role in the overall accuracy as the temperature increases.

LM20 vs Thermistor (10-bit ADC)

When Supply Current Matters

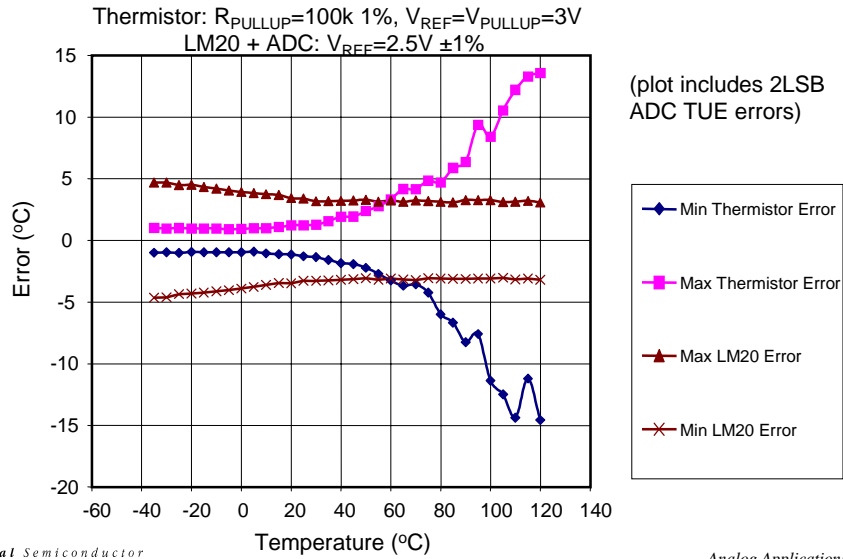

But if you want to reduce the power consumption of your thermistor source to $30\mu A$ (still 3x higher than the LM20), the thermistor performance becomes worse at about $+60^{\circ}C$.

LM74 (Digital Temp Sensor) vs Thermistor with 10-bit ADC

When Supply Current Doesn't Matter

$V_{PULLUP}=V_{REF}=2.25V$, $R_{PULLUP}=4.7k$

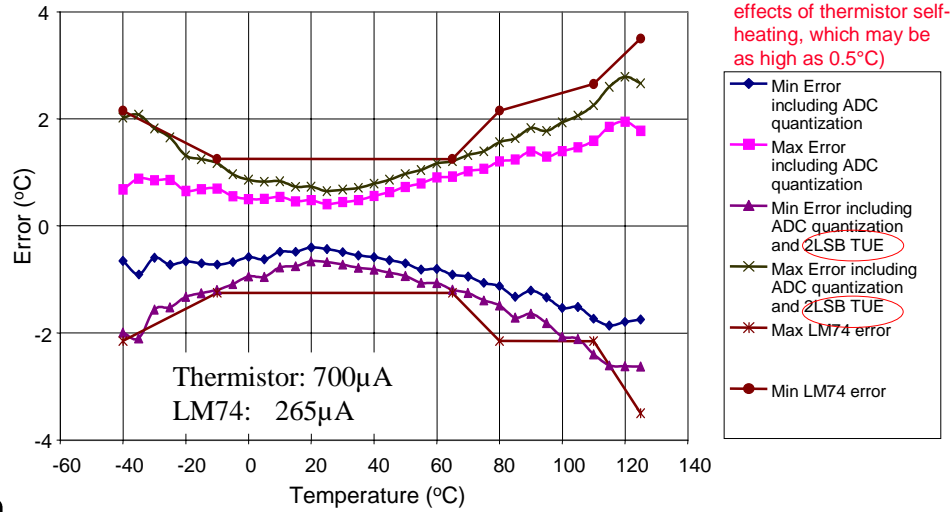

Here is a curve of the LM74 when compared to a thermistor and a 10-bit ADC. Here the pullup resistor has been lowered to 4.7k thus increasing thermistor accuracy at the cost of power dissipation. At first it may appear that the thermistor provides better performance than the LM74 but the thermistor error plots do not include the self heating error of the thermistor which can be as high as 0.5°C.

The LM74 comes in two flavors, the LM74-3, optimized for 3V power supplies, and the LM74-5, optimized for 5V.

LM74 vs Thermistor with 10-bit ADC

When using an ASIC watch out for the ADC TUE!

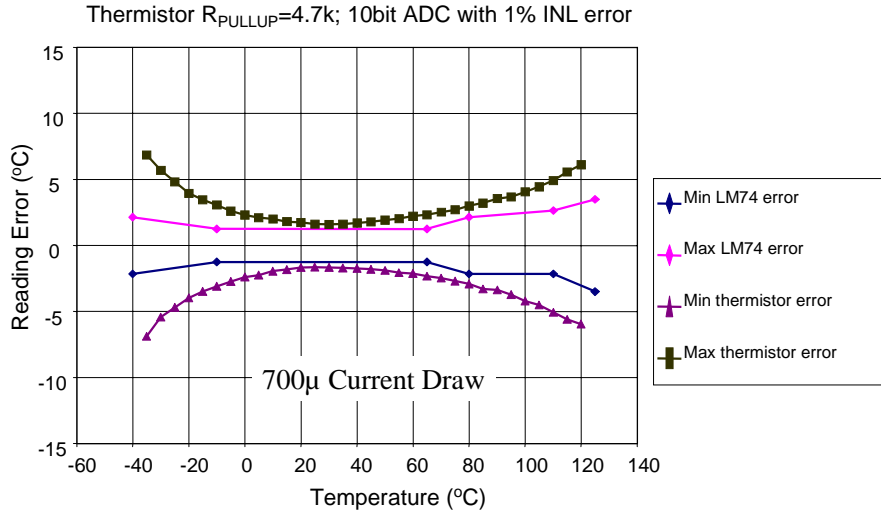

This plot shows how the performance of the thermistor is degraded when using an ASIC that has a 10-bit ADC with an overall DC accuracy of 1%. This is the case with many ASICs that have an imbedded ADC intended for use in digitizing high speed AC signals. They usually have excellent AC performance specifications (THD, SNR, ...), but lackluster DC performance (TUE, GAIN, OFFSET, INL). DC performance is what matters when digitizing a thermistor. Don't be fooled by the resolution of the ADC - check out its DC performance.

LM20 Driving ADC Inputs

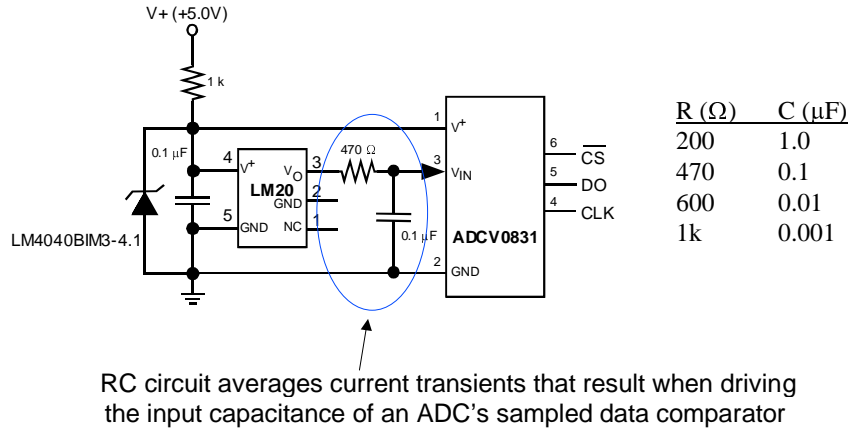

The LM20 has a $10\mu\text{A}$ maximum supply current rating. In order to minimize the supply current, the output buffer in the LM20 has a very low bandwidth. When driving ADCs with sampled data comparator inputs, such as the ADCV0831 and those found on most CMOS ASICs, there is a requirement that the signal source provide a large peak current at the time of sampling. The LM20 output cannot provide this current and settle its output voltage in the time before the ADC acquisition window ends. The solution is the addition of a $0.1\mu\text{F}$ reservoir capacitor to store charge and provide the necessary current required at the time the ADC samples the analog input. This eases the requirements on the LM20's output stage. The LM20 needs only to charge the capacitor back up to the proper voltage before another sample is taken. If the ADC samples again before the capacitor is recharged, an error voltage will be induced. The value of the capacitor should be empirically derived since the capacitance of the ADC's input stage at time of sampling varies greatly from one ADC manufacturer to another.

When Should You Use IC Temperature Sensors?

- When the sensor's temperature range will be between -55°C and $+150^{\circ}\text{C}$
 - Electronic Systems Monitoring
 - Environmental Controls and Measurements
- When system cost is important
- When design time must be minimized
- When space is at a premium
- When low supply current is a requirement

Designers have numerous options for temperature sensing techniques. Thermistors, RTDs, thermocouples, and active silicon sensors are among the most common, and each has its own set of advantages and disadvantages in any application. IC sensors have major advantages when the temperatures to be measured fall within the normal operating temperature range of silicon ICs. Among these advantages are low system cost, small size, and fast design time (because external signal conditioning circuitry is either minimal or not required). In addition, sensor ICs can include extensive additional functions, such as built-in comparator trip-points or digital I/O. And, since they include on-chip linearity correction when needed, there is no need for lookup tables to correct linearity errors.