

# PLL Fundamentals

## Part 3: PLL Design

**Dean Banerjee**

# Overview

- Frequency Planning
  - **Number Theory Overview**
  - Types of Frequency Plans
- Loop Filter Design
  - Choosing Loop Parameters
  - Tricks and Tips for Optimization
- Practical Things that Textbooks Won't Tell You
  - Real World Component Values
  - Suggestions for Various Pins
  - PLL Debugging Tips

# Less Known Divisibility Rules

- **Divisibility by 2,4, & 8**

- Even numbers are divisible by 2
- Divisible by 4 if the last 2 digits are divisible by 4
- Divisible by 8 if the last 3 digits are divisible by 8

- **Divisibility by 3 & 9**

- A number is divisible by 3 if the sum of the digits is divisible by 3
- A number is divisible by 9 if the sum of the digits is divisible by 9
- 367218 is divisible by 9 since  $3+6+7+2+1+8$  is divisible by 9

- **Divisibility by 11**

- A number is divisible by 11 if the sum of odd and even digits is divisible by 11
- 12111 is divisible by 11 since  $1-2+1-1+1$  is divisible by 11

# Least Common Multiple (LCM)

- This is the least number that is a multiple of a collection of two or more numbers
  - $\text{LCM}(6,14) = 42$
  - $\text{LCM}(A,B,C) = \text{LCM}(\text{LCM}(A,B), C)$
- This can be expanded to rational numbers
  - $\text{LCM}(30.72 \text{ MHz}, 61.44 \text{ MHz}) = 61.44 \text{ MHz}$
- A general technique for any fraction such as  $\text{LCM}(5/3, 17/12)$ 
  - $5/3 \times A = \text{LCM}(5/3, 17/12)$
  - $17/12 \times B = \text{LCM}(5/3, 17/12)$
  - $B/A = (5/3)/(17/12) = 60/17 = 20/17 \Rightarrow B = 20$
  - $\text{LCM}(5/3, 17/12) = 17/12 \times 20 = 85/3$

# Greatest Common Divisor (GCD)

- This is the greatest number that divides into two or more numbers
  - $\text{GCD}(6,14) = 2$
  - $\text{GCD}(A,B,C) = \text{GCD}(\text{GCD}(A,B), C)$
- This can be expanded to rational numbers
  - $\text{LCM}(10 \text{ MHz}, 21 \text{ MHz}) = 1 \text{ MHz}$
- A general technique for any fraction such as  $\text{GCD}(5/3, 17/12)$ 
  - $\text{GCD}(5/3, 17/12) \times A = 5/3$
  - $\text{GCD}(5/3, 17/12) \times B = 17/12$
  - $A/B = (5/3)/(17/12) = 60/51 = 20/17 \Rightarrow A = 20$
  - $\text{GCD}(5/3, 17/12) = (5/3)/20 = 1/12$

# Alternative Calculation Method

- Works for Non-Repeating Decimals
- Calculate LCM and GCD of 14.4 and 16.44
- **LCM = 15 x 64 x 3 x 2 x 4 x 4 x 0.01 = 921.6**
  - 15 x 14.4 = 921.6
  - 64 x 16.44 = 921.6
- **GCD = 0.01 x 4 x 4 x 2 x 3 = 0.96**
  - 14.4/15 = 0.96
  - 16.44/64 = 0.96

|      | 14.4 | 61.44 |
|------|------|-------|
| 0.01 | 1440 | 6144  |
| 4    | 360  | 1536  |
| 4    | 90   | 384   |
| 2    | 45   | 192   |
| 3    | 15   | 64    |

# Overview

- Frequency Planning
  - Number Theory Overview
  - **Types of Frequency Plans**
- Loop Filter Design
  - Choosing Loop Parameters
  - Tricks and Tips for Optimization
- Practical Things that Textbooks Won't Tell You
  - Real World Component Values
  - Suggestions for Various Pins
  - PLL Debugging Tips

# Types of Frequency Plans

|                         | <b>Fixed Frequencies</b>    | <b>Variable Frequencies</b> |
|-------------------------|-----------------------------|-----------------------------|
| <b>Single Output</b>    | Fixed Frequency Plan        | Tunable Frequency Plan      |
| <b>Multiple Outputs</b> | Simultaneous Frequency Plan | Not too Common              |



# Traditional Tunable Frequency Method

- Phase Detector Frequency is fixed and the N divider changes
- Try to Optimize the Phase Detector frequency
  - Integer N PLL: Equal to the spacing,  $\text{GCD}(f_1, \dots, f_k)$
  - Fractional N PLL: Can be made typically as large as  $f_{\text{osc}}$  ( i.e.  $F_{\text{den}} \times \text{GCD}(f_1 \dots f_k)$  )

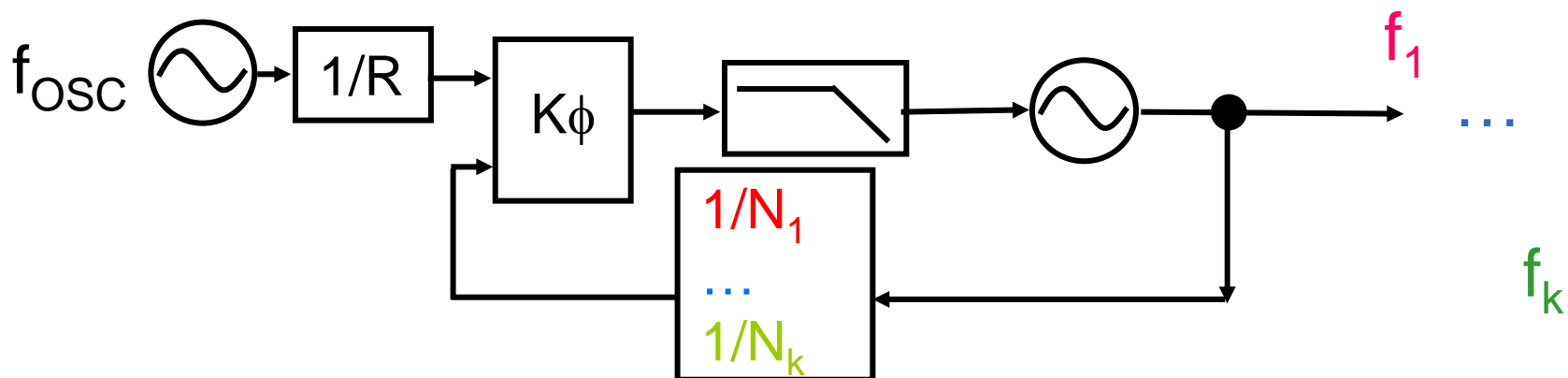

# Other Tunable Frequency Method

- Each frequency can have its own phase detector frequency, VCO frequency, and channel divide value
- Filter Optimization Tips ...
  - Maximize phase detector frequency
    - Reduce fraction  $N/R$  to lowest terms
    - Equivalent to making  $f_{PD} = \text{GCD}(f_{VCO1}, f_{VCO2}, f_{VCO3}, f_{OSC})$
  - Minimize variation of 
$$\frac{K\phi \cdot K_{vco}}{N}$$
  - Use Lower order Filters

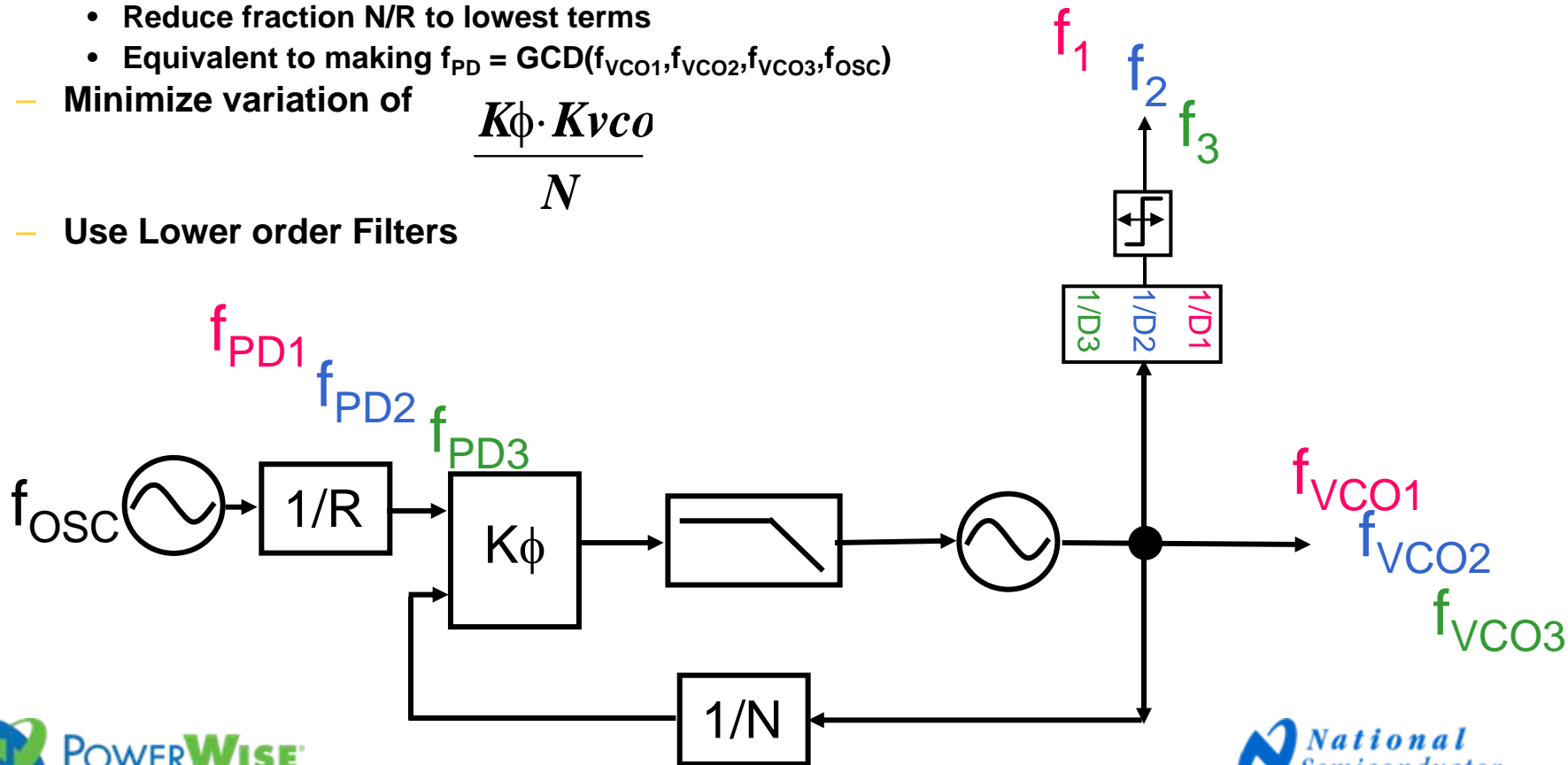

# Simultaneous Frequency Planning Techniques

- $f_{VCO} = k \times \text{LCM}(f_1, f_2, f_3)$ 
  - $k = 1, 2, 3, \dots$
  - VCO Frequency may require that  $k > 1$
- $f_{PD} = \text{GCD}(f_{VCO}, f_{OSC}) / c$ 
  - $c = 1, 2, 3, \dots$ , where 1 is preferable
  - N counter and VCO Divider may require  $c > 1$
  - Fractional N can lower this value for  $c$

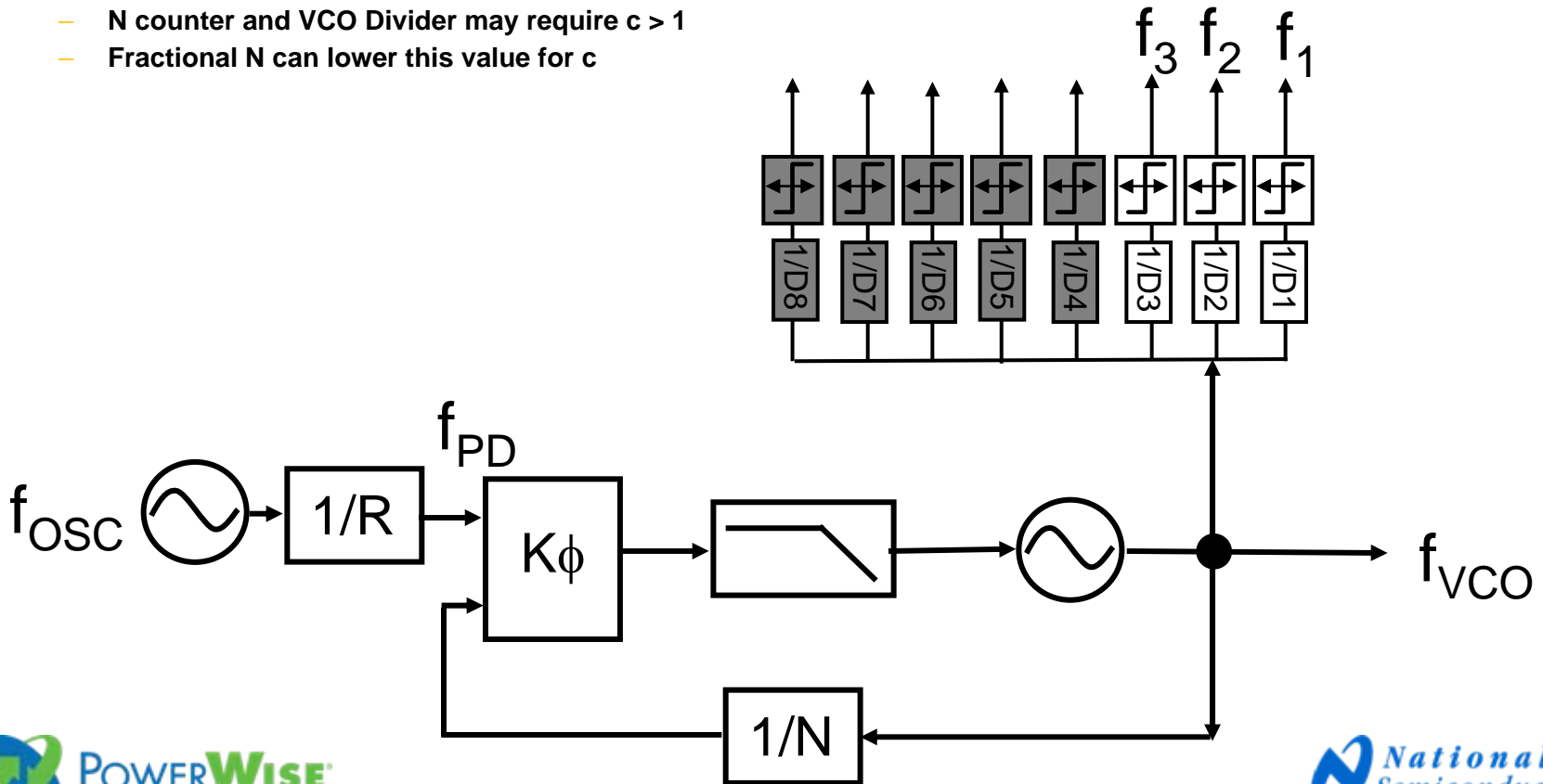

# Overview

- Frequency Planning
  - Number Theory Overview
  - Types of Frequency Plans
- Loop Filter Design
  - Choosing Loop Parameters
  - Tricks and Tips for Optimization
- Practical Things that Textbooks Won't Tell You
  - Real World Component Values
  - Suggestions for Various Pins
  - PLL Debugging Tips

# Loop Filter Design

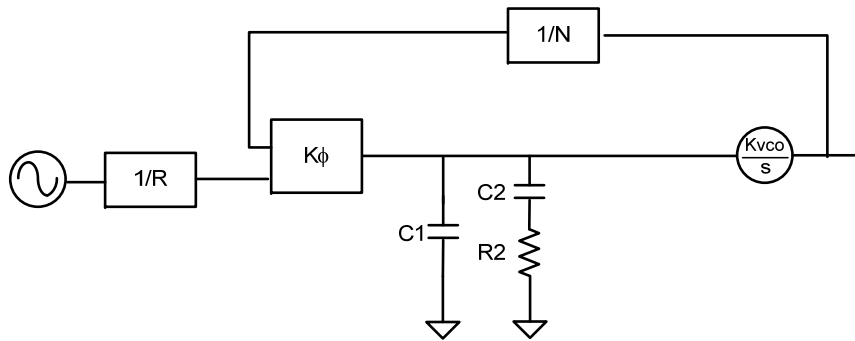

$$Z(s) = \frac{1 + C2 \cdot R2}{(C1 + C2) \cdot \left(1 + s \cdot \frac{C1 \cdot C2}{C1 + C2}\right)} = \frac{1 + T2}{(C1 + C2) \cdot (1 + s \cdot T1)}$$

- **Need to solve for 3 Unknowns**

- T1
- T2
- C1+C2

# Loop Bandwidth, Phase Margin, Gamma

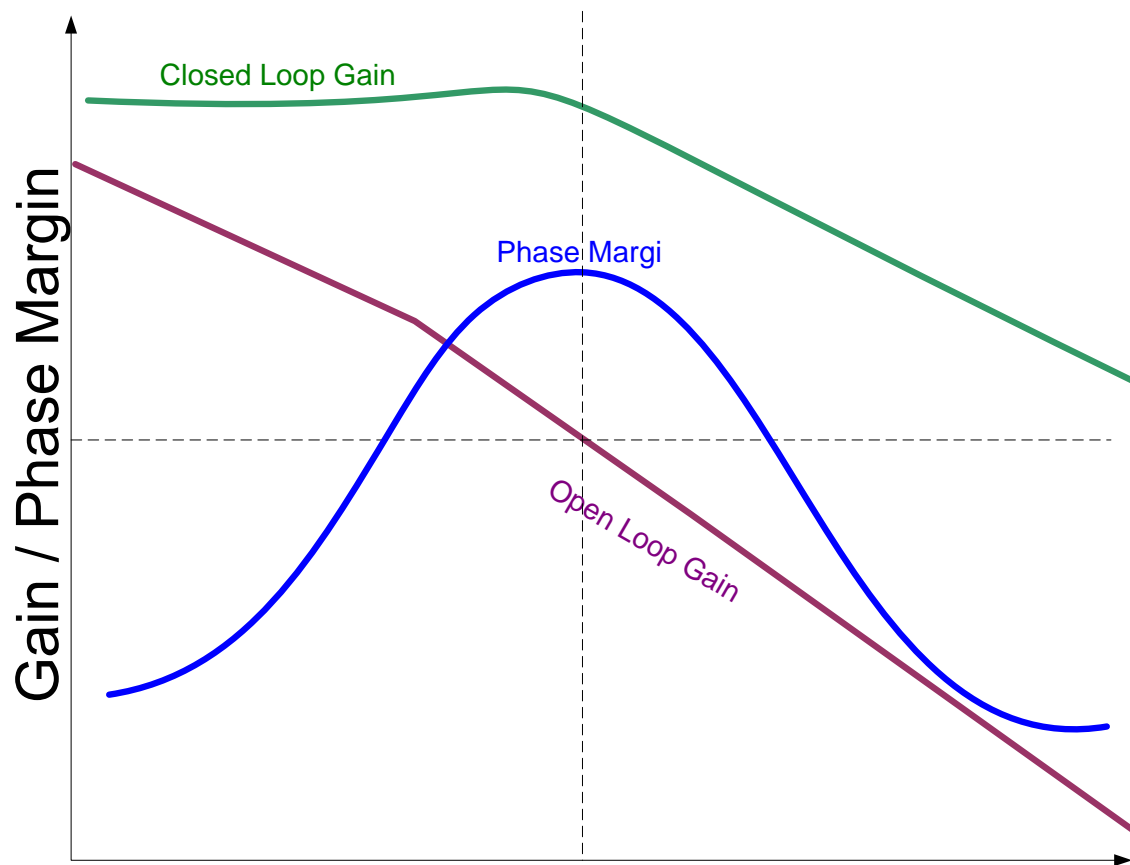

# How Do I Pick Loop Bandwidth?

- **Loop Bandwidth  $\leq f_{PD} / 10$** 
  - Violating this causes instability issues due to discrete sampling action of the phase detector
- **Wider Loop Bandwidth > Faster Lock Time, but Worse Spurs**
- **Choosing the loop bandwidth equal to the frequency where PLL noise and VCO noise are equal optimize the integrated phase noise (i.e. jitter, phase error, evm, ...)**
  - Actually, make about 25% wider to account for fact that loop filter is not a brick wall filter
  - This does not account for spurs

# Minimum Integrated Phase Noise Bandwidth

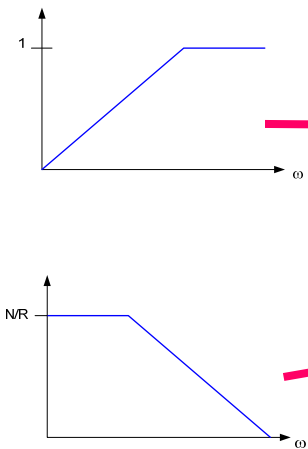

Crossover = 50 kHz  
Make BW = 50 kHz \* 1.2

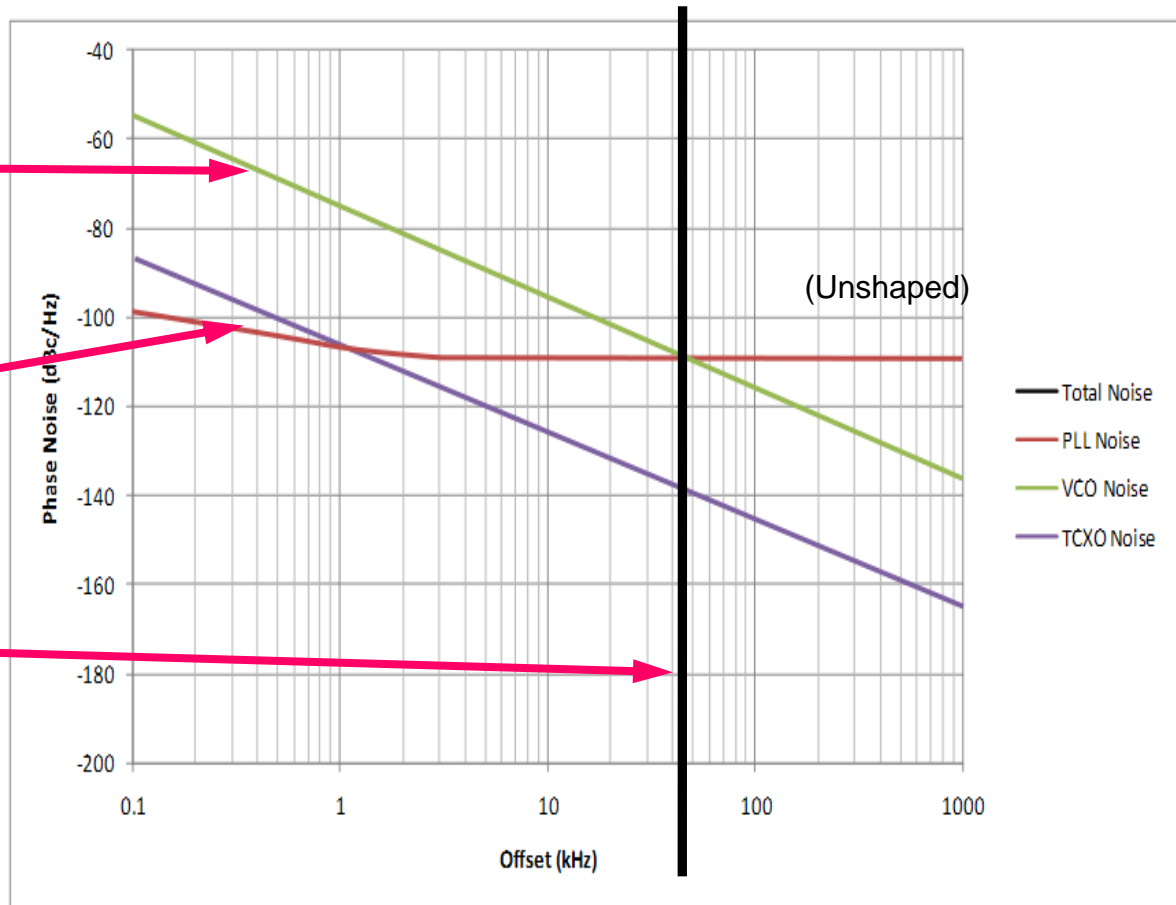

# How Do I Pick Phase Margin?

- **70 – 80 degrees is for a very flat response and for minimum integrated phase noise**
- **48 degrees (varies a little from design to design) is optimal for lock time**
- **Lower Phase Margin is good for slightly better spurs, especially for higher order filters**

# How do I Pick Gamma?

- **Given a phase margin, Gamma can be estimated for optimal lock time, and typically this is best for spurs too.**
- **For some pathological cases involving partially integrated loop filters, gamma can be tweaked for a wider loop bandwidth**

| Phase Margin | $\gamma$ for Fastest Lock Time |
|--------------|--------------------------------|
| 30           | 1.4                            |
| 35           | 1.41                           |
| 40           | 1.29                           |
| 45           | 1.09                           |
| 50           | 0.94                           |
| 55           | 0.85                           |
| 60           | 0.7                            |
| 65           | 0.49                           |
| 70           | 0.24                           |
| 75           | 0.05                           |
| 80           | 0.08                           |

# Apply the Constraints

- **Apply Constraint that forward loop gain at loop bandwidth frequency is equal to 1**

$$\left\| \frac{K_{PD} \cdot K_{VCO}}{N \cdot s} \cdot \frac{1 + T2}{s \cdot (C1 + C2) \cdot (1 + s \cdot T1)} \right\|_{s=2\pi \cdot BW} = 1$$

- **Set Phase Margin to Desired Value,  $\phi$**

$$\phi = 180 + \tan^{-1}(2\pi \cdot BW \cdot T2) - \tan^{-1}(2\pi \cdot BW \cdot T1)$$

- **Apply Constraint that phase margin is maximized at loop bandwidth and define parameter,  $\gamma$**

$$\gamma = \frac{1}{(2\pi \cdot BW)^2 \cdot T2 \cdot T1}$$

# What About Higher Order Filters?

- **3<sup>rd</sup> Order Filter**
  - Define T3/T1 Ratio as an additional constraint
  - Maximize value of C3 (closest to VCO)
- **4<sup>th</sup> Order Filter**
  - Define T3/T1 Ratio
  - Define T4/T3 Ratio
  - Choose C1 and C3 to maximize C4
- **Filter with C3, C4, R3, R4 Integrated**
  - No constraints to define

# Possible Design Approach

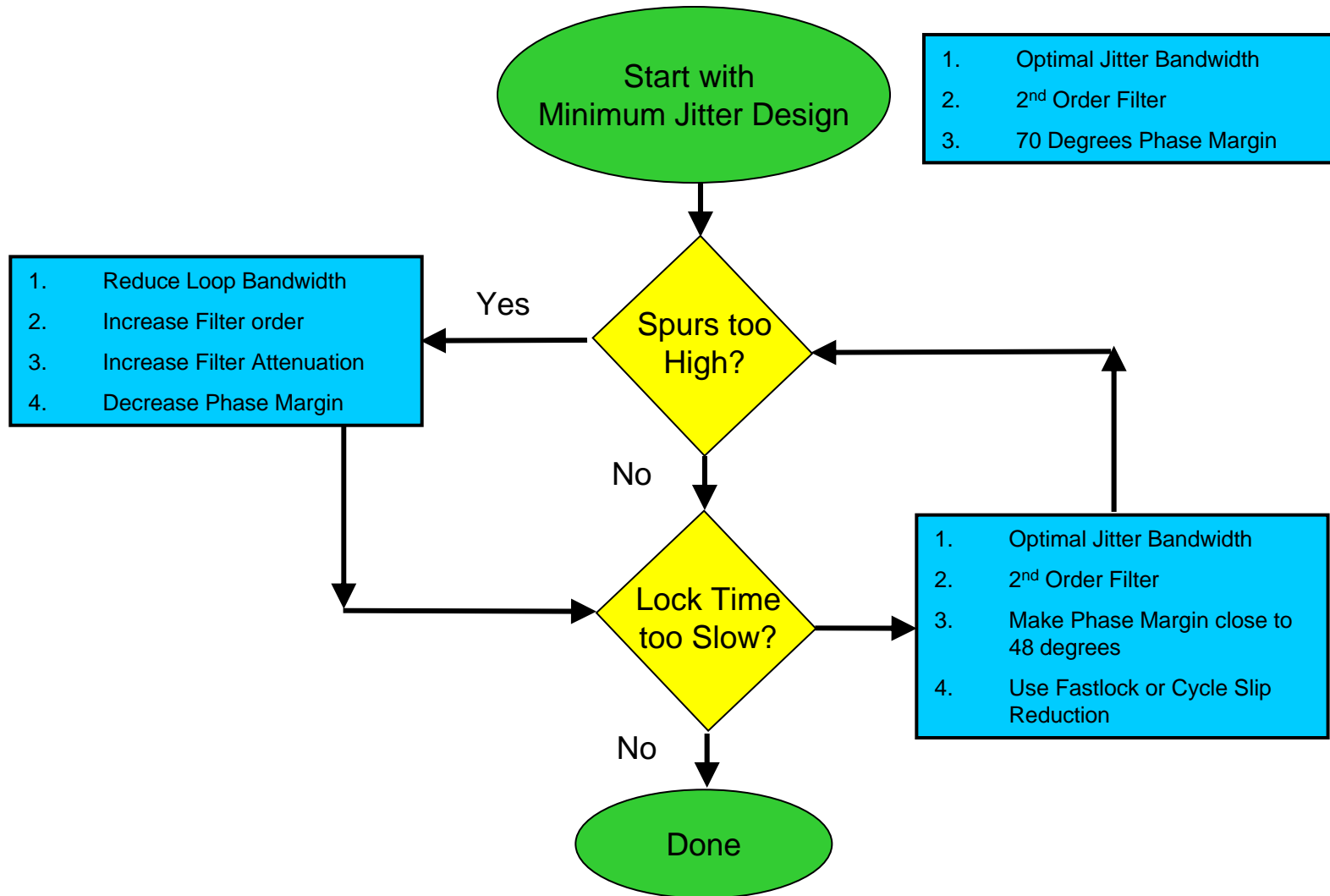

# More Common Approach

- Often times when presenting loop filter design, it gives an increased appreciation of the various design tools. National Semiconductor has excellent design and simulation tools at [www.national.com](http://www.national.com)
- For those seeking more details on the math, consult “PLL Performance, Simulation, and Design”, by Dean Banerjee

# Active Filter Example

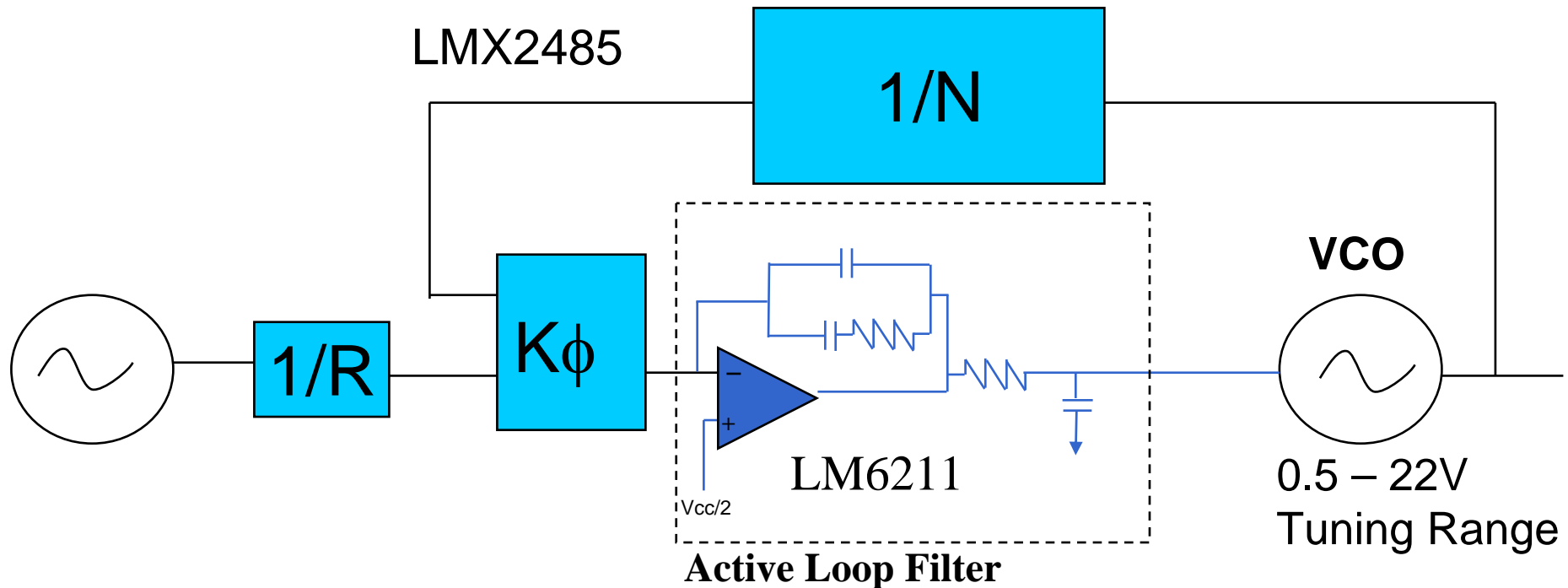

- Pole After op-amp reduces op-amp noise
- Voltage is centered at half charge pump supply for optimal spurs



# LM6211 Op-Amp

- **Allows Much Wider Tuning Voltage for VCOs**
  - 5 to 24 volt operation
  - Goes to within about 100 mV of rail
- **Minimal Added Noise**
  - Voltage Noise = 5.5 nV/Sqrt(Hz)
  - Current Noise = 0.01 pA/Sqrt(Hz)
- **Requires No Negative Supply**
  - Input can go to 0 volts.
- **Does not Cause Large Spurs**
  - Input Bias Current = 10 nA max
- **Small Package**
  - SOT23-5
- **Low Current**
  - 1 mA

# Summary – Rules of Thumb

| PLL Functional Block                  | To minimize Noise contribution...   | Why?  |
|---------------------------------------|---|---|
| Phase Detector/Charge Pump            | Maximize charge pump gain ( $K_{\phi}$ ) (up to a certain point)  | The phase detector noise contribution is theoretically proportional to $1/(K_{\phi})^2$ |
| R-counter and N-counter divide ratios | Maximize phase detector comparison frequency $\rightarrow$ this minimizes N   | The noise contribution of the R and N dividers is proportional to $N^2$ .               |
| Reference oscillator                  | Use highest frequency practical and use $R > 1$ if possible. If deciding between maximizing R and minimizing N, minimize N. | The noise contribution from the reference oscillator is proportional to $(N/R)^2$       |

# Overview

- Frequency Planning
  - Number Theory Overview
  - Types of Frequency Plans
- Loop Filter Design
  - Choosing Loop Parameters
  - Tricks and Tips for Optimization
- Practical Things that Textbooks Won't Tell You
  - **Real World Component Values**
  - Suggestions for Various Pins
  - PLL Debugging Tips

# Real World Resistor

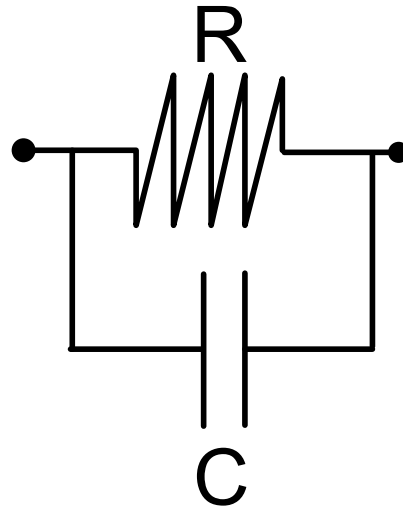

- For high resistance values and high frequencies, resistor might not look like its theoretical value
- $C \sim 0.2 \text{ pF}$

# Real World Capacitor (ESR)



- **Capacitors have an equivalent series Resistance (ESR)**
  - ~ 0.05 ohms for ceramic caps
  - Bigger for larger caps
  - Several ohms for tantalum caps
  - Due to ESR, not always best to choose largest capacitor for power supply
- **Self-Resonant Frequency**
  - Above this frequency, cap looks more like an inductor with a DC block
  - Sometimes good for high frequency input of PLL
- **Dielectric Absorption**
  - If a voltage is applied across a cap, then a short, a residual voltage can appear
  - Don't see this effect as much for COG (NP0) and film capacitors
  - Can increase lock times (even up to 5X) if
    - Phase Detector frequency is lower (< 1 MHz)

# Overview

- Frequency Planning
  - Number Theory Overview
  - Types of Frequency Plans
- Loop Filter Design
  - Choosing Loop Parameters
  - Tricks and Tips for Optimization
- Practical Things that Textbooks Won't Tell You
  - Real World Component Values
  - **Suggestions for Various Pins**
  - PLL Debugging Tips

# TCXO Input Pin

- **Some Parts are sensitive to the slew rate of the signal**
  - Better Spurs for faster slew rate
  - Better phase noise for faster slew rate
- **Other parts are really not that sensitive**
- **Often times, this is high impedance at these lower frequencies, so a 51 ohm resistor to ground often does work.**

# High Frequency Input Pin from VCO

- **Input Impedance tends to be capacitive and is not always high impedance, especially at higher frequencies**
- **Smaller capacitors are good for higher frequencies, but don't get carried away.**
  - Keep the Reactance no more than about 1 ohm
  - Too low value allows harmonics to pass through easier
- **Resistive splitter or pad is most reliable**
- **Sometimes, increasing this attenuation can improve spurs if they are outside the loop bandwidth**
  - If you see that spurs get worse with higher charge pump current, even when filter is redesigned for the same loop bandwidth
  - If you see that fractional spurs of the same offset get worse with higher phase detector frequency, even when filter is redesigned for the same loop bandwidth

# Power Supply Pins

- **Integrated Regulator Output Pins**
  - Sometimes sensitive to too low ESR for devices with integrated VCO
- **Charge Pump Supplies can be sensitive**

# VCO Power Supply Noise Impact

- **Influenced by Pushing of the VCO**

$$\beta = \frac{\text{Frequency Deviation}}{\text{Modulation Frequency}} = \frac{K_{\text{PUSH}} \cdot V_{\text{IN}}(f)}{f}$$

$$\text{Sideband}(f) = 20 \cdot \log|J_1(\beta)| = 20 \cdot \log\left(\frac{\beta}{2} - \frac{\beta^3}{2^2 \cdot 4} + \frac{\beta^5}{2^2 \cdot 4^2 \cdot 6} + \dots\right)$$

$$\approx 20 \cdot \log\left(\frac{\beta}{2}\right) \quad \text{for } \beta \ll 1$$

- **Dependent on Frequency**
- **PSRR is loop filter and frequency dependent**



# LMX2541 Power Supply Noise Example

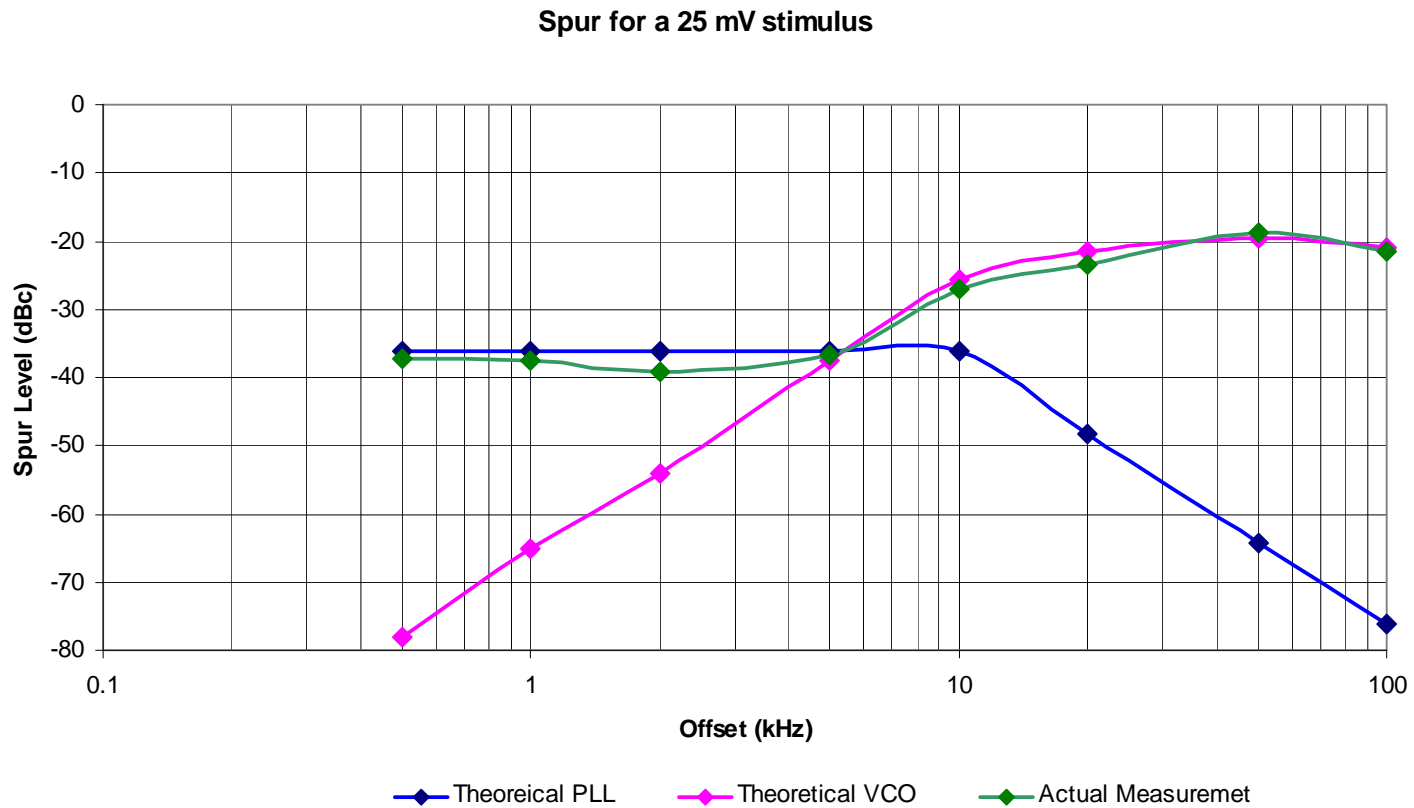



# Impact of Resistance on Vreg Pins

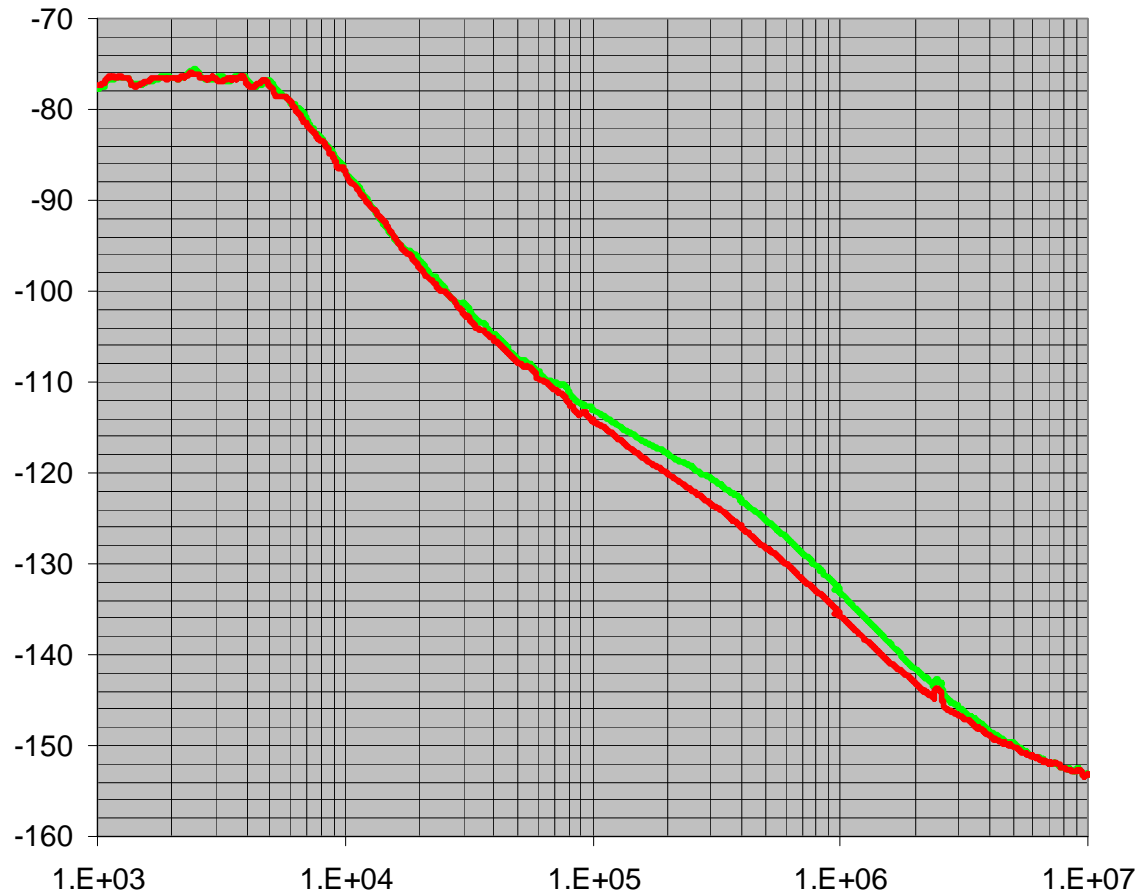

# Overview

- Frequency Planning
  - Number Theory Overview
  - Types of Frequency Plans
- Loop Filter Design
  - Choosing Loop Parameters
  - Tricks and Tips for Optimization
- Practical Things that Textbooks Won't Tell You
  - Real World Component Values
  - Suggestions for Various Pins
  - **PLL Debugging Tips**

# Quick PLL Debugging Tricks

- **Step 1: Ensure Proper Communication**
  - Typically, PLLs do not have register readback
  - Use the powerdown bit (not pin) and observe current change to ensure part is reading programming correctly
- **Step 2: Observe Proper voltages and bias levels**
  - VCO input pin typically is 1.6 V powered up, 0 V powered down
  - OSC input pin is typically  $V_{cc}/2$  powered up, 0 V powered down
  - Internal regulators can also have their bias levels
  - Be aware ESD protection diodes on parts can sort of power up unconnected pins to make the part perform with strange symptoms
- **Step 3: Check Loop Filter Issues**
  - Flip the phase detector to see the VCO jump to ensure no open/short issues
  - Lower charge pump gain and phase detector frequency to check stability issues
- **Step 4: Check the Counters**
  - Check the counter outputs at the Ftest/LD pin to ensure they are correct
  - Touching your finger to the part can sometimes help debug impedance matching issues