

# ***Design Considerations for PC Thermal Management***

***Multipoint Remote Diode Temperature Sensing (RDTS)***

***IC Topology***

***Performance in Noisy Environments***

## Why Use Multipoint Remote Diode Temperature Sensing (RDTS)?

- Most accurate method
  - Reduces or eliminates thermal gradient concerns
  - Reduces or eliminates placement issues
- Reduces component count
- Improves disk drive data integrity
  - Operating a drive at a temperature 5°C higher than recommended causes a 15% increase in failure rate
- Push the Performance Envelope
  - RDTS can lower a  $\pm 8^{\circ}\text{C}$  error to  $\pm 3^{\circ}\text{C}$ , so you can clock your system faster



Multiple RDTS (remote diode temperature sensing) provides the most accurate method of sensing an IC's junction temperature. It overcomes thermal gradient and placement issues encountered when trying to place external sensors. PCB component count decreases when using a device that provides multiple inputs.

Better temperature sensing improves product performance and reliability. Disk drive data integrity suffers at elevated temperatures. IBM published an article stating that a 5°C rise in operating temperature causes a 15% increase in the drive's failure rate. The overall performance of a system can be improved by providing a more accurate temperature measurement of the most critical devices allowing them to run just a few degrees hotter.

## Typical Application

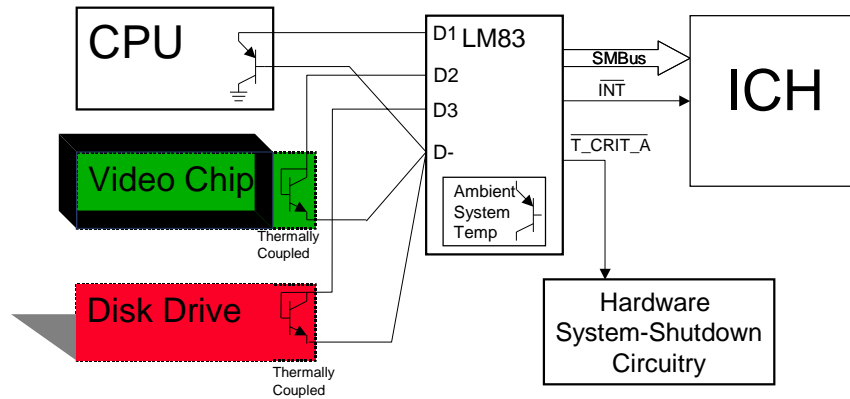

- *RDTS resolves sensor placement issues*
- *2N3904 lower \$ than Thermistor or Analog Temp Sensor*

The LM83 directly senses its own temperature and the temperature of three external PN junctions. One is dedicated to the CPU of choice, the other two go to other parts of your system that need thermal monitoring such as the disk drive or graphics chip. The SMBus-compatible LM83 supports SMBus timeout and logic levels. The LM83 has two interrupt outputs; one for user-programmable limits and WATCHDOG capability (INT), the other is a Critical Temperature Alarm output (T\_CRIT\_A) for system power supply shutdown.

# Performance w/ Noise

## Scope Photo of LM83 Diode Input Pins

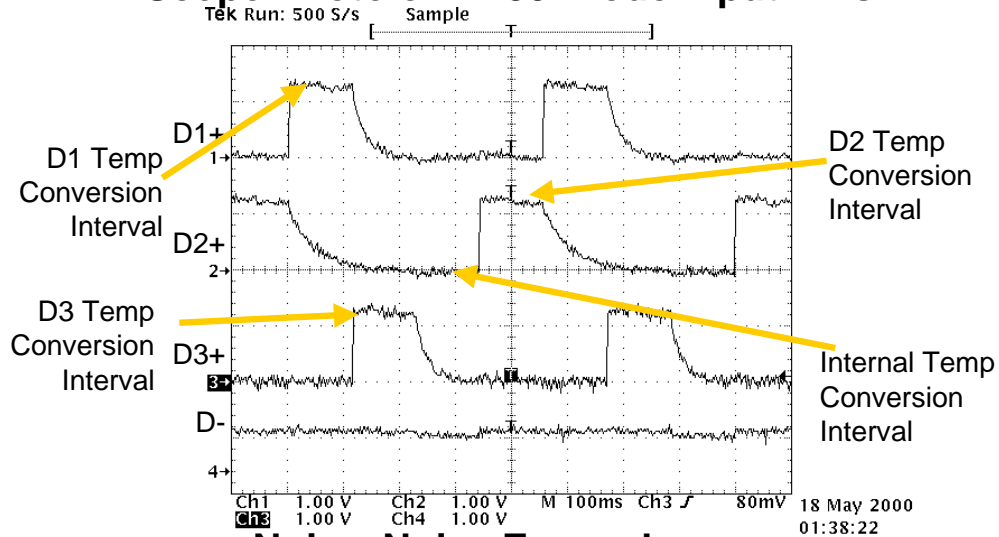

**Noise, Noise Everywhere ...**  
**How can an RDTs Resolve  $100\mu\text{V}/^\circ\text{C}$  signals?**

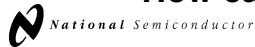

Analog Applications 51

Noise, noise everywhere...let's look at what's actually going on here. The LM83 is sequentially sampling each input. Each diode is biased on at a different point in time. The pedestals in the top three waveforms are the time interval when that particular RDTs input is being monitored. When all three diode inputs are at zero, the internal diode is being sampled. Notice that the noise doesn't change much from channel to channel. See how stable the D- input is. There is only a a delta when going from and to an internal measurement. The slight change in the diode pedestal level is caused by the 10x and 1x current change during the diode measurement. This delta in DC voltage caused by the 10x to 1x current switching is not noticeable on the D- input. Why? Turn to the next slide...

## IC Topology

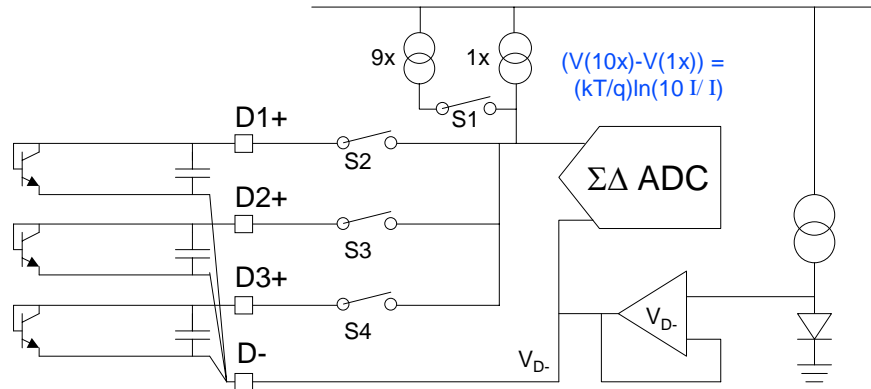

**Single D- input lowers pin count and reduces Total Cost of Ownership!**



Analog Applications 52

Without sacrificing noise performance, the LM33 allows multiple diode inputs to share a single D- input pin. This architecture maximizes the number of remote diode inputs the part can have. The D- “input” is forced to 0.7V by the  $V_{D-}$  amplifier. This amplifier ensures that the D- input is a very low impedance node.

Note the capacitors on each channel’s input. These capacitors’ low impedance at high frequencies ensures that any high frequency noise injected on a D- or D+ input appears as a common mode signal to the ADC. The ADC differentially samples the D+ and D- pins, therefore any common mode signal will be rejected to the CMRR of the ADC. The low impedance output of the  $V_{D-}$  amplifier, in conjunction with the external filtering capacitors, limit the amount of noise that is injected.

In operation, a sample is taken with 10x current forced through the diode under test. The 9x current is then switched off and a differential measurement is taken with the 1x current. The difference between these two measurements is proportional to temperature as shown in the equation above. To cancel out any low frequency noise signals that do not appear as common mode signal, 10,000 samples are taken and averaged by the ADC.

## IC Topology

- Inherent impedance mismatch between D+ and D- *could* reduce differential noise rejection...
- But external capacitors short D+ to D- at high frequencies
- And opamp provides stable D- impedance at low frequencies, and as device switches between I and 10I

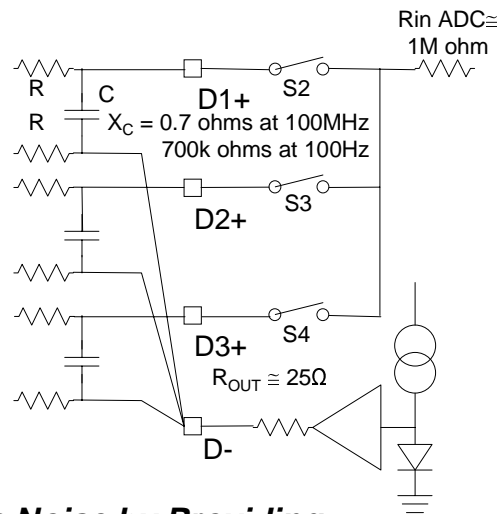

**Op Amp Stabilizes Noise by Providing Similar D- Impedance for I and 10I measurements.**



Analog Applications 53

The D- input has a very low input impedance, while the D+ input impedance is very high. At high frequencies, this impedance mismatch is compensated for by the capacitors between the D+ and D- inputs. Since the capacitor's impedance is inversely proportional to frequency, they effectively short the D+ and D- inputs at high frequencies, forcing any high frequency noise on all the input pins to be identical. At low frequencies, trying to match the noise coupling on D+ and D- inputs is futile. The low impedance output of the VD- amplifier on the D- input forces the noise on all the D- lines to be equivalent and limits the amount of external noise that can be coupled in. Noise coupling between channels on the D- input, therefore, is minimal. The best way to cancel out low frequency noise error is internal filtering, as used in the LM83. Another alternative is to increase the external filter capacitor value, but this will limit the switching speed of the diode biasing current and increase the conversion time, slowing the overall system response time.

# IC Topology

## Reject Noise Even Further with Sigma-Delta ADC Architecture!

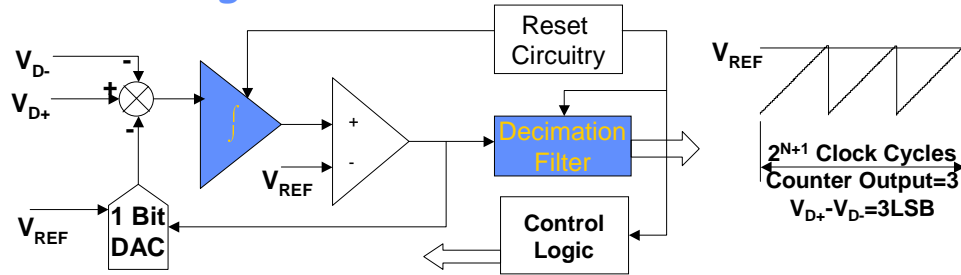

- ADC is reset at beginning of each conversion, providing accurate DC measurement with no residual from previous conversion
- Decimation Filter and Integrator filter noise and allow:
  - auto zeroing for DC signals
  - offset trimming
- $\Sigma\Delta$ 's  $> 10,000x$  over-sampling/averaging provides much better noise rejection than SAR architectures

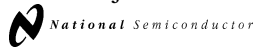

Analog Applications 54

The Sigma-Delta ( $\Sigma\Delta$ ) ADC used in National's temp sensors is a special architecture designed for DC and very low frequency inputs. While some traditional  $\Sigma\Delta$  ADC architectures have problems with DC inputs due to tone generation at certain frequencies (the tone frequency depends on sampling frequency and the input DC level), this special architecture easily handles DC inputs:

- Very high oversampling ratio (OSR): For our  $\Sigma\Delta$  ADC,  $OSR > 10000x$ . Typical  $\Sigma\Delta$  ADC's have OSRs on the order of  $\sim 256x$ . (A new project at Berkeley has has a  $\Sigma\Delta$  ADC with  $OSR = 40000x$ )
- To maximize DC accuracy, the integrators are reset after every conversion. Normal  $\Sigma\Delta$  ADC's don't do this.
- A first-order sinc filter is used as the decimating filter. This allows offset trimming and autozeroing for DC applications.

$\Sigma\Delta$  ADC's are very accurate, but slow compared to a SAR architecture.  $\Sigma\Delta$  ADC's can achieve  $>20$  bits of accuracy, where SAR ADC's are only practical up to about 12-bits, since they are limited by their DAC linearity. The SAR is a faster architecture, but speed is unnecessary for slow changing signals like temperature.

This particular  $\Sigma\Delta$  ADC inherently averages the input, giving better noise rejection.

# Noise Performance Torture Test 1

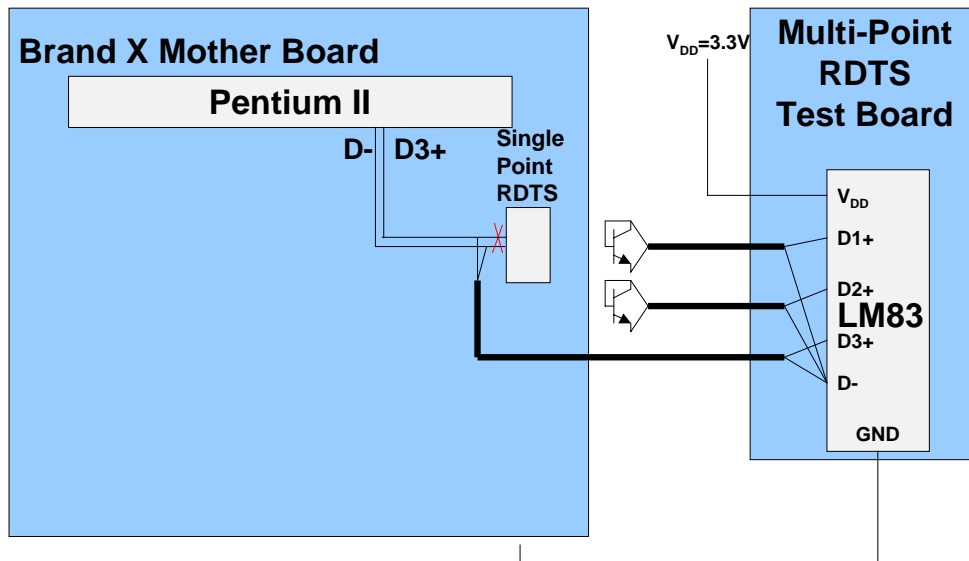

This is all wonderful in theory, but how does it work in the real world? We did some tests. A Pentium processor doing continuous real-time, high-speed 3D-rendering generates a lot of thermal changes, and a PC motherboard is a pretty noisy environment. How much of the Pentium's signal (D3+) and the motherboard's noise will show up in the D1 and D2 channels?

Experiment Conditions:

2 RDTs channels go to 2 diode-tied MMBT3904 transistors

3rd Channel tied to diode on a Pentium® II in a PC

PC running graphics application under Windows

Connection using 15" braided ribbon cable

No ground shielding

A separate PC logged readings to ensure data is recorded while the noisy application is running

An HP 3631A bench power supply provided external power to the LM83

# Noise Performance Torture Test 1: Results

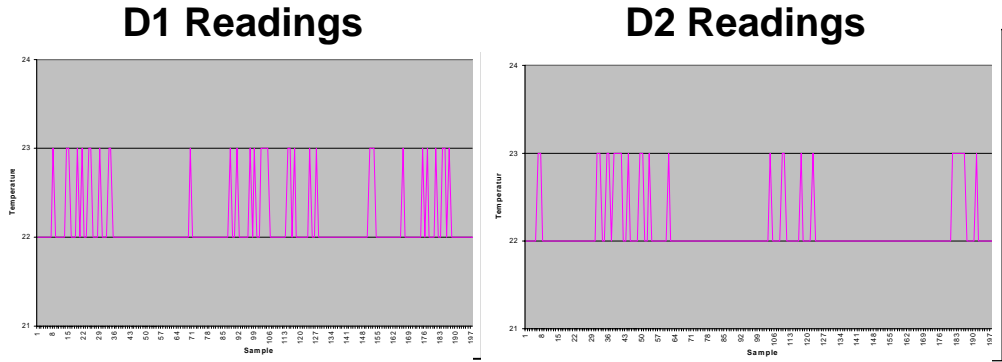

***All readings are 22°C or 23°C.  
There is no noise coupled!***



The two remote diode channels show only ADC quantization noise (flipping back and forth between two adjacent codes). But this wasn't really *that* torturous a test...we can do better!

## Noise Performance Torture Test 2

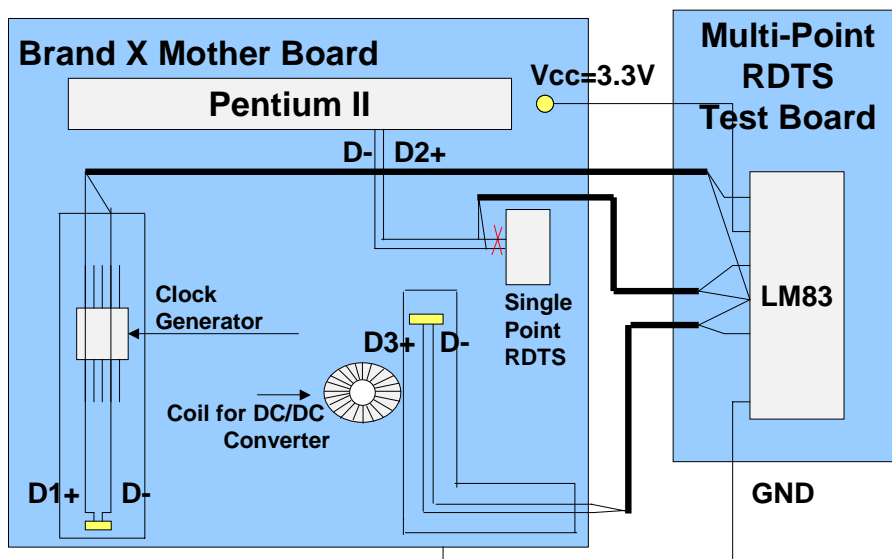

This time we used a 400MHz Pentium II processor motherboard, drew the power supply for the LM83 from the PC's 3.3V supply, and ran our other two remote diodes all over the motherboard. Conditions:

Experiment Conditions:

D1 is placed on a flex circuit that is taped over the Pentium's clock generator chip (the SG577D from International Micro Circuits)

D3 is placed on a flex circuit that is wrapped and taped around the inductor of a switching DC/DC power converter!

3rd Channel tied to diode on a Pentium® II in a PC

400MHz Pentium II was running graphics application under Windows

Connection using 15" braided ribbon cable to the flex circuit as well at the Pentium II thermal diode traces (the single RDTS device traces were cut very close to the RDTS IC)

No ground shielding

A separate PC logged readings to ensure data is recorded while the noisy application is running

The power for the LM83 was tapped off the Pentium II mother board.

## Noise Performance Torture Test 2

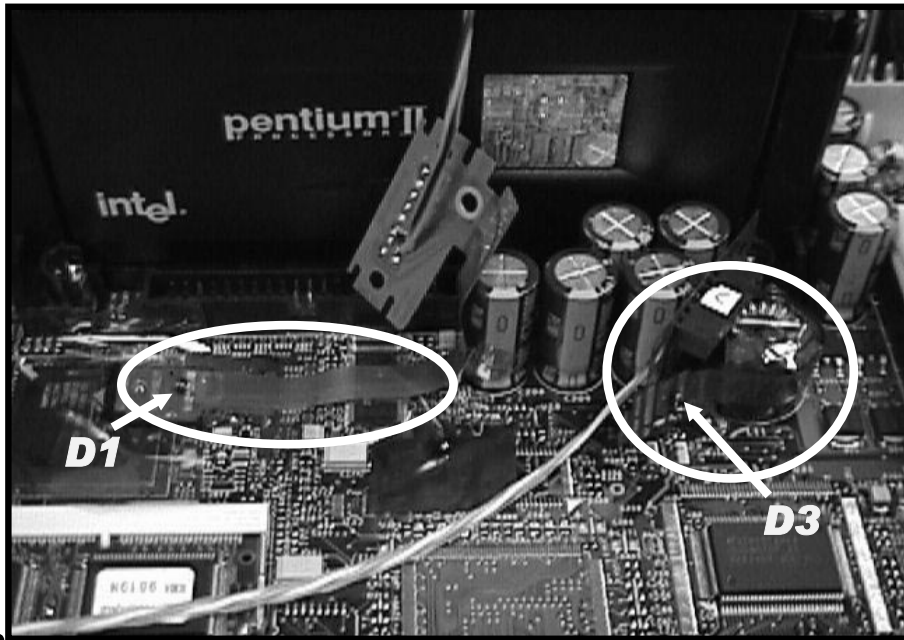

 National Semiconductor

Analog Applications 58

We're not kidding!

## Noise Performance Torture Test 2

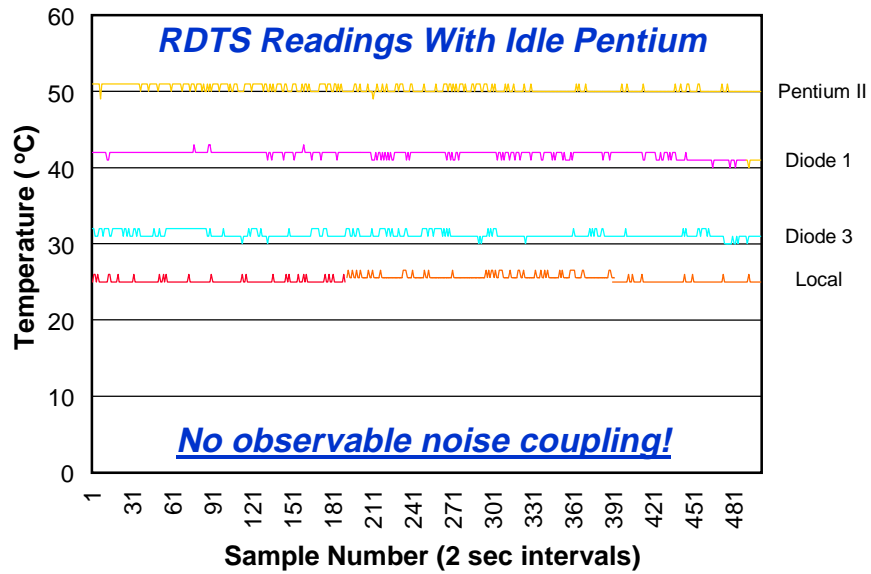

With the Pentium idling, there's no observable noise coupling. Here we show approximately 500 samples taken at 2 second intervals. The actual temperature reading is on the y axis.

## Noise Performance Torture Test 2

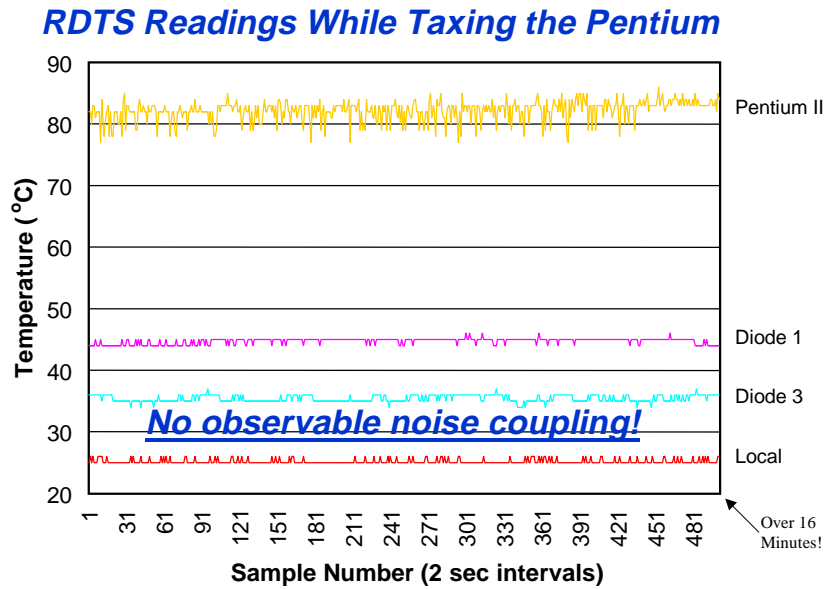

When running the CPU-intensive 3D rendering software, all readings are still essentially noiseless – on Diodes 1 and 3 there's no noise greater than the quantization noise of the ADC riding on top of the low frequency temperature change that takes place over the 16 minute-long test period. The Pentium II reading may appear to be noisy, but it's hard to tell whether the noise is caused by thermal variation of the die or substrate noise coupling into the Pentium II's thermal diode. Notice how the other channels, Local, Diode 1 and Diode 3, are not affected by the third noisy channel.

## Noise Performance Torture Test 3

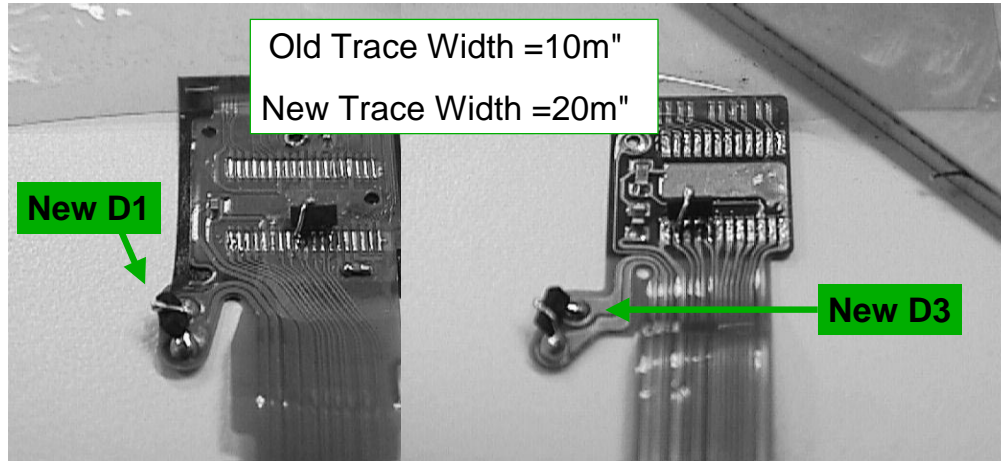

### *Does Trace Width Matter?*

The final question we wanted to answer was the question of trace length. Would wider, lower inductance, lower impedance traces between the remote diode and the LM83 affect noise in any way? We doubled the width of the traces...

## Noise Performance Torture Test 3

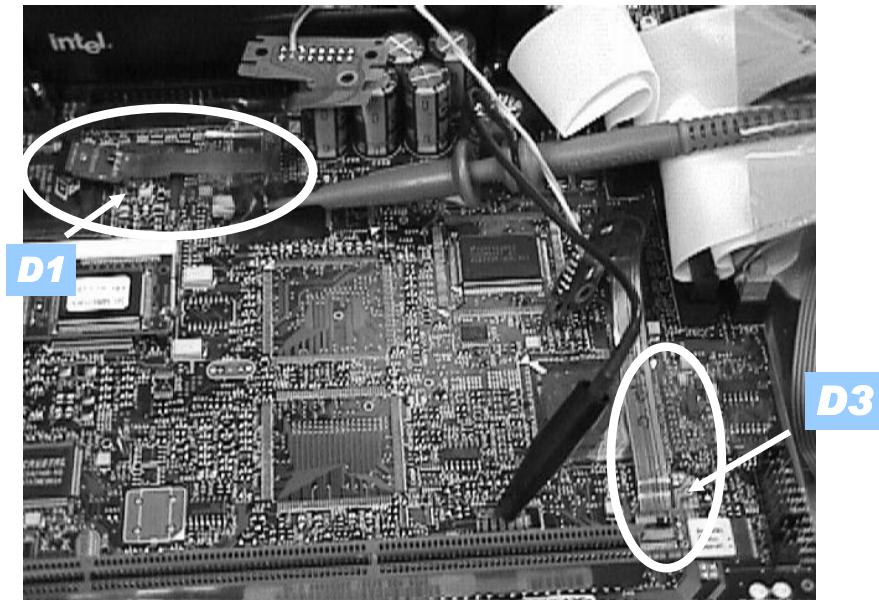

Here's the layout for Test 3. Notice that we moved Diode 3 to an area of the board that was not noisy.

# Noise Performance Torture Test 3

*RDTs Readings While Taxing the Pentium using Fat Traces*

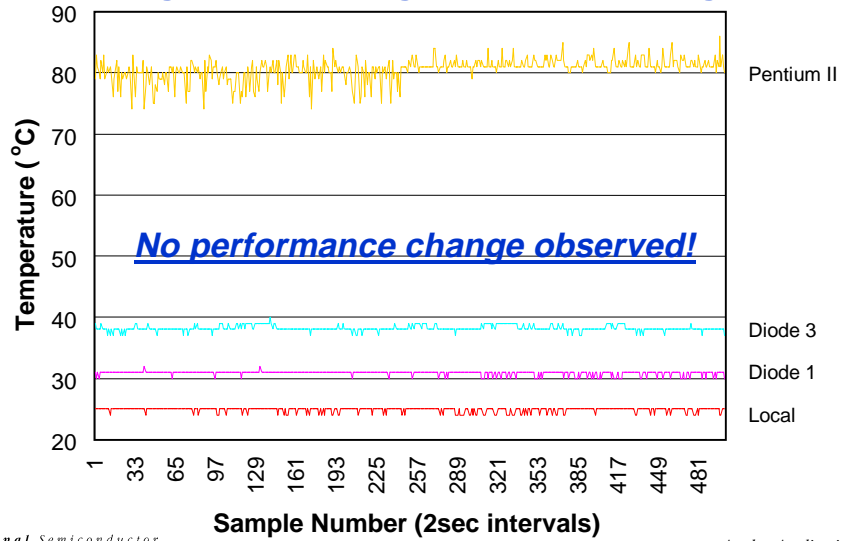

No change! The Pentium II signal level change mid-stream is caused by the random nature of the 3-D graphics software that was being used for the experiments.

## Summary

- There are few places or products so small that they can hide from our tiny temp sensors
- Three RDTS's can be monitored by one IC without loss of performance
- Circuit Topology Can Squash Noise
- Outrageous Routing with Low Noise

## **Collateral:**

- <http://www.national.com/appinfo/tempsensors>
  - info on multiple RDTS
  - RDTS Data sheets:  
LM82, LM83, LM84, LM87,  
SuperI/O(PC87365, PC87366)