



1.0 Scope

This application note provides guidelines for designing with the LMX9830 Bluetooth® serial port module, particularly for critical aspects of the PCB layout. The guidelines have been organized in a simple flow that walks you through the first steps on what documentation to review, key design considerations and then final steps of certification and production. Figure 1 summarizes the product design flow.

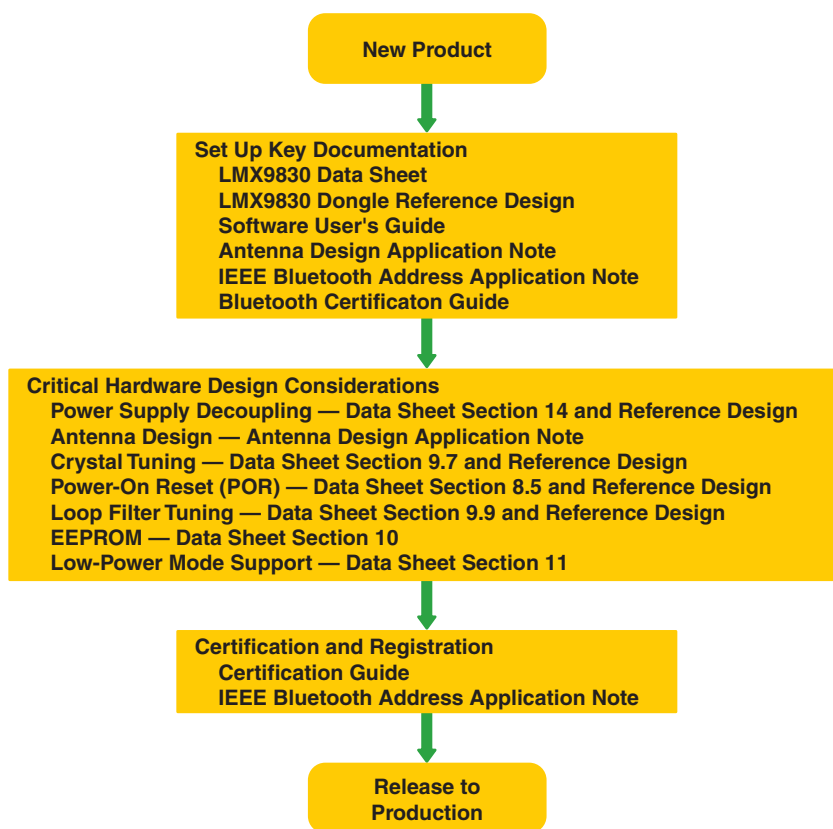

Figure 1. Product Design Flow

Table of Contents

1.0	Scope	1
2.0	Introduction	3
3.0	Product Design Flow	3
3.1	Documentation	3
3.2	Key Design Considerations	3
3.3	Certification and Registration	3
4.0	Design Flow Details	3
4.1	Documentation Structure	3
4.2	PCB Design	4
5.0	Certification and Production	7
5.1	Expected Results	7
5.2	First Prototype Checklist	11
5.3	Most Common Design Errors	11
5.4	Product Certification	11
6.0	References	12

2.0 Introduction

The National Semiconductor LMX9830 Bluetooth Serial Port module is a highly integrated Bluetooth 2.0 baseband controller and 2.4 GHz radio, combined to form a complete small form factor (6.1 mm × 9.1 mm × 1.2 mm) Bluetooth node. All hardware and firmware is included to provide a complete solution from antenna through the complete lower and upper layers of the Bluetooth stack, up to the application including the Generic Access Profile (GAP), the Service Discovery Application Profile (SDAP), and the Serial Port Profile (SPP). The module includes a configurable service database to fulfill service requests for additional profiles on the host.

The LMX9830 is pre-qualified as a Bluetooth Integrated Component. Conformance testing through the Bluetooth qualification program enables a short time to market after system integration by insuring a high probability of compliance and interoperability. Based on National's CompactRISC® 16-bit processor architecture and Digital Smart Radio technology, the LMX9830 is optimized to handle the data and link management processing requirements of a Bluetooth node. The firmware supplied in the on-chip ROM offers a complete Bluetooth (v2.0) stack including profiles and command interface. This firmware features point-to-point and point-to-multipoint link management and supports data rates up to the theoretical maximum over RFCOMM of 704 kbps (Best in Class in the industry). The internal memory supports up to 7 active Bluetooth data links and one active SCO link.

3.0 Product Design Flow

3.1 Documentation

- LMX9830 Data Sheet [1]
- LMX9830 Dongle Reference Design and Layout [2] [7]
- Software User's Guide [3]
- Bluetooth Antenna Design Application Note [4]
- IEEE Bluetooth Device Address Documentation [5]
- Bluetooth Certification Guide [6]

3.2 Key Design Considerations

- *Power Supply Decoupling*—refer to the data sheet [1] and reference design schematics and layout [2].
- *Antenna*—refer to the antenna design application note [4].
- *Crystal*—refer to the data sheet [1].
- *Power-On Reset (POR)*—refer to the data sheet [1].
- *Loop Filter Tuning* - refer to the datasheet [1] and LMX9830 Dongle reference design documents [7].
- *EEPROM*—refer to the data sheet for the NVS contents [1].
- *Low-Power Mode*—refer to the data sheet [1].

3.3 Certification and Registration

- Bluetooth Certification Guide [6]
- *Bluetooth Device Address Management*—refer to the IEEE Bluetooth device address application note [5]

4.0 Design Flow Details

4.1 Documentation Structure

4.1.1 Design Documents

- *LMX9830 Data Sheet*—contains key performance details regarding the device, pin description, functional details, programming details, package information, and application information.
- *LMX9830 Dongle Reference Design and Layout*—a design example with circuit schematics and PCB layout. It is strongly recommended to use the reference design documentation to complete the layout for the LMX9830. Reference design files (Gerber) and Bill of Materials are all provided on the reference design CD. These files can easily be imported into schematic capture/layout design packages such as Orcad and PADS.
- *Software User's Guide*—reference for implementing the LMX9830 module into a system. A getting started session gives a very detailed entry point for starting software development. The Advanced Usage section describes all features and configuration parameters in detail and gives examples for using the LMX9830 as an active Bluetooth node. Finally all commands and events are listed and explained in the command section.
- *Bluetooth Antenna Design Application Note*—contains detailed information about the design of the Bluetooth antenna including matching to the module and a list of antenna component suppliers.

4.1.2 Certification and Production Documents

- *Bluetooth Certification Guide*—best practices and details for obtaining Bluetooth qualification and also regulatory certification such as FCC or CE that is required for all designs before entering the production stage.
- *IEEE Bluetooth Device Address Documentation*—information on obtaining a unique Bluetooth device address from the IEEE, including the procedure and costs.

4.2 PCB Design

The following section discusses the layout requirements for the PCB. Figures 2, 3, and 4 are taken from the LMX9830 UART buffer Dongle reference design. Capital letters mark critical areas which are discussed further in Section 4.2.4.

4.2.1 Schematic

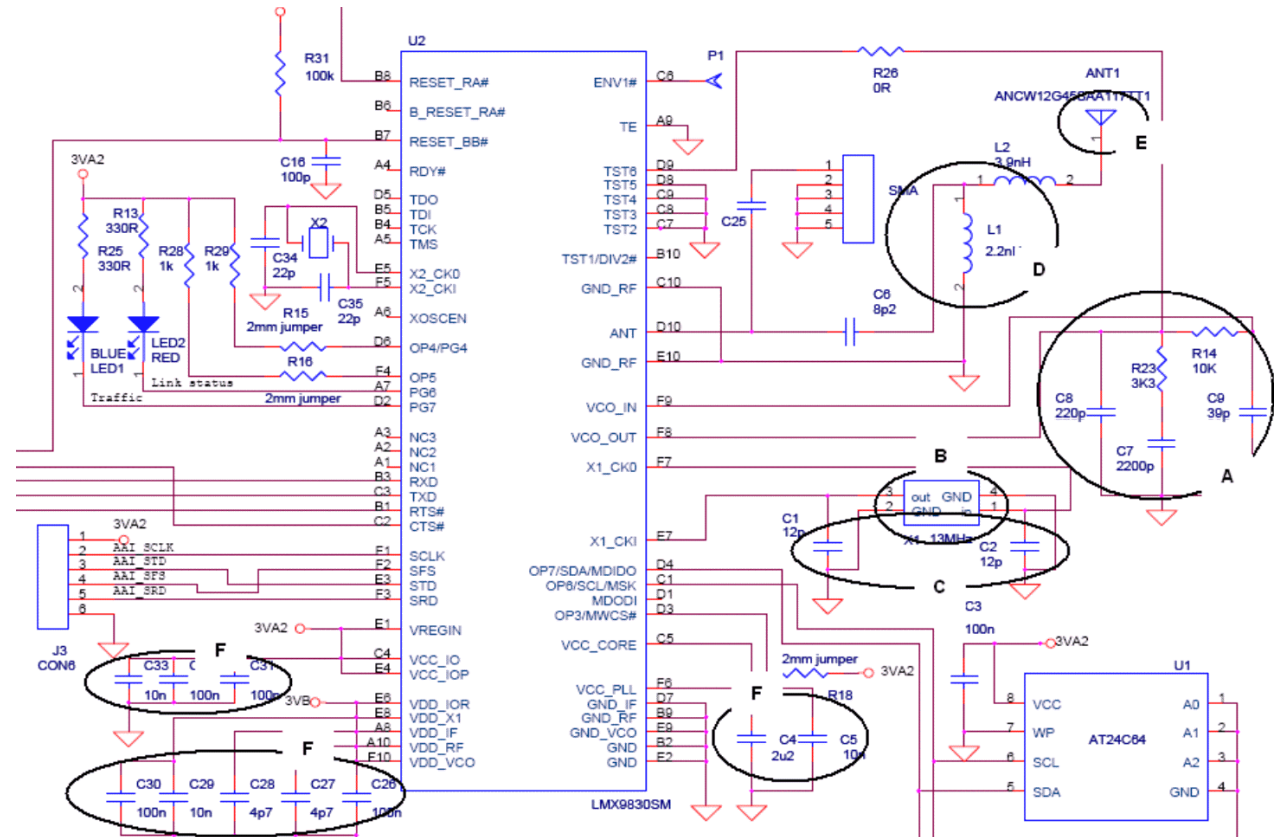

Figure 2. Example Schematic with Critical Areas Indicated

4.2.2 Layout

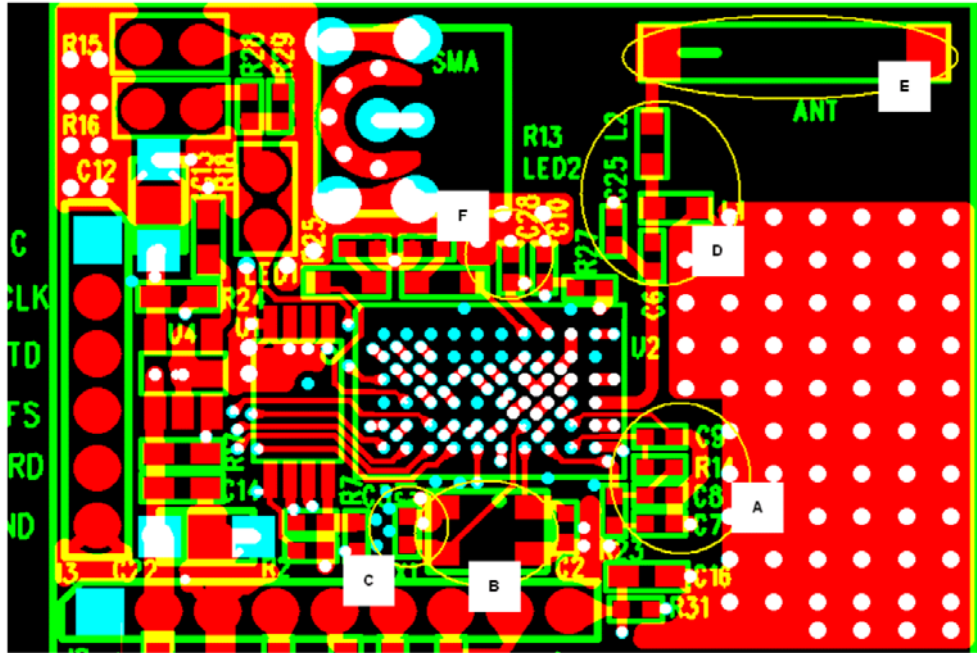

Figure 3. Example PCB Layout with Critical Components Indicated

4.2.3 Grounding

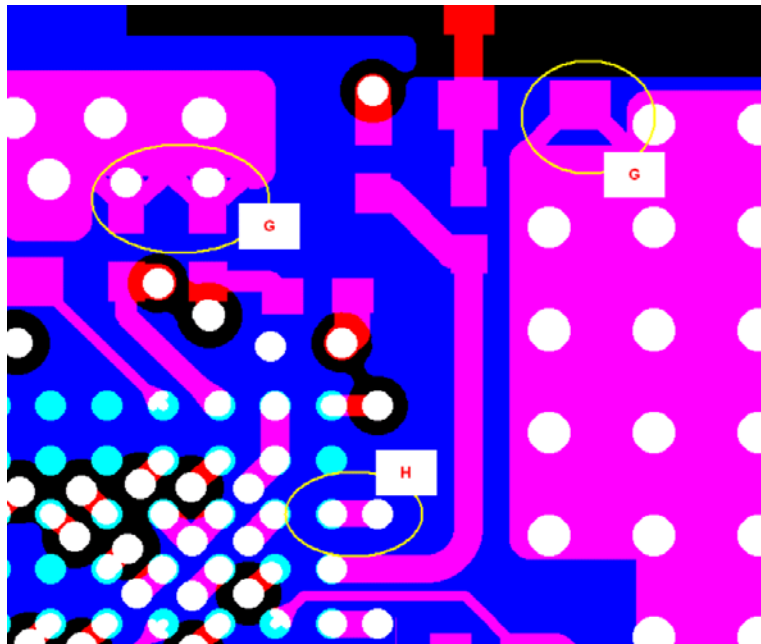

Figure 4. Example Ground Layer Design with Critical Features Indicated

4.2.4 List of Critical Components and Features

Table 1. Critical Areas

Critical Area	Description
A	Loop filter between PLL_OUT and V_tune. This is the external 3rd order loop filter for the LMX9830 PLL. Its design is key to the overall performance of the device. Refer to the LMX9830 data sheet [1], Section 9.7.5. This is the most critical part of the design. It is important to match layout and components for this circuit to the reference design documents. Further tuning can be done to ensure that performance is optimized.
B	Crystal oscillator. This forms part of the clock for the radio and baseband. Because this is a large source of noise, a crystal with jitter less than the specified datasheet limit and <20 ppm tolerance is required. Refer to LMX9830 data sheet [1], Section 9.7.1.
C	Load capacitors for the crystal. These fine-tune the frequency of the oscillator to make the transmitted frequency error <75 kHz, in order to comply with the Bluetooth specification. High tolerance capacitors (<5%) are recommended to achieve good part-to-part stability.
D	Antenna matching network and blocking capacitor. The antenna can be a source of ESD and therefore the module should be protected. A blocking capacitor between the module and the antenna prevents any DC voltages on the antenna being applied directly to the module, thus preventing ESD damage. The blocking capacitor can be placed by itself or, when necessary, be part of a matching network to improve power transfer to the antenna. If used by itself then typically 4pF to 5 pF should be used for lossless transmission at 2.4 GHz. Refer to Bluetooth Antenna Design Application Note [4], Section 4.0.
E	Antenna. Several designs and types are available. Figure 3 shows the placement of a chip ceramic antenna. A cheaper but larger solution is to use a Printed Inverted-F Antenna (PIFA) which is formed using micro-strip traces, making it very inexpensive to manufacture. Refer to the Bluetooth Antenna Design Application Note [4].
F	Decoupling capacitors on power supply pins. Capacitor values should be calculated based on the magnitude of the voltage ripple and the frequencies present. Single, double, or triple arrangements may be used. These capacitors must be placed as close to the module power supply pins as possible for maximum effect.
G	Component to surface ground layer. A component which is to be grounded should not be soldered directly to a ground plane because the large heat dissipation will give an unsatisfactory solder joint. Therefore a component pad should be used and two short tracks used to minimize inductance to ground.
H	Track length from a pin to grounded via. A pin which is connected to a ground via should use a short track to minimize inductance.

4.2.5 Other Considerations

- Ideally, a decoupling capacitor pair should be used per VCC pin of the device, though single capacitors may be used in some cases without degrading performance significantly.
- Shielding around the Bluetooth area may be needed when in very close proximity to an interference source along with a blocking filter on the antenna.
- One solid ground plane should be used for digital and RF.
- A 50-ohm trace is needed for RF input/output. Programs such as AppCad or LineCalc can assist in the determination of the required width of the trace.
- Do not route digital signals under the radio, because this causes cross-talk and degrades performance, especially for out-of-band blocking.
- A 32.768-kHz oscillator may be used to support lower power mode. The modular structure of the LMX9830 allows firmware to shut-down unused modules such as the radio LLC and UART interface. Refer to the data sheet [1] for further information, Section 9.7.3.

5.0 Certification and Production

5.1 Expected Results

Once the design is completed and boards have been assembled, testing can start. Bluetooth test sets are typically used to evaluate performance, with several suitable models being available. The following plots were collected using an Anritsu 8852A. Additional plots below are collected with standard spectrum analyzers.

Figure 5 shows the frequency deviation due to modulation, which is measured during Bluetooth qualification. The payload deviation is used to assess whether the device meets the specification.

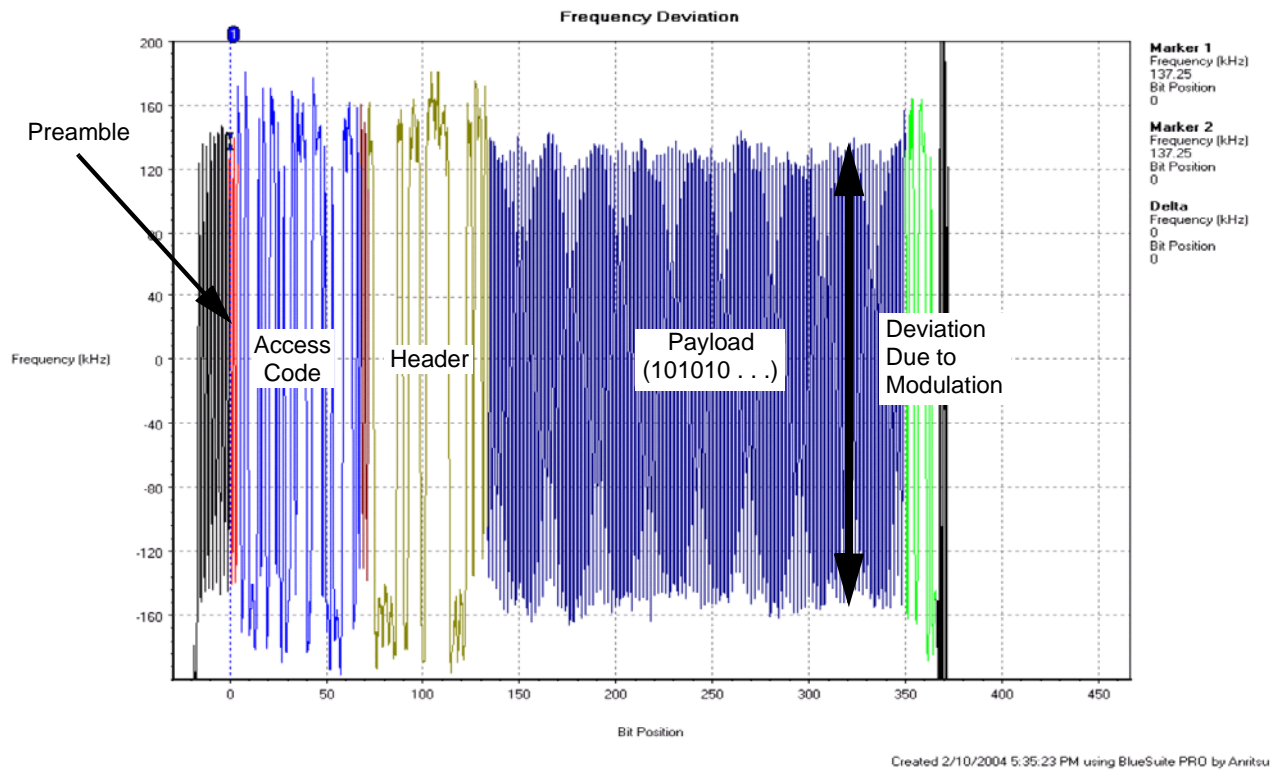

Figure 5. Deviation Due to Modulation

Figure 6 is an eye diagram, which shows three features of the transmitter:

- The resolution or clarity of the diagram itself is proportional to the amount of noise present within the transmit spectrum. A noisy spectrum will have a much smaller eye opening.
- The center crossing point shows the frequency error.
- The opening of the eye is the payload deviation.

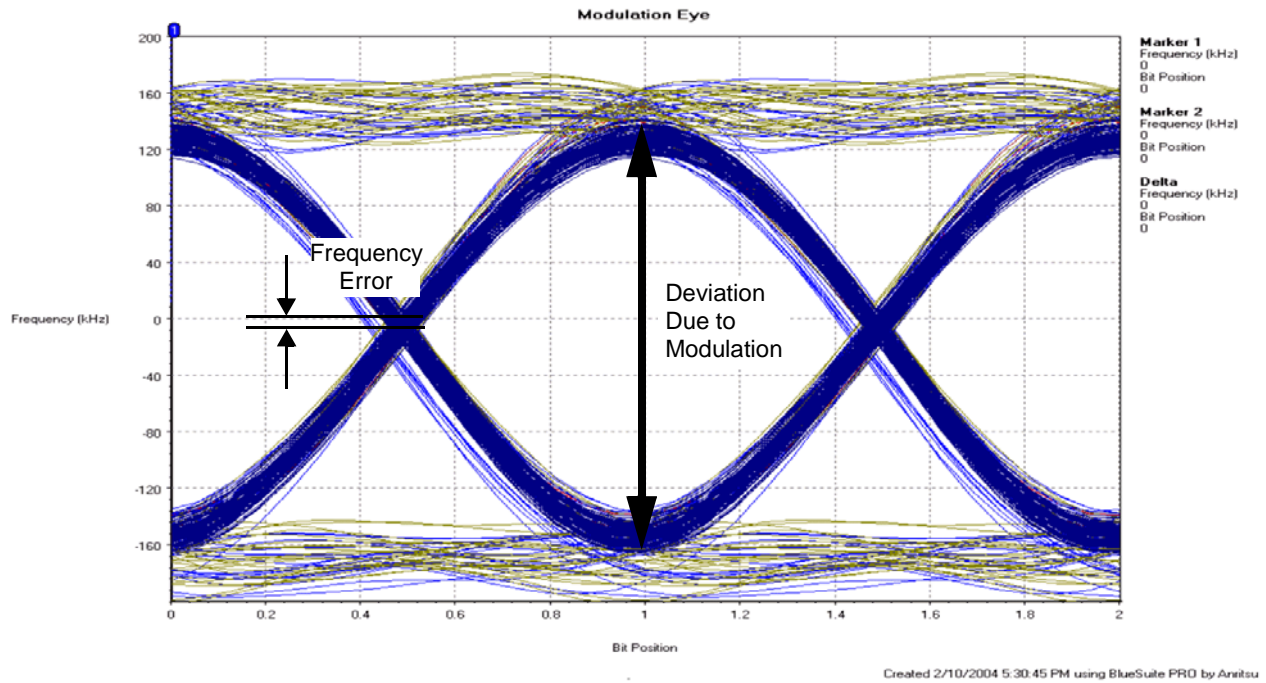
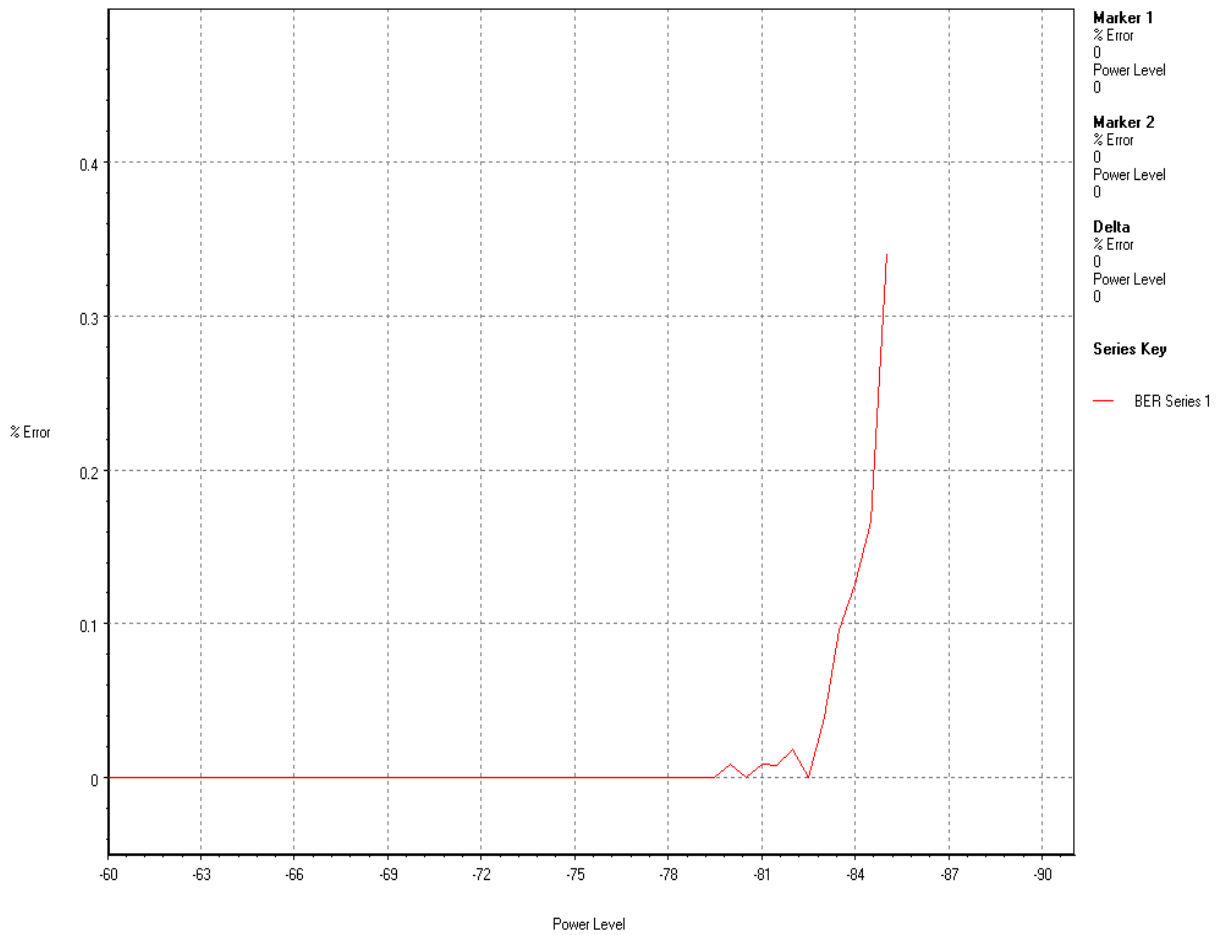

Figure 6. Eye Diagram

The Frame Error Rate (FER) and the Bit Error Rate (BER) are a measure of receiver quality. Figure 7 shows typical BER performance. The Sensitivity Specification states that at -70dBm the BER should be better than 0.1%. The BER and FER should both be close to 0% when signal level is >-70 dBm. The BER should only exceed 0.1% at <-80 dBm.



Created 3/20/2006 10:34:06 AM using BlueSuite PRO by Anritsu

Figure 7. BER vs. Input Power Level (dBm)

The modulation spectrum in Figure 8 shows the 20 dBc Bandwidth is less than 1000 kHz, as required by the Bluetooth specification. The limit prevents interference with neighboring channels.

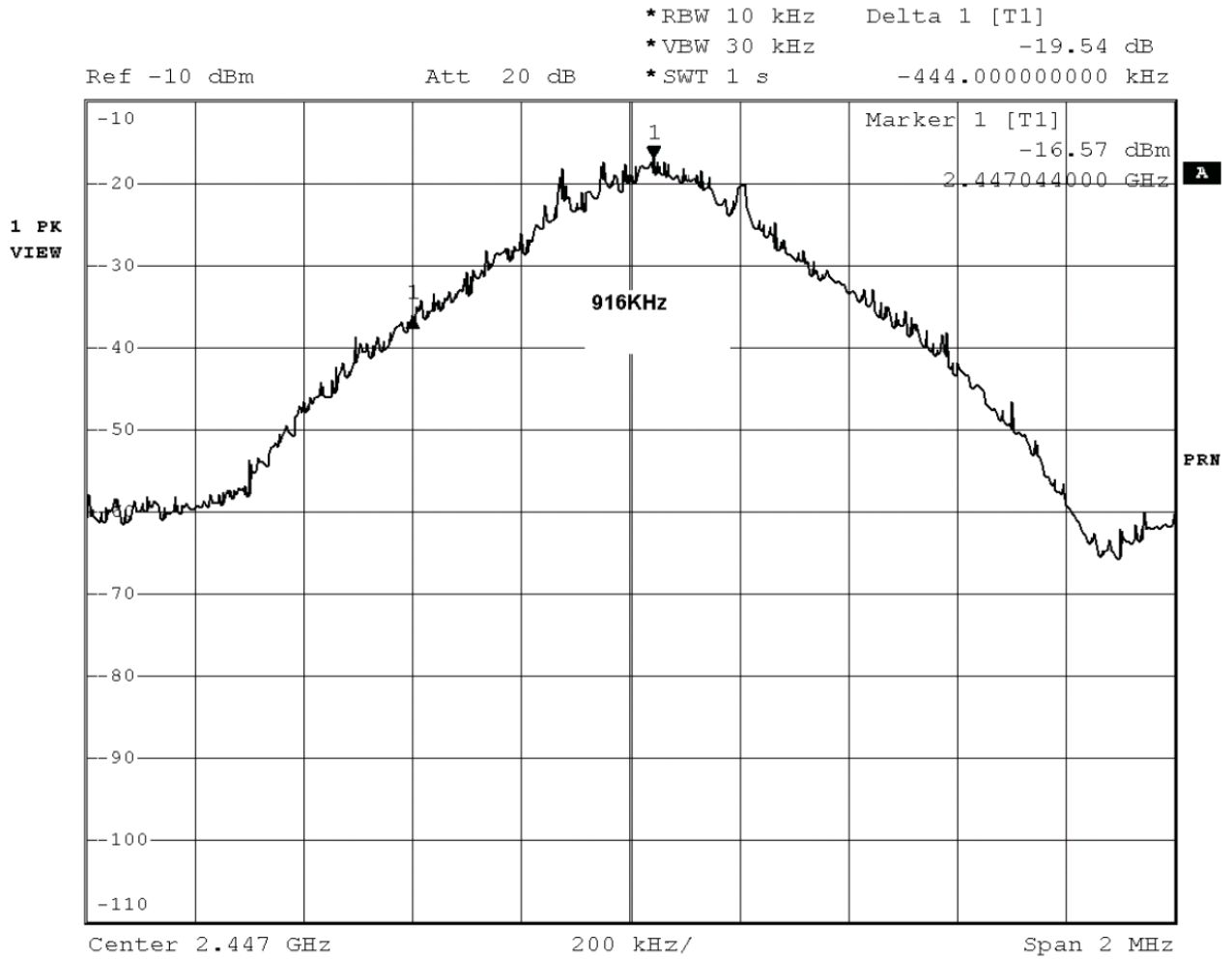

Date: 29.JUL.2005 13:13:46

Figure 8. Transmit Spectrum

5.2 First Prototype Checklist

If the expected results cannot be obtained from the first prototypes, the following points should be checked:

- Test at least 3 to 5 boards to make sure the failure is consistent with the design and not board-dependent.
- Inspect the boards under a PCB microscope, checking for dry or short-circuited joints.
- Check power supply, digital I/O, and radio are within the data sheet specified range.
- X-ray can be used to inspect the quality of soldering under the module. Too little solder will form dry gaps, excess will lead to overspill and shorts between pins.
- Check that the crystal is turning on during power-up using a high-impedance probe. Check that the frequency is ± 240 Hz of the desired frequency. The crystal can be tuned using internal registers or the load capacitors.
- Check the power-supply noise ripple on the VCC pins is within 15 mVp-p. A large capacitor on the output of the LDO will smooth low-frequency ripple.
- Loop filter tweaks may be required if performance measurements are generally poor. Refer to the data sheet for details.
- Antenna matching may be required to improve radiated sensitivity and power, therefore range. Refer to the Bluetooth antenna design application note.
- A front-end filter (either LC or ceramic) may be required for additional blocking margin. Refer to the Bluetooth antenna design application note.

5.3 Most Common Design Errors

These are some of the more common errors when designing with the LMX9830.

5.3.1 Non-Compact Design

When there is more than enough space on the PCB which must be of a certain shape and size to conform to the application, some designers tend to spread the external components over a larger area than is required. This is a mistake. Though there may be space available, the external components such as loop filter, decoupling capacitors, crystal, etc. must be placed as close to the LMX9830 as possible, otherwise degraded performance due to unnecessary line parasitics will result.

5.3.2 Poor Grounding

Not using enough ground vias or ground lines that are too thin and long is a common error. Long tracks are inductive, and high-frequency currents do not get down to the ground plane fast enough, resulting in cross-coupling and spurious emissions.

5.3.3 No Antenna-Matching Network or External Filter

Though a purchased antenna may work well on its test PCB, it may not have the same performance on the final design PCB. A common mistake is to forget the matching network or room for filtering that will add versatility to the design and allow for antenna tuning and better blocking performance.

5.3.4 Badly Tuned Crystal

Like the antenna, the crystal oscillator's frequency is subject to pull when placed on the final application PCB due to parasitic stray capacitance. Not tuning the crystal on the final design is therefore a common cause of initial poor performance.

5.4 Product Certification

Refer to the Bluetooth certification guide which describes the steps and preparation needed to get full regulatory and Bluetooth certification for a new product, including lists of required tests and detailed procedures. The key steps required to achieve certification, as described in the certification guide, are:

1. Become an Adopter or Member of the Bluetooth SIG.
2. Review the design guide, data sheet and complete documentation package for a selected National Semiconductor product.
3. Design the schematic and component layout. The critical grounding and decoupling required for the radio must be studied in detail.
4. Generate the schematic and layout Gerber files for the final application.
5. Compare schematics and layout files to details in datasheet, reference designs and application notes.
6. Implement the design changes as agreed in the review.
7. Production of first prototypes (between 10 and 20 units).
8. At least five units must be tested fully over the temperature range.
9. Any failure or marginal pass of the specification must be corrected by component change or layout modification.
10. Test the DUTs again to verify that all parameters are within specification.
11. Prepare three "golden units" for the BQTF, two with antenna connectors and one with an original antenna.
12. Select the BQTF and prepare documentation for DUTs.
13. Submit the documentation and DUTs to the BQTF for regulatory and Bluetooth qualification tests.
14. Product will be listed on the official Bluetooth web page as Bluetooth compliant when all test cases have passed.
15. Release product to manufacturing.

6.0 References

Ref.	Title	Type	File Name
1	LMX9830 Bluetooth Serial Port Module	Data Sheet	LMX9830DS.pdf
2	LMX9830 Dongle Hardware User Guide	User Guide	LMX9830DONGLE Hardware User Guide.pdf
3	LMX9830 – Software Users Guide	User's Guide	LMX9830_SW_UG.pdf
4	Bluetooth Antenna Design	Application Note	Bluetooth Antenna Design.pdf
5	Bluetooth Device Address for the LMX9830	Application Note	BD_ADDR AN.pdf
6	Bluetooth Certification Guide	Application Note	BT Cert Guide Complete.pdf
7	LMX9830 Dongle Reference Design ^a	Design Files	LMX9830Dongle without UART Buffer.DSN LMX9830DONGLE PADS file.pcb LMX9830DONGLE_BOM_without UART Buffer.xls

a. Dongle without UART buffer is a more accurate form factor design. UART buffer is used for 5V interface to PC for testing only. UART buffers is not needed for 3V designs.

National does not assume any responsibility for use of any circuitry described, no circuit patent licenses are implied and National reserves the right at any time without notice to change said circuitry and specifications.

For the most current product information visit us at www.national.com.

LIFE SUPPORT POLICY

NATIONAL'S PRODUCTS ARE NOT AUTHORIZED FOR USE AS CRITICAL COMPONENTS IN LIFE SUPPORT DEVICES OR SYSTEMS WITHOUT THE EXPRESS WRITTEN APPROVAL OF THE PRESIDENT AND GENERAL COUNSEL OF NATIONAL SEMICONDUCTOR CORPORATION. As used herein:

1. Life support devices or systems are devices or systems which, (a) are intended for surgical implant into the body, or (b) support or sustain life, and whose failure to perform, when properly used in accordance with instructions for use provided in the labeling, can be reasonably expected to result in a significant injury to the user.
2. A critical component is any component of a life support device or system whose failure to perform can be reasonably expected to cause the failure of the life support device or system, or to affect its safety or effectiveness.

BANNED SUBSTANCE COMPLIANCE

National Semiconductor certifies that the products and packing materials meet the provisions of the Customer Products Stewardship Specification (CSP-9-111C2) and the Banned Substances and Materials of Interest Specification (CSP-9-111S2) and contain no "Banned Substances" as defined in CSP-9-111S2.



National Semiconductor
Americas Customer
Support Center
Email: new.feedback@nsc.com
Tel: 1-800-272-9959

National Semiconductor
Europe Customer Support Center
Fax: +49 (0) 180-530 85 86
Email: europa.support@nsc.com
Deutsch Tel: +49 (0) 69 9508 6208
English Tel: +44 (0) 870 24 0 2171
Francais Tel: +33 (0) 1 41 91 8790

National Semiconductor
Asia Pacific Customer
Support Center
Email: ap.support@nsc.com

National Semiconductor
Japan Customer Support Center
Fax: 81-3-5639-7507
Email: jpn.feedback@nsc.com
Tel: 81-3-5639-7560