



LMX9820x Bluetooth™ Serial Port Module: Simply Blue Commander User's Guide

National Semiconductor
 User's Guide
 December 2004
 Revision 1.3

1.0 Scope

The Simply Blue Commander is a tool to send commands to the National Semiconductor® LMX9820x Bluetooth™ serial port module. The software allows monitoring of the ingoing and outgoing traffic on the UART and interprets the events sent back by the LMX9820x.

This user's guide provides software installation procedures, explains the user interface of the program, and gives some general guidelines to configure and use the LMX9820x.

2.0 Requirements and Installation

2.1 BASIC REQUIREMENTS

Additional hardware required:

- LMX9820ADEV or LMX9820ADONGLE Kit
- x86 PC with serial port
- The software requires one of the following operating systems:
 - Microsoft Windows 2000
 - Microsoft Windows XP

2.2 SOFTWARE INSTALLATION

The software is included within the software package for the LMX9820ADEV and LMX9820ADONGLE Kit. The installation files are on the CD included in the kit.

To install the software:

- 1) Insert the kit CD. If the installation does not start automatically, double click *Setup.exe* on the root of the CD drive.
- 2) Click the *Install Software* button. Reference Figure 2-2 on page 2. This will install CRISP, documentation, SB Smart and Simply Blue Commander. Please browse the CD.
- 3) Shortcuts are installed at *Start->Programs->Simply Blue 2.0*. Reference Figure 2-3 on page 2.

2.3 HARDWARE SETUP

The Simply Blue Commander offers a simple interface to send and receive commands and events from an PC to the Simply Blue LMX9820x. The commands are sent over a null modem cable to the board. See Figure 2-1 for the hard-

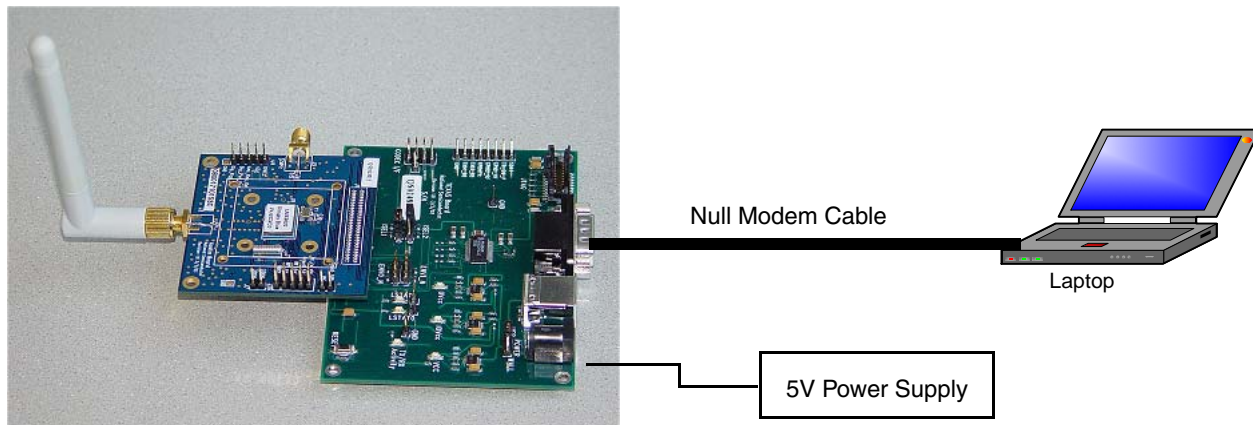

Figure 2-1. PC - Texas Austin Connection

National Semiconductor is a registered trademark of National Semiconductor Corporation.
 Bluetooth is a trademark of Bluetooth SIG, Inc. and is used under license by National Semiconductor.
 For a complete listing of National Semiconductor trademarks, please visit www.national.com/trademarks.

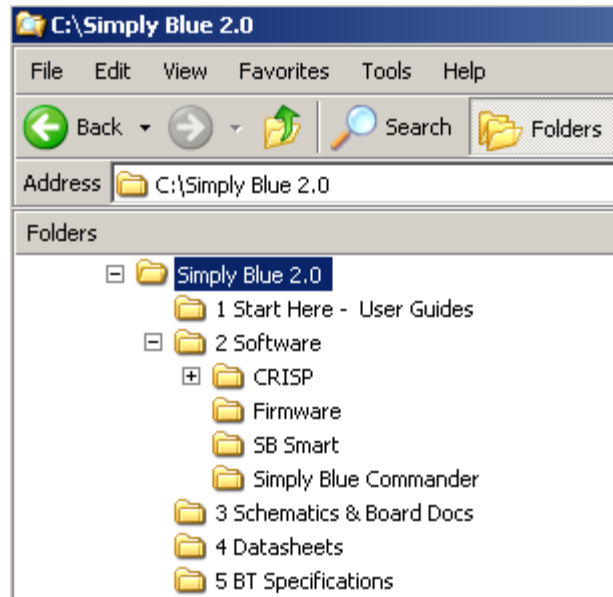

Figure 2-2. Simply Blue Default Directory

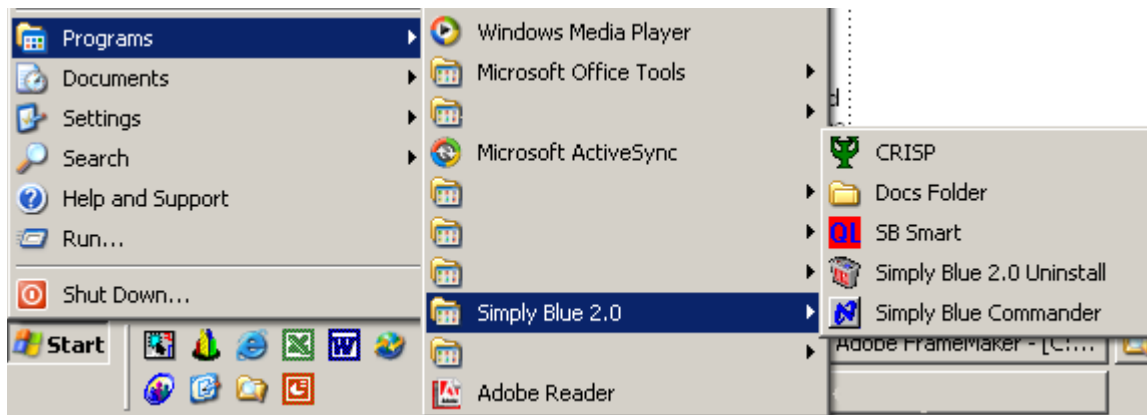

Figure 2-3. Simply Blue Shortcut

3.0 Using the Software

3.1 GETTING STARTED

Starting the Simply Blue Commander the first time will probably cause a transport layer error on the UART (see Figure 3-1). Ignore the message and go on.



Figure 3-1. UART Transport Error (Ignore on First Start)

The program comes up as shown in Figure 3-2. The program can be divided in three parts:

- Command Directory
- Log Window
- Command Line

3.1.1 Command Directory

The Command Directory contains a list of commands sorted into several subfolders. Directories are stored in different files in the installation directory. If the Command Directory is empty on first startup, select "File/Open" in the menu bar. Choose one of the *.dir files. The default directory with all commands is called "Commands.dir".

3.1.2 Transfer Log Windows

The Log Window records incoming and outgoing traffic on the selected UART interface. TX indicates outgoing, RX indicates incoming. On default, after pressing the Reset button on the Texas Austin Kit, you should receive the following feedback from the board:

Rx: Event: SimplyBlue Ready, SW Version: xxxx

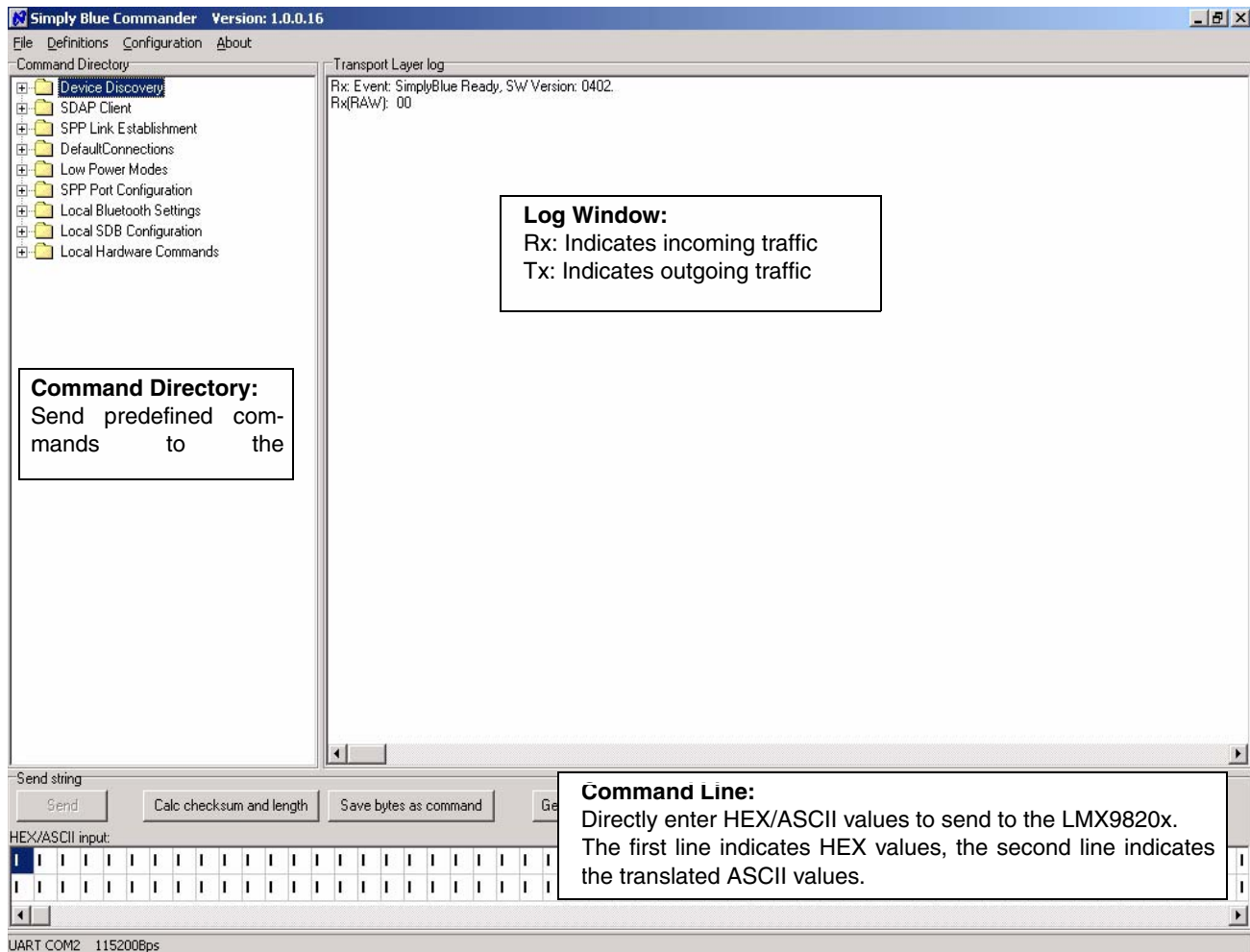

Figure 3-2. Simply Blue Commander Overview

If you do not get this feedback (i.e., Rx: Event: SimplyBlue Ready, SW Version: xxxx), select “Configuration/Transport Layer” in the menu bar as shown in Figure 3-3 and Figure 3-4.

On default the UART settings will be set to 115.2 kbit/s, no parity, 1 stop bit. Choose “Low level driver” and “CTS output flow control”. If you have the correct settings for the UART it should be possible to talk to the board. The best test is to reset the board and wait for the event as described.

Make sure the settings on the Texas Austin board fit with those driver settings. Refer to the *Texas Austin Kit Users Guide* for further details regarding board configuration.

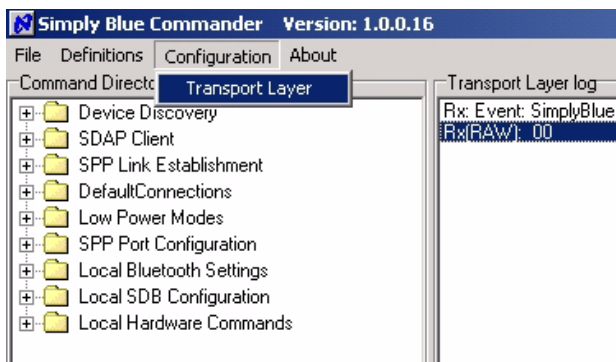

Figure 3-3. Choose Transport Layer

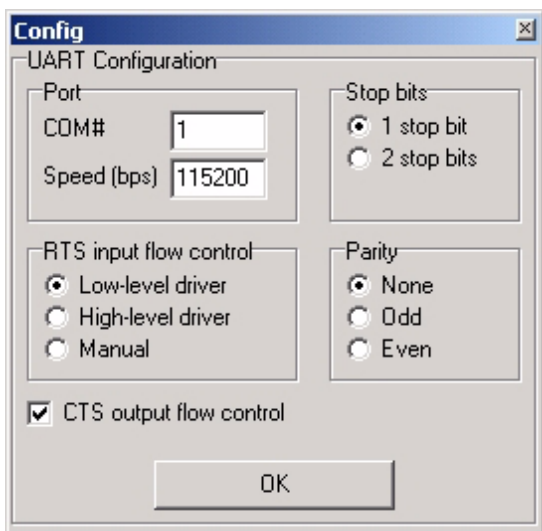

Figure 3-4. UART Configuration

3.1.3 Command Line

The Command Line is split into two lines (see Figure 3-5), one for HEX and one for ASCII. These lines are update linked to each other, meaning as soon as something is typed in the first line it is translated and the other line is filled with the appropriate value. Each field in the first line represents one byte in HEX. Each field in the second line

represents the ASCII character for the value in the appropriate HEX field. Both fields are editable.

This feature is provided to ease the creation of commands including ASCII characters (e.g., Write_local_name).

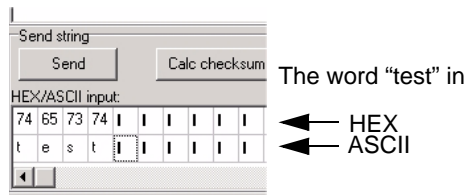

Figure 3-5. Example Command Line

3.2 COMMAND DIRECTORIES

3.2.1 Open/Save Command Directories

The command directories are stored in editable files in the installation directory of the Simply Blue Commander. The file format is *.dir.

The program offers to save modified directories and load them if needed. This feature allows device specific directories and settings in one directory.

Command directories can be opened and stored by selecting “File/Open” or “File/Save”.

3.2.2 Editing Command Directories

It is possible to add or remove existing command folders within one directory. To create a new folder, right-click your mouse within the Command Directory part of the window (see Figure 3-6 and Figure 3-7). To add a new directory click on “New Command Folder”. The “Delete” command can be used for folders and commands.



Figure 3-6. Creating a New Command Folder



Figure 3-7. Enter the Name for the New Folder

3.3 THE LOG WINDOW

The Log Window monitors the incoming and outgoing traffic on the UART interface. The configuration of the Log Window can be performed by a right-click within the Log Window (see Figure 3-8).

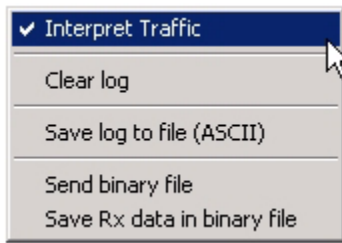

Figure 3-8. Log Window Configuration

3.3.1 Interpreting Traffic

On default, the commands and events are interpreted by the command and translated into user friendly terms. The interpretation can be switched on or off by the configuration dialog.

3.3.2 Clear Log

The log file can be emptied by a function in the configuration dialog.

3.3.3 Store Log Window into File

The configuration allows storage of the complete Log Window and all future traffic within a log file. The ASCII file is called "SimplyBlueCommander.log" and is stored within the installation directory of the program. The function is active until it is changed within the configuration dialog.

3.3.4 Send Binary File

If the LMX9820x is within a link and the transparent option is switched on for the UART, it is possible to send a binary file to the remote device. The device sends the data to the UART without any modifications. To send the file, choose "Send binary file" in the configuration dialog, choose the file, and press OK.

3.3.5 Receiving a File

Typically, the Simply Blue Commander does not store any incoming data in a file. The Log Window only displays them or stores the complete log file within an ASCII file (see Section 3.3.3).

To save incoming data within in a file, enable the "Save RX binary data in file" option. The program will ask for the file name and the directory to save it in.

The option must be enabled BEFORE the sender starts to transmit.

3.4 THE COMMAND LINE

After choosing a command within the Command Directory the Command Line is filled with the actual HEX package associated with this command. The first line shows the actual HEX code of the package. The second line shows the translated ASCII character for that HEX code.

The lines provide the ability to check the actual package with all options and parameters, before actively sending it over the UART.

The translated ASCII value in the second line helps provide recognition for or entering string values like the Local Name.

Note: When Send is pressed, the string within the Command Line is always used. The content of the Command Line changes by selecting another command within the Command Directory.

To save a modified command, use the "Save bytes as command" button.

3.5 CREATING AND SENDING COMMANDS

To send a command to the LMX9820x:

- 1) Find the command within the Command Directory.
- 2) Select the command and left-click it once. This generates the HEX code within the Command Line.
- 3) Modify the parameters within the Command Line to the necessary values.

Upon completion of the steps above, the user has the following options:

- Button "Calc Checksum and length": This checks the modified string and recalculates the length of the data package and the Checksum for the header. For detailed information on the package format refer to the *LMX9820x Bluetooth™ Serial Port Module: Software Developers Guide*. **This command should be used every time before sending it to the LMX9820x. It guarantees that the package header is transmitted correctly.**

Note: The command does not calculate length parameters within the payload (e.g., the length of the name in "Write Local Name"). This has to be counted and modified manually.

- Button Send: This sends the string of the Command Line to the LMX9820x.

Once a command has been modified it can be saved by pressing the button "Save byte as command". The entered string is used as the command name within the Command Directory.

A step-by-step example of changing the "Local Name" with "Write Local Name" is provided next.

Step 1: Choose the command and the command appears in the Command Line.

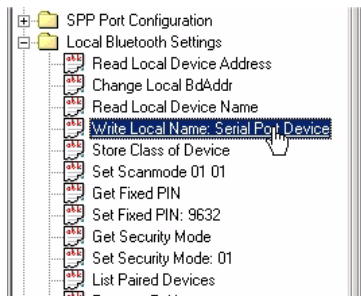

Figure 3-9. Choose the Command

Step 4: Recalculate checksum and length of the package.

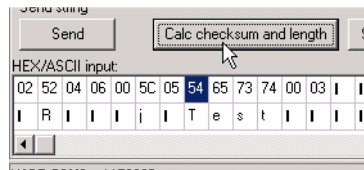

Figure 3-13. Recalculate Checksum

Step 5: Press Send to submit the package to the LMX9820x, then view the result in the Log Window. Status 00 indicates that it was successful.

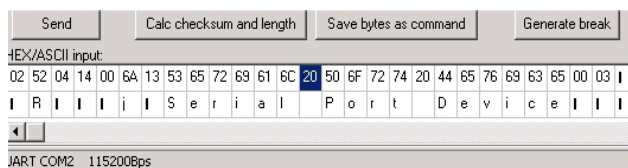

Figure 3-10. Command Line

Step 2: Change the text string "Serial Port Device" to "Test". Typing on the second line automatically fills in the correct HEX values.

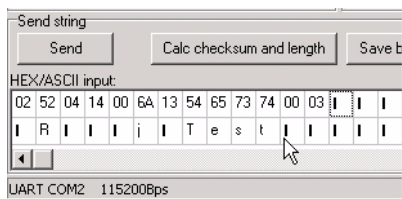

Figure 3-11. Change the String

Step 3: Change the string length field to "05". The value is calculated by the length of the word "Test" plus the end character "0x00". This value is still part of the payload and therefore is not updated by Step 4.

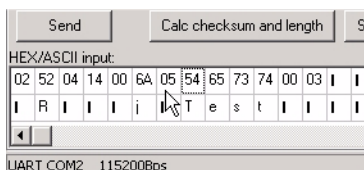

Figure 3-12. Change Payload Size

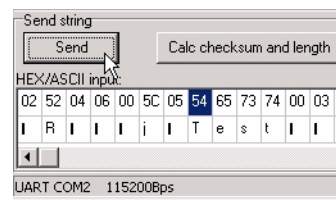

Figure 3-14. Send the Package to the LMX9820x

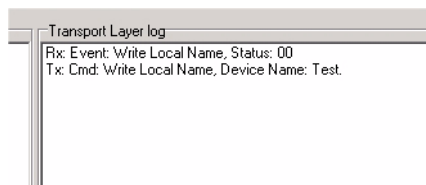

Figure 3-15. View Result within the Log Window

Step 6: In case the command is necessary in the future, the modified HEX string, which is still in the Command Line, can be saved by right clicking "Save bytes as commands".

Enter the name of the command that should be listed within the Command Directory.

The command will appear within the Command Directory.

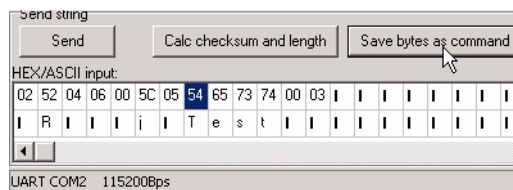

Figure 3-16. Save Bytes as Command

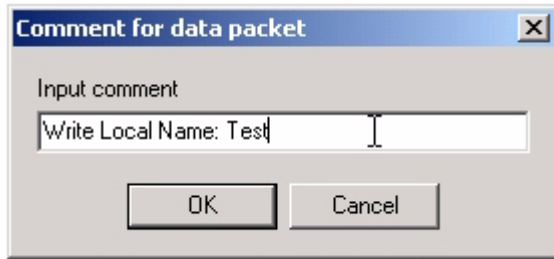

Figure 3-17. Enter the Command Name

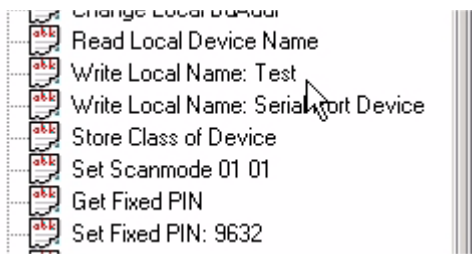

Figure 3-18. Entry Listed as New Command in Command Directory

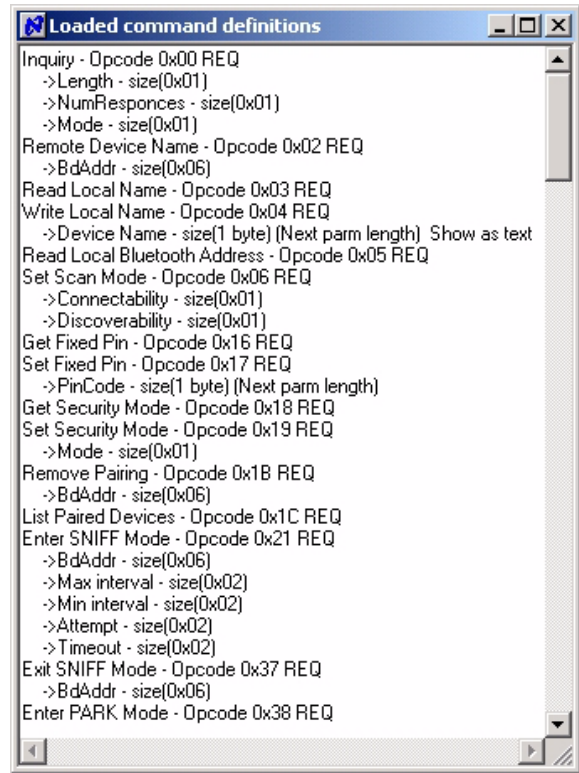

Figure 4-2. Command Definitions

4.0 Command Reference

The Simply Blue Commander supports all commands possible to send the LMX9820x. The commands have been defined with certain parameters and values. A full list of commands and events can be found in the menu by choosing "Definitions" (see Figure 4-1, Figure 4-2, and Figure 4-3). To get a full description of the commands refer to the *LMX9820x Bluetooth™ Serial Port Module: Designers Guide*.



Figure 4-1. Show Command Definitions

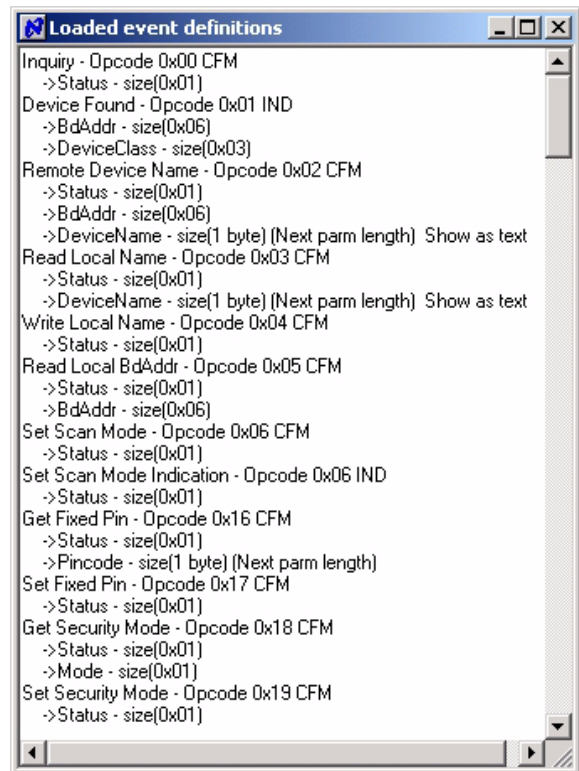

Figure 4-3. Event Definitions

LIFE SUPPORT POLICY

NATIONAL'S PRODUCTS ARE NOT AUTHORIZED FOR USE AS CRITICAL COMPONENTS IN LIFE SUPPORT DEVICES OR SYSTEMS WITHOUT THE EXPRESS WRITTEN APPROVAL OF THE PRESIDENT AND GENERAL COUNSEL OF NATIONAL SEMICONDUCTOR CORPORATION. As used herein:

1. Life support devices or systems are devices or systems which, (a) are intended for surgical implant into the body, or (b) support or sustain life, and whose failure to perform when properly used in accordance with instructions for use provided in the labeling, can be reasonably expected to result in a significant injury to the user.
2. A critical component is any component of a life support device or system whose failure to perform can be reasonably expected to cause the failure of the life support device or system, or to affect its safety or effectiveness.



National Semiconductor Corporation Americas
Email: new.feedback@nsc.com
Tel: 1-800-272-9959

National Semiconductor Europe
Fax: +49 (0) 180-530 85 86
Email: europe.support@nsc.com
Deutsch Tel: +49 (0) 69 9508 6208
English Tel: +44 (0) 870 24 0 2171
Français Tel: +33 (0) 1 41 91 87 90

National Semiconductor Asia Pacific Customer Response Group
Tel: +65-62544466
Fax: +65-62504466
Email: ap.support@nsc.com

National Semiconductor Japan Ltd.
Tel: 81-3-5639-7560
Fax: 81-3-5639-7507
Email: jpn.feedback@nsc.com

www.national.com