

Low Dose Rate Test Results of National Semiconductor's ELDRS-Free Bipolar Low Dropout (LDO) Regulator, LM2941 at Dose Rates of 1 and 10 mrad(Si)/s

Kirby Kruckmeyer, *Member, IEEE*, Larry McGee, Thang Trinh, and Joe Benedetto, PhD, *Senior Member, IEEE*

Abstract-- Low dose rate (LDR), ultralow dose rate (UDR) and high dose rate (HDR) total ionizing dose (TID) test results, drift analysis and an Enhanced Low Dose Rate Sensitivity (ELDRS) characterization are presented for National Semiconductor's EDLRS-free bipolar low dropout (LDO) regulator, LM2941WGRLQMLV (5962R9166702VYA). Dose rates used were 0.001, 0.01 and 170 rad(Si)/s.

I. INTRODUCTION

LOW dropout voltage regulators, often referred to as LDO regulators or simply LDOs, are commonly used in space applications for the regulated power supply to various components. Bipolar LDO regulators are of interest where a wide and relatively high input voltage range is required or where there is limited radiation and flight history data available for CMOS LDO regulators. Typical bipolar LDO regulators have an operating input voltage ranging from 16 V or higher down to less than 1 V above the output voltage. Many have been in use in space environments for over 20 years.

The bipolar LDO regulator, LM2941, was developed for automotive applications over 20 years ago but has found usage in space applications. It has an adjustable output range of 5 to 20 V, a dropout voltage of 0.8 V at full load, can support input voltages up to 26 V and output load currents up to 1 A and will survive input transients of -50 and +60 V (block diagram is shown in Fig. 1) [1].

Many bipolar LDO regulators have been shown to degrade when exposed to ionizing radiation. In addition, many bipolar LDO regulators experience Enhanced Low Dose Rate Sensitivity (ELDRS), where the product performance degrades more when exposed at a low dose rate (LDR),

similar to the dose rates seen in a space application, than when exposed at a high dose (HDR), for the same total ionizing dose (TID) [2]-[5]. Some versions of the LM2941 have been shown to fail LDR TID testing at doses from 18 to 25 krad(Si) [6][7].

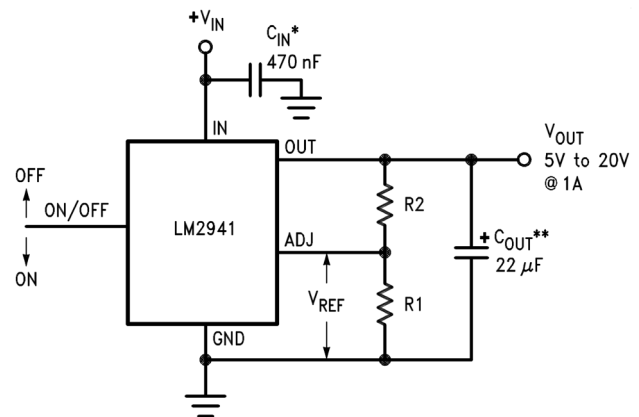

Fig. 1 Block diagram of the LM2941, 1 A Low Dropout Adjustable Regulator [1]

Historically, TID testing has been done under HDR conditions, typically between 50 and 300 rad(Si)/s, as outlined in MIL-STD-883, TM1019 [8]. Testing under LDR conditions was not routine, due to the time constraints. It can take several months to years to test products at the same dose rates of some applications. It had been proposed that it might be possible to simulate LDR response by irradiating products at elevated temperatures at HDR [9]. It was later found that this method was not valid for the LM2941 produced in National Semiconductor's Arlington, Texas wafer fabrication facility (fab) [6]. A new test method was then proposed using a dose rate of 10 mrad(Si)/s with a design margin of two for the parametric drift to qualify bipolar products for LDR environments [10]. This dose rate has been adopted for the LDR qualification in the latest revision of MIL-STD-883 (rev G) Test Method 1019 (rev. 7), released February 28, 2006 [8]. Also included in MIL-STD-883G, TM1019.7 is a characterization technique to determine if a product could be considered to have ELDRS.

Manuscript received July 29, 2009

Kirby Kruckmeyer is with National Semiconductor, Santa Clara, CA 95052 (telephone: 408-721-3548, email: kirby.kruckmeyer@nsc.com).

Larry McGee is with National Semiconductor, Santa Clara, CA 95052 (telephone: 408-721-7231, email: larry.mcgee@nsc.com).

Thang Trinh is with National Semiconductor, Santa Clara, CA 95052 (telephone: 408-721-2672, email: thang.trinh@nsc.com).

Joe Benedetto, PhD is with Radiation Assured Devices, Colorado Springs, Co 80919 (telephone: (719) 531-0800, email: jbenedetto@radiationassureddevices.com).

National Semiconductor has released a new version of the LM2941 that is produced in its Greenock, Scotland (UK) wafer fab using a unique wafer process flow. The National Semiconductor part number and the Defense Supply Center Columbus (DSCC) Standard Microcircuit Drawing (SMD) number are listed in Table I. This new version of the LM2941 has been put through the ELDRS characterization defined in MIL-STD-883G, TM1019.7. Per the test method, the product is qualified to 100 krad(Si) and could be considered to be “ELDRS-free” [8]. To verify the validity of this test method to qualify products for low dose rate applications using 10 mrad(Si)/s, units were also tested at an ultralow dose rate (UDR) of 1 mrad(Si)/s to 20 krad(Si).

TABLE I
PRODUCT AND LOT NUMBER TESTED

| National Part Number | DSCC SMD Number | Wafer Lot Number |
|-------------------------|--------------------|---------------------|
| LM2941WGRLQMLV | 5962R9166702VYA | JM06X44A |

II. TEST METHOD

The product tested is listed in Table I. These data only pertain to this particular product as other versions of the part have a different wafer process. All units tested were assembled in the 16 lead ceramic dual in line package (DIP) and burned-in according to the class V flow in MIL-PRF-38535 [11]. All LM2941 ceramic packages have a glass seal and no gold in the cavity.

An ELDRS characterization was done per MIL-STD-883, Test Method 1019.7, section 3.13.1.1. A four way split was run under LDR and HDR with units biased and unbiased during irradiation, as shown in Table II. Five samples per wafer from three different wafers were used in each experimental test leg. The three wafers came from the same wafer lot. In addition, testing was done under UDR as shown in Table II.

TABLE II
TEST MATRIX

| Dose Condition | Dose Rate | Bias Condition | Units |
|----------------|-------------------|----------------|-------|
| LDR | 10 mrad(Si)/s | Biased | 15 |
| LDR | 10 mrad(Si)/s | Unbiased | 15 |
| HDR | 169-188 rad(Si)/s | Biased | 15 |
| HDR | 169-188 rad(Si)/s | Unbiased | 15 |
| UDR | 1 mrad(Si)/s | Biased | 15 |
| UDR | 1 mrad(Si)/s | Unbiased | 15 |

The unbiased units had all leads tied to ground during irradiation. For the biased units, V_{in} was taken to 25.5 V through a 100 Ω resistor and V_{out} was connected to ground through a 1 k Ω resistor for a 5 mA load. A low output load was used to prevent high power dissipation and internal heating of the die that could lead to self annealing. V_{out} was set to 5 V, using a 3 and 1 k Ω divider on the Vadjust pin. The on/off pin was connected to ground (Fig. 1).

All irradiations were performed using a Cobalt-60 gamma ray source. HDR irradiation was performed at National Semiconductor’s radiation facility in Santa Clara, California.

LDR and UDR irradiation was done at Radiation Assured Devices (RAD) in Colorado Springs, Colorado. For the HDR legs testing was done at 0, 3, 10, 30, 50 and 100 krad(Si) TID levels. The LDR legs were pulled at close to the same levels, but not always exactly at those levels. The UDR legs were pulled and tested at the same time as the LDR legs, so the TID level for UDR legs was one tenth that of the LDR legs. The LDR legs were taken to 102 krad(Si). The UDR legs continued processing to 13 and 20 krad(Si).

Electrical testing was done with an Eagle ETS500 test system at National Semiconductor’s Santa Clara radiation facility. The same tester and test board were used at all test points. All datasheet and SMD parameters were tested. For the HDR legs, electrical testing was completed within an hour of being removed from the gamma radiation. The LDR and UDR legs were shipped overnight from the test facility at RAD to National for testing, and shipped back overnight to RAD to resume irradiation.

III. LDR (10 MRAD/S) RESULTS

All units passed TID testing at all radiation levels tested with all parameters inside the pre irradiation limits listed in the datasheet and SMD.

A. ELDRS Characterization

The ELDRS characterization results are summarized in Table III. For each parametric test, the median parametric drift from 0 rad to 100 krad(Si) was calculated for the 15 units in each LDR and HDR leg. Some parameters, such as V_{out} are tested under a number of different conditions. The results shown in Table III are for the conditions that resulted in the worst case parametric drift. The last two columns in Table III indicate if any of the LDR test results were outside the pre irradiation spec and SMD limits. Per MIL-STD-883G, Test Method 1019.7, section 3.13.1.1, if, for any parameters, the ratio of the median LDR drift to the median HDR drift is greater than 1.5 and the parametric reading is outside the pre irradiation test limits, the “part is considered to be ELDRS susceptible”. Since all parametric readings at all radiation levels were inside the pre irradiation spec limits, the part does not meet the definition of being ELDRS susceptible.

B. LDR and HDR 100 krad(Si) Results

Table IV lists the average parametric readings at 0 rad for the 15 units from the LDR biased leg, along with the average parametric drift and the standard deviation (sigma) of the parametric drift through 100 krad(Si) for the 15 units in each of the LDR and HDR test legs. The parametric specification range and test system guardband for each parameter are shown in Table V. The average parametric readings for the HDR and LDR legs at each of the radiation test points are plotted in Figs. 2 to 7.

TABLE III
ELDRS CHARACTERIZATION RESULTS

| Parameter | Conditions | | Median drift through 100 krad(Si) | | | | LDR/HDR | | Any LDR results outside spec limits? | |
|--------------------|--|-------|-----------------------------------|----------|--------|----------|-------------|----------|--------------------------------------|----------|
| | Vin=10V, Vout=5V, Iout=5mA unless otherwise indicated | Units | LDR | | HDR | | Drift Ratio | | Biased | Unbiased |
| | | | Biased | Unbiased | Biased | Unbiased | Biased | Unbiased | | |
| Output Voltage | | V | 0.0118 | -0.0088 | 0.0162 | -0.0084 | 0.73 | 1.05 | No | No |
| Dropout Voltage | Iout=1A, Vout=20V | V | 0.070 | 0.060 | 0.050 | 0.053 | 1.40 | 1.13 | No | No |
| Line Regulation | Vin=7-26V | mV | 0.31 | 0.44 | 0.44 | 0.64 | 0.69 | 0.68 | No | No |
| Load Regulation | Vin=25V, Iout=50mA-1A | mV | -2.48 | -2.68 | -1.26 | -1.63 | 1.97 | 1.65 | No | No |
| Adjust Pin Voltage | | V | 0.0027 | -0.0026 | 0.0040 | -0.0025 | 0.67 | 1.04 | No | No |
| Quiescent Current | Iout=1A | mA | 1.99 | 1.15 | 1.48 | 1.03 | 1.35 | 1.12 | No | No |
| On/Off Pin Current | Von/off=2V, output off | μA | -3.18 | -2.08 | -2.98 | -1.90 | 1.07 | 1.09 | No | No |
| Ripple Rejection | Vin=25V, Iout=100mA Fout=120Hz, 1 Vrms, | dB | -0.5 | -0.5 | -0.8 | -0.9 | 0.62 | 0.56 | No | No |

TABLE IV
AVERAGE READING AT 0 KRAD AND AVERAGE (AVE.) AND STANDARD DEVIATION (SIGMA) OF THE PARAMETRIC DRIFT THROUGH 100 KRAD

| Parameter | Conditions | | 0 Rad Ave. Value | LDR Drift | | | | HDR Drift | | | |
|--------------------|--|-------|------------------------|-----------|--------|----------|--------|-----------|--------|----------|--------|
| | Vin=10V, Vout=5V, Iout=5mA unless otherwise indicated | Units | | Biased | | Unbiased | | Biased | | Unbiased | |
| | | | | Ave. | Sigma | Ave. | Sigma | Ave. | Sigma | Ave. | Sigma |
| Output Voltage | | V | 5.0076 | 0.0114 | 0.0031 | -0.0089 | 0.0015 | 0.0167 | 0.0041 | -0.0085 | 0.0015 |
| Dropout Voltage | Iout=1A, Vout=20V | V | 0.515 | 0.077 | 0.017 | 0.054 | 0.022 | 0.043 | 0.023 | 0.049 | 0.027 |
| Line Regulation | Vin=7-26V | mV | -1.18 | 0.35 | 0.21 | 0.43 | 0.33 | 0.45 | 0.21 | 0.63 | 0.36 |
| Load Regulation | Iout=50mA-1A | mV | -10.47 | -2.65 | 0.52 | -2.99 | 0.96 | -1.25 | 0.78 | -1.53 | 0.72 |
| Adjust Pin Voltage | | V | 1.2754 | 0.0026 | 0.0008 | -0.0026 | 0.0003 | 0.0040 | 0.0011 | -0.0025 | 0.0004 |
| Quiescent Current | Iout=1A | mA | 24.16 | 1.97 | 0.13 | 1.14 | 0.09 | 1.48 | 0.17 | 1.03 | 0.11 |
| On/Off Pin Current | Von/off=2V, output off | μA | 45.50 | -3.16 | 0.69 | -2.15 | 0.59 | -3.14 | 0.47 | -1.88 | 0.31 |
| Ripple Rejection | Vin=25V, Iout=100mA Fout=120Hz, 1 Vrms | dB | 65.1 | -0.5 | 0.24 | -0.5 | 0.18 | -0.9 | 0.24 | -0.8 | 0.26 |

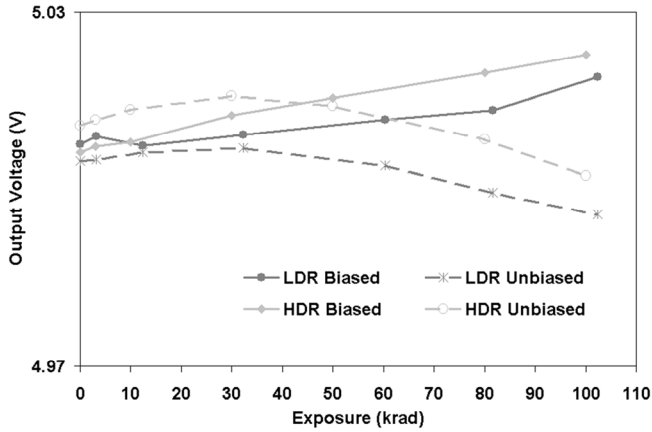

Fig. 2 Output Voltage vs. radiation exposure. Test conditions are listed in Table IV. Specification limits for this parameter are 4.85 to 5.15 V.

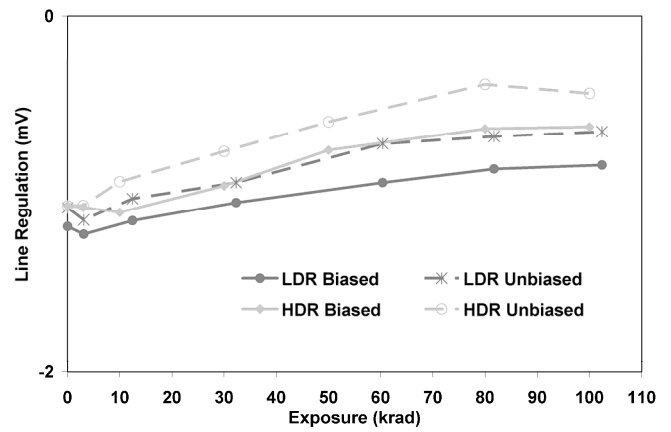

Fig. 4 Line Regulation vs. radiation exposure. Test conditions are listed in Table IV. Specification limits for this parameter are -50 to +50 mV.

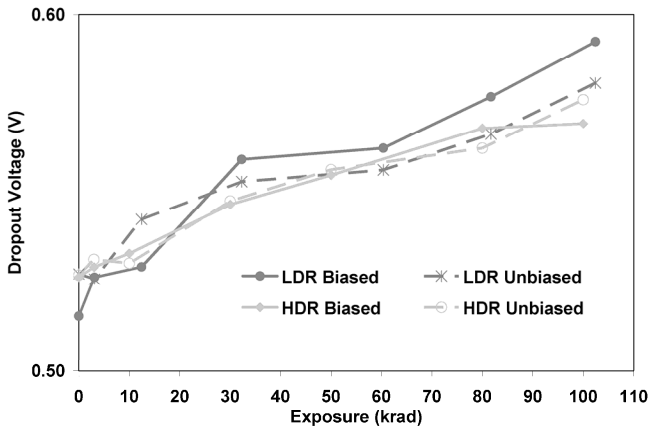

Fig. 3 Dropout Voltage vs. radiation exposure. Test conditions are listed in Table IV. Upper specification limit for this parameter is 0.8 V.

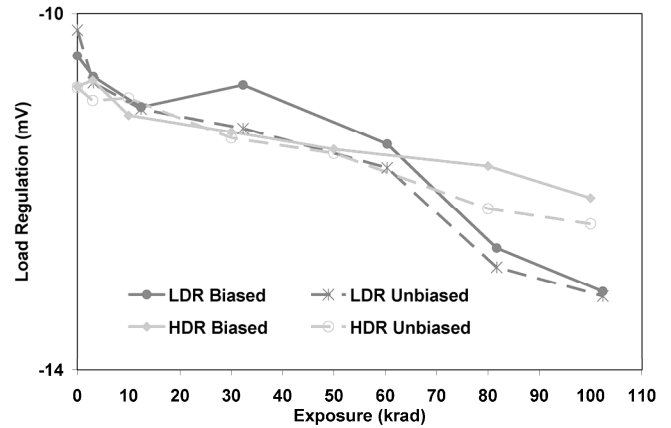

Fig. 5 Load Regulation vs. radiation exposure. Test conditions are listed in Table IV. Specification limits for this parameter are -50 to +50 mV.

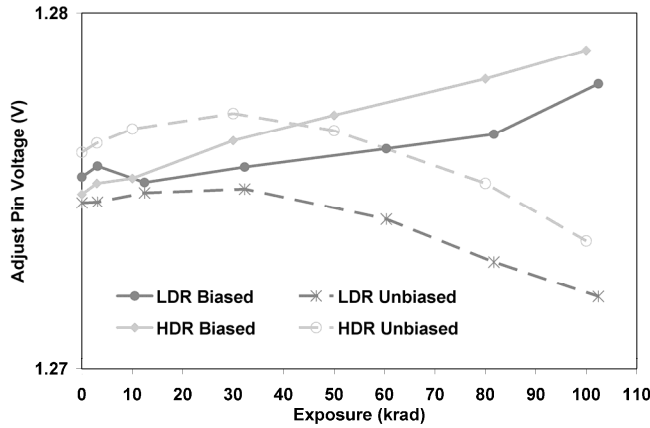

Fig. 6 Adjust Pin Output vs. radiation exposure. Test conditions are listed in Table IV. Specification limits for this parameter are 1.237 to 1.313 V.

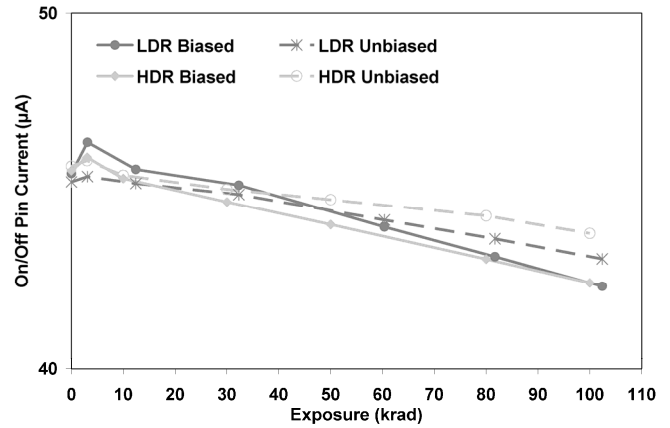

Fig. 8 On/Off Pin Current vs. radiation exposure. Test conditions are listed in Table IV. Maximum specification limit for this parameter is 100 µA.

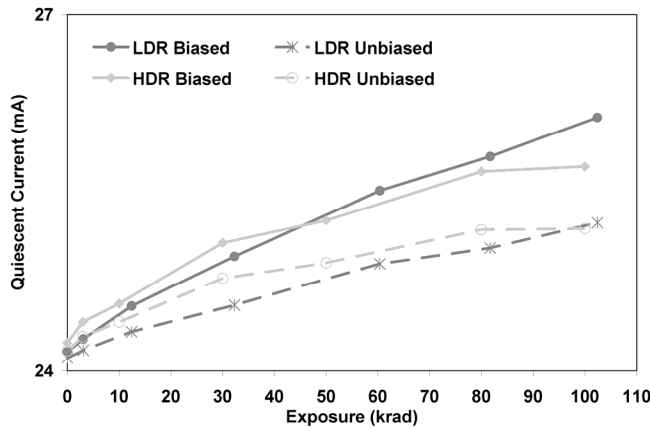

Fig. 7 Quiescent Current vs. radiation exposure. Test conditions are listed in Table IV. Maximum specification limit for this parameter is 45 mA.

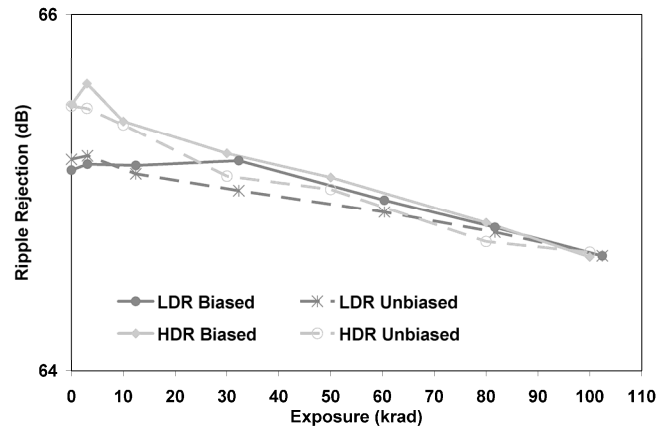

Fig. 9 Ripple Rejection vs. radiation exposure. Test conditions are listed in Table IV. Minimum specification limit for this parameter is 48 dB.

IV. UDR (1 MRAD/S) RESULTS

The average parametric drift through 13.0 krad(Si) for the UDR test legs, 12.4 krad(Si) for the LDR test legs and 10.0 krad(Si) for the HDR test legs are summarized in Table V. The 10 to 13 krad(Si) TID range was chosen because this was the highest TID tested and tightest TID range where there were data for all three dose rates.

The final two columns of Table V list the specification range for each parametric test and the electrical test system

guardbands. The guardbands incorporate all sources of the test system variability: test system repeatability and tester to tester, test board to test board and setup to setup correlation variations.

The average parametric readings through 20.0 krad(Si) for the UDR test legs, 32.3 krad(Si) for the LDR test legs and 30.0 for the HDR test legs are plotted in Figs. 10 to 17.

TABLE V
AVERAGE PARAMETRIC DRIFT FOR UDR (0.001 RAD/S), LDR (0.01 RAD/S) AND HDR (169-188 RAD/S) TEST LEGS

| Parameter | Conditions Vin=10V, Vout=5V, Iout=5mA unless otherwise indicated | Units | UDR | | LDR | | HDR | | Spec Range | Test Guard Band |
|--------------------|--|-------|---------------|----------|---------|----------|--------|----------|---------------|-----------------------|
| | | | 13.0 krad(Si) | Unbiased | Biased | Unbiased | Biased | Unbiased | | |
| Output Voltage | | V | -0.0023 | -0.0029 | -0.0003 | 0.0015 | 0.0017 | 0.0028 | 0.3 | 0.0170 |
| Dropout Voltage | Iout=1A, Vout=20V | V | -0.009 | 0.004 | 0.014 | 0.015 | 0.007 | 0.003 | 0.8 | 0.100 |
| Line Regulation | Vin=7-26V | mV | -0.19 | 0.01 | 0.03 | 0.05 | -0.04 | 0.14 | 100 | 2.00 |
| Load Regulation | Iout=50mA-1A | mV | -1.18 | -0.82 | -0.58 | -0.89 | -0.32 | -0.12 | 100 | 3.60 |
| Adjust Pin Voltage | | V | -0.0005 | 0.0001 | -0.0002 | 0.0003 | 0.0005 | 0.0007 | 0.076 | 0.0020 |
| Quiescent Current | Iout=1A | mA | 0.41 | 0.22 | 0.38 | 0.22 | 0.33 | 0.24 | 45 | 2.70 |
| On/Off Pin Current | Von/off=2V, output off | µA | -0.65 | -0.75 | 0.11 | -0.04 | -0.22 | -0.25 | 100 | 11.60 |
| Ripple Rejection | Vin=25V, Iout=100mA Fout=120Hz, 1 Vrms, | dB | -0.2 | 0.3 | 0.0 | -0.1 | -0.1 | -0.1 | | 5.4 |

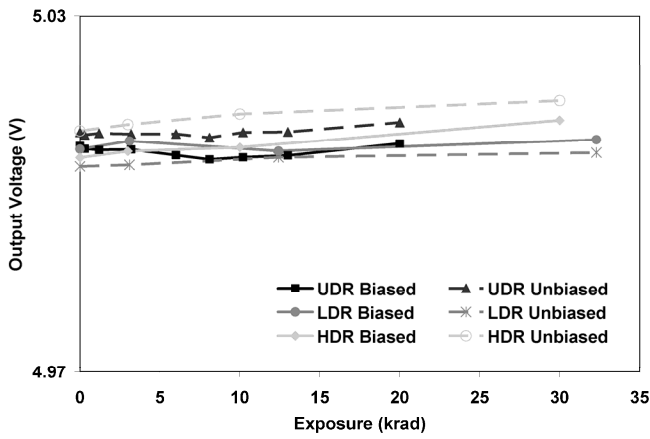

Fig. 10 Output Voltage vs. radiation exposure. Test conditions are listed in Table V. Specification limits for this parameter are 4.85 to 5.15 V.

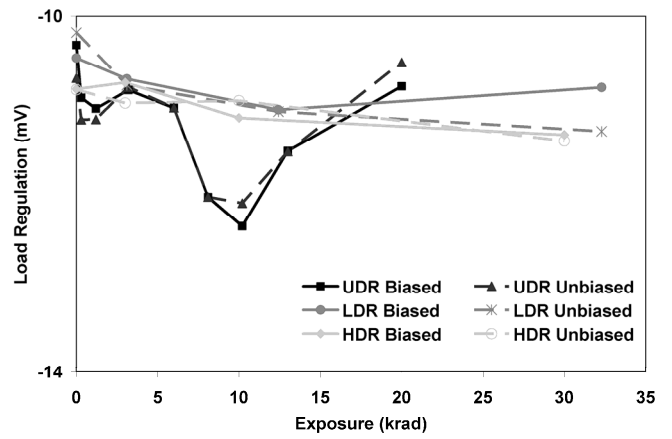

Fig. 13 Load Regulation vs. radiation exposure. Test conditions are listed in Table V. Specification limits for this parameter are -50 to +50 mV.

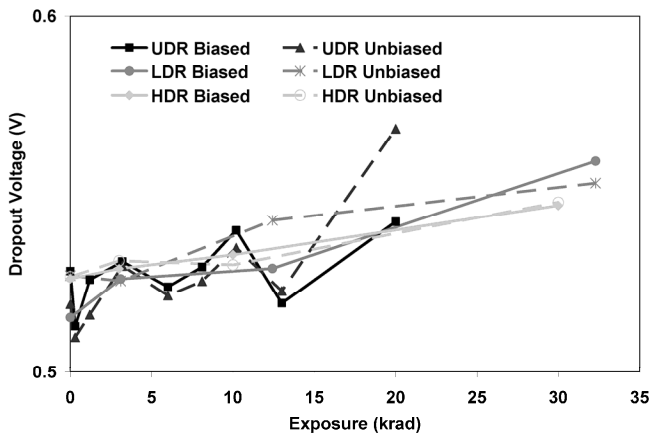

Fig. 11 Dropout Voltage vs. radiation exposure. Test conditions are listed in Table V. Maximum specification limit for this parameter is 0.8 V.

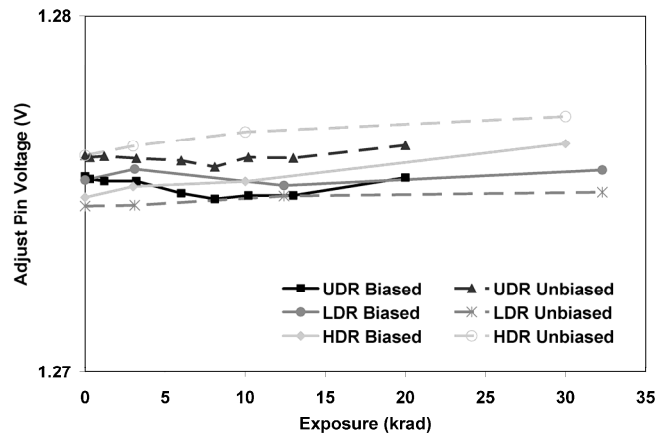

Fig. 14 Adjust Pin Voltage vs. radiation exposure. Test conditions are listed in Table V. Specification limits for this parameter are 1.237 to 1.313 V.

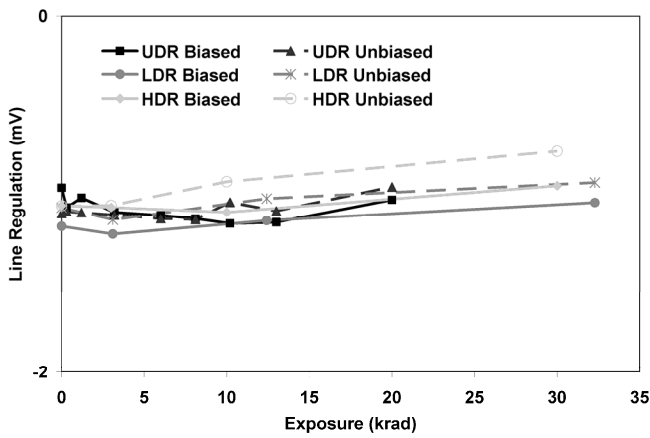

Fig. 12 Line Regulation vs. radiation exposure. Test conditions are listed in Table V. Specification limits for this parameter are -50 to +50 mV.

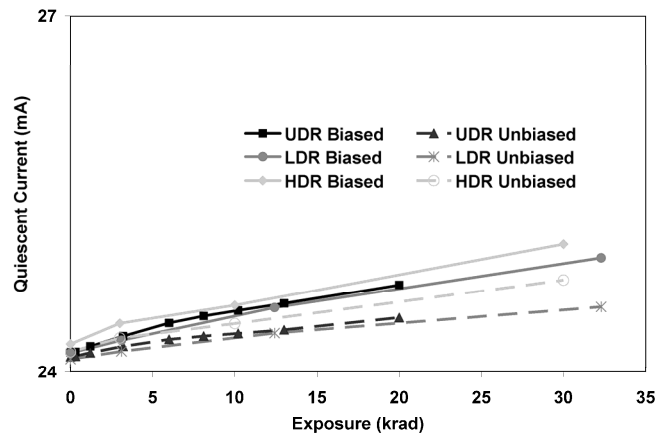

Fig. 15 Quiescent Current vs. radiation exposure. Test conditions are listed in Table V. Maximum specification limit for this parameter is 45 mA.

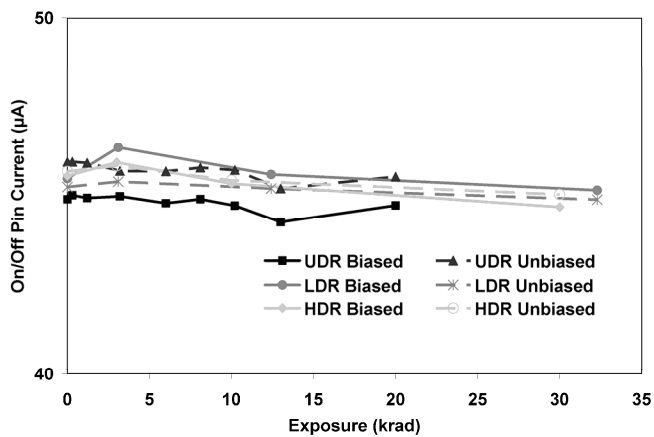

Fig. 16 On/Off Pin Current vs. radiation exposure. Test conditions are listed in Table V. Maximum specification limit for this parameter is 100 μA .

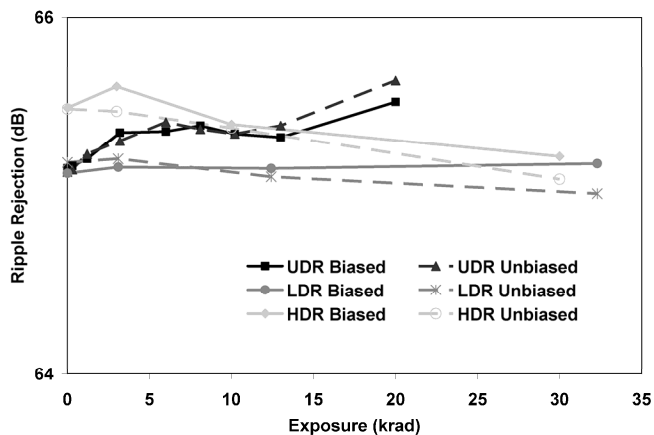

Fig. 17 Ripple Rejection vs. radiation exposure. Test conditions are listed in Table V. Minimum specification limit for this parameter is 48 dB.

V. DISCUSSION

Table V lists the electrical test system guardbands which incorporate all of the sources of variability that can affect the repeatability of the electrical test system. Since all electrical testing was done using the same electrical tester and test board, two sources of repeatability error were eliminated. The HDR test legs were irradiated and tested in one session, also eliminating time based and setup repeatability errors. The LDR and UDR test points were spread out over several days to several weeks, making those test legs susceptible to setup repeatability errors. Any differences in data greater than the test system guardband can be considered significant and not within the experimental error.

In all cases, the difference in parametric drift between the UDR (1 mrad/s) and LDR (10 mrad/s) test legs is small and a fraction of the electrical test system guardband.

Fig. 10 to 17 indicate that the UDR, LDR and HDR parametric drifts follow the same general trends with a few exceptions. For some of the parameters (Fig. 11 and 17) the UDR results may be indicating the start of a steeper upward trend between 13 and 20 krad(Si). Since there is no data at 20 krad(Si) for the LDR and HDR test legs, it is not possible to tell if this trend is unique to the UDR. The 100 krad(Si) plots (Fig. 3 and 9) indicate that the LDR test legs may have

had a similar phenomena somewhere in the region of 10 to 30 krad(Si) before settling back to a trend that matched that of the HDR test legs.

VI. CONCLUSIONS

The ELDRS characterization, described in Test Method 1019 of MIL-STD-883 was demonstrated on National Semiconductor's bipolar low dropout (LDO) regulator, LM2941WGRQLMLV (5962R9166702VYA). The product was found not to be ELDRS sensitive to 100 krad(Si) per the definition in the test method.

The validity of the ELDRS characterization for this part was demonstrated to 20 krad(Si) by also testing material at a dose rate (1 mrad/s) lower than that required by the test method (10 mrad/s). Testing a part at 1 mrad/s to 20 krad requires that the part be irradiated for 232 days. The total test time is even longer due to the time required for shipping and performing electrical parametric test at the interim test points. Data for the 30 krad(Si) test point will be available in December, 2009.

VII. REFERENCES

- [1] "LM2941 - 1 A Low Dropout Adjustable Regulator", National Semiconductor, <http://www.national.com/mpf/LM/LM2941.html>
- [2] S. S. McClure, J. L. Gorelick, C. C. Yui, B. G. Rax, M. C. Wiedeman, "Continuing evaluation of bipolar linear devices for total dose bias dependency and ELDRS effects", 2003 IEEE Radiation Effects Data Workshop Record, pp. 1-5
- [3] S. S. McClure, J. L. Gorelick, R. Pease, A. H. Johnston, "Dose rate and bias dependency of total dose sensitivity of low dropout regulators", 2000 IEEE Radiation Effects Data Workshop Record, pp. 100-105
- [4] R. L. Pease, G. W. Dnuham, J. E. Seiler, "Total dose and dose rate response of low dropout regulators", 2006 IEEE Radiation Effects Data Workshop Record, pp. 85-93
- [5] R. L. Pease, S. S. McClure, J. Gorelick, S. C. Witczak, "Enhanced low-dose-rate sensitivity of a low-dropout regulator", *IEEE Trans. Nucl. Sci.*, vol. 51, no. 6, pp. 2571-2576, Dec. 1998
- [6] W. Abere, F. Brueggeman, R. Pease, J. Krieg, M. Simons, "Comparative analysis of low dose-rate accelerated, and standard cobalt-60 for a low-dropout voltage regulator and voltage reference", 2000 IEEE Radiation Effects Data Workshop Record, pp. 177-180
- [7] R. M. Chavez, B. G. Rax, L. Z. Scheick, A. H. Johnston, "Total ionizing dose effects in bipolar and CMOS devices", 2005 IEEE Radiation Effect Data Workshop Record, pp. 144-148
- [8] MIL-STD-883 Test Method Standard, Microcircuits, Department of Defense, Defense Supply Center Columbus, Columbus, OH, June 18, 2004 <http://www.dsc.dla.mil/Downloads/MilSpec/Docs/MIL-STD-883/std883.pdf>.
- [9] R. L. Pease, L. M. Cohn, D. M. Fleetwood, M. A. Gehlhasusen, T. L. Turflinger, D. B. Brown, A. H. Johnston, "A proposed hardness assurance test methodology for bipolar linear circuits and devices in a space ionizing radiation environment", *IEEE Trans. Nucl. Sci.*, vol. 44, no. 6, Dec. 1997, pp. 1981-1988
- [10] R. L. Pease, M. Gehlhasusen, J. Krieg, J. Titus, T. Turflinger, D. Emily, L. Cohn, "Evaluation of proposed hardness assurance for bipolar linear circuits with enhanced low dose rate sensitivity", *IEEE Trans. Nucl. Sci.*, vol. 45, no. 6 Dec. 1998, pp. 2665-2672
- [11] "Standard Microcircuit Drawing 5962-00501", Defense Supply Center Columbus, Oct. 10, 2009, <http://www.dsc.dla.mil/Downloads/MilSpec/Smd/00501.pdf>