

# Testing Applications in Uncompressed HDTV Signals

James R. Waschura  
SyntheSys Research, Inc.  
Menlo Park, California U.S.A.

## Abstract

This paper focuses on testing methods and applications for the uncompressed HDTV signal, SMPTE 292M. It includes a description of the signal's electrical characteristics, digital format, and special protocols for embedding auxiliary information. This is followed by an explanation of testing methodologies and tools used to verify compliance to the SMPTE specification. Afterwards, the author suggests two specific areas for automatic testing in the product manufacturing cycle: design verification and manufacturing test.

## Introduction

The SMPTE 292M specification defines a serial waveform, electrical interface, and bit stream for the transport of various high definition television signals<sup>1</sup>.

These signals are used to transmit uncompressed high definition television between video equipment such as cameras, video tape recorders, disk recorders, routers, effects workstations, switchers, monitors, and test and evaluation systems. Presently, the most popularly supported forms of digital high definition television, 720-P and 1080-I, are both carried over the SMPTE 292M transport. Manufacturers and broadcasters are eager to move forward with high definition television system implementations now that a reliable standard has emerged, and off-the-shelf components are becoming available to support this important application.

Over time, many standards come and go, while some become the bedrock for industry-wide progress. For standard definition television signals, the SMPTE 259M signal has obviously provided this type of foundation. For the upcoming wave of industry progress, the SMPTE 292M signal is the next link in the evolutionary chain of technology that will provide the digital infrastructure for high definition television. It will also quickly be adopted to carry many forms of standard definition signals, both interlaced and progressive, and therefore will provide users with desired flexibility in application.

The SMPTE 292M standard defines serial streams that are communicated via 75 Ohm copper coaxial cable or optical fiber. Multiple source formats are defined in separate SMPTE documents (Figure 1) that specify the scanning geometry and the mapping of pixels onto an abstract 20-bit word stream consisting of 10-bit luminance and multiplexed chrominance samples. The SMPTE 292M document specifies how the word streams are subsequently augmented with line numbers and cyclical redundancy codes, and then prepared and serialized for transmission.

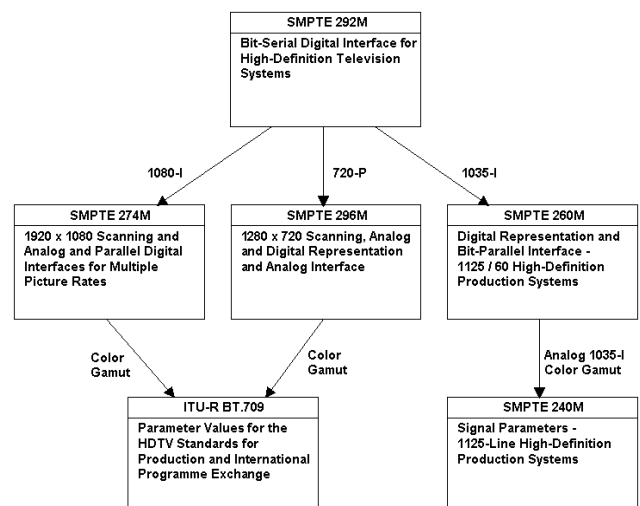

Figure 1 - Standards Hierarchy

On the level of the serial waveform, SMPTE 292M signals are very similar to existing SMPTE 259M signals (besides the obvious data rate difference). They reference the same electrical characteristics (although the rise/fall times are appropriately faster). They are communicated over the same physical cables. They have the same randomizing polynomial and channel code, and they follow the same basic structure utilizing timing reference signal (TRS) values to accomplish framing.

While many features are common between SMPTE 259M and SMPTE 292M signals, the SMPTE 292M signal operates at 5.5 times the data rate, and therefore has more limited capability for long distance transmission, and is more susceptible to transmission errors including signal attenuation, reflections from impedance mismatches, and jitter.

There are a number of challenges in store for developers implementing SMPTE 292M systems today, including:

- a.) Inherent electrical difficulties in designing systems to run 5.5 times faster than previous systems;
- b.) Early stage of off-the-shelf components to implement the serial interfaces;
- c.) Subtle differences between standard definition systems that are well understood and new high definition systems;
- d.) Requirements for higher speed general purpose test equipment, like oscilloscopes, logic analyzers, and time domain reflectometers;
- e.) Need for application-specific tools for testing compliance to SMPTE specifications.

Yet, there is significant reward, so the combined community of developers is working with IC manufacturers and test equipment makers to create the building blocks and the tools that will become the new “bedrock;” and once again, the next wave of industry progress is upon us.

## Electrical Characteristics

The SMPTE 292M standard defines a bit-serial digital coaxial and fiber optic interface for HDTV component signals operating at data rates of 1.485 Gbit/sec and 1.485/1.001 Gbit/sec. The 1.485/1.001 Gbit/sec rate accommodates NTSC facilities operating at 30/1.001 (29.97) Hz frame rates. This paper will concentrate chiefly on the coaxial specifications, as they are most prominent at this time. This paper will also focus on non-NTSC timing; that is, frame rates and data rates that are not adjusted by the 1.001 divisor. These differences are relatively unimportant for the testing applications discussed in this paper.

## Serial Waveform

The coaxial specifications for the 1.485 Gbit/sec signals are listed in Figure 2. These specifications identify basic performance measurements for the electrical interface.

Measurement	Specification
Serial Data Rate	1.485 Gb/s
Unit Interval	673 picoseconds
Impedance	75 ohms
Return-loss	15 dB from 5 MHz to 1.485 GHz (at least)
Amplitude	800 millivolts, +/- 10%
DC Offset	0.0 volts, +/- 500 millivolts
Rise/Fall times	270 nanoseconds (not less than)
- measured at 20% and 80% levels	within 100 ps of eachother
Overshoot	10% of amplitude (not to exceed)
Amplitude excursions	50 millivolts (not to exceed)
- from pathological signals	
Jitter	
- above 10 Hz (timing)	1 unit interval (673 picoseconds), p-p
- above 1 KHz (alignment)	20% unit interval (134.6 picoseconds), p-p

Figure 2 – Coaxial Specifications

## Parallel-to-Serial Conversion

The serial bit stream is converted from the abstract 20-bit parallel words of the source format signal as shown in Figure 3. This process involves randomization, NRZ-I encoding, and parallel-to-serial conversion.

Randomization is used to ensure that the communicated bit stream has minimum DC content. This ensures the existence of many bit transitions that are helpful in phase locked loop (PLL)-based clock recovery. Unfortunately, randomizing circuits produce error multiplication, since an error gets fed back into the feedback shift registers, but this consequence is unimportant relative to the requirement for having many transitions available for clock recovery. The randomizing polynomial is  $G(X) = X^9 + X^4 + 1$ .

The NRZ-I (non-return to zero inverted) encoding cuts the transition frequency roughly in half, and provides polarity independence to the received signal. Subsequently, the serial bit stream is driven onto the copper wire.

The channel coding, including randomization and NRZ-I encoding are identical to SMPTE 259M<sup>2</sup>.

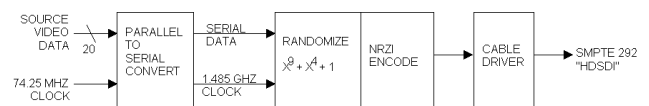
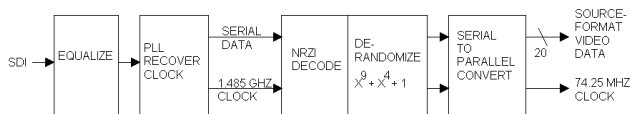

Figure 3 - Serialization

## Serial-to-Parallel Conversion

SMPTE 292M receivers first equalize the received signal to minimize cable-induced signal distortions, and then perform deserialization; decoding the serial bit stream back into multiplexed luminance and chrominance samples of the original source format (see Figure 4).



**Figure 4 – Deserialization**

During cable transmission, the serial waveforms are subject to many distortions from cable-related attenuation and impedance mismatches. Long lengths of cable act like an equalizer, attenuating the signal as a function of frequency. SMPTE 292M receiver designs pre-equalize the received signal to accommodate for these distortions. Equalizers attempt to return the signal back to its correct 800 mV p-p levels. Equalizers often expect that the transmitted signal was the correct 800 mV p-p level, and gauge the amount of equalization required by the amplitude of the received signal. For this reason, boosting the level of the signal before it is transmitted, or after it is received but before it enters the equalizer, is not recommended.

### Jitter

With a properly functioning equalizer appropriately reshaping the received waveform’s signal level, the largest source of digital error comes when individual bits are misdetected because they are clocked at the wrong point in time. This situation occurs when there is phase difference between the input signal and the serial clock recovered from the input signal using a PLL design. The peak-to-peak amount of phase difference between the recovered clock and the input signal is termed “alignment jitter.” This peak-to-peak measurement integrates all frequencies of jitter from the tracking bandwidth of the PLL upwards.<sup>3</sup>

### Distortion

Many signal distortions are caused by impedance mismatches along the transmission path. Each time this occurs, reflections occur that distort the waveform. At high frequencies, very minor impedance mismatches can cause error-inducing distortions. These include:

- f.) Cable impedance discontinuities
- g.) Cable-to-Connector connections
- h.) Connector-to-Connector connections, including oxidation
- i.) Connector-to-Printed Circuit Board (PCB) trace connections. Different types of connectors preserve impedance better than others.
- j.) PCB trace geometry – for instance, right-angle turns mean impedance discontinuities
- k.) Component accuracy – especially resistors and capacitors

Distortions tend to make the equalizer’s job more difficult, and combined with jitter, are the most difficult

aspects of designing communications systems with 1.485 Gbit/sec data rates.

## Digital Format

The SMPTE 292M signal transports multiple source formats at multiple frame rates. This paper will not make a distinction between 30 Hz / 60 Hz frame rates and 29.97 Hz / 59.94 Hz. This difference exists to accommodate otherwise-NTSC plants. The effect of these slight differences in frame rates is a slight change in the serial clocking rate from 1.485 Gbit/sec to 1.4835 Gbit/sec. These differences do not affect the structure of the digital format in question.

This paper will focus on 1035-I/30, 1080-I/30, and 720-P/60 as shown in Figure 5, since these are presently the most implemented systems. Other source formats that will be important include progressive 24-Hz frame rate (for film applications), and both interlaced and progressive 25-Hz frame rates for Australia, and eventually Europe.

Reference SMPTE standard	260M			295M			274M						296M	
Format	A	B	C	D	E	F	G	H	I	J	K	L	M	
Lines per frame	1125	1125	1250	1125	1125	1125	1125	1125	1125	1125	1125	750	750	
Words per active line	1920	1920	1920	1920	1920	1920	1920	1920	1920	1920	1920	1200	1200	
Total active lines	1035	1035	1080	1080	1080	1080	1080	1080	1080	1080	1080	720	720	
Words per total line	2200	2200	2376	2200	2200	2640	2200	2200	2640	2750	2750	1660	1660	
Frame Rate (Hz)	30	29.97	25	30	29.97	25	30	29.97	25	24	23.976	60	59.94	
Field per frame	2	2	2	2	2	2	1	1	1	1	1	1	1	
Data rate (Gb/s)	1.485	1.4835	1.485	1.485	1.4835	1.485	1.485	1.4835	1.485	1.485	1.4835	1.485	1.4835	
	1035I/30			1080I/30						720P/60				

**Figure 5 – Source Formats<sup>4</sup>**

As shown in Figure 5, 25-Hz and 24-Hz, as well as progressive source formats, are transmitted using the same 1.485 Gbit/sec (or 1.4835 Hz) data rate by adjusting the number of full frame lines and words, while maintaining the appropriate number of active area lines and words.

### TRS Framing

SMPTE 292M signals in the 20-bit parallel domain actually comprise two separate 10-bit channels operating side-by-side; one for luminance, and one for multiplexed chrominance. Each channel possesses its own framing information to distinguish the location of ancillary data and active picture data within the lines. One timing reference signal (TRS) at the beginning of the active picture area is referred to as the SAV (start active video), and a second at the end of the active picture area is referred to as the EAV (end active video). Both the EAV/SAV are prefaced by a series of synchronization values that are not permitted anywhere else in the word stream, making them easy to identify. At the beginning of each line, additional information is provided indicating the line number and a cyclic redundancy code (CRC) that is used to detect errors in the previous active line.

LINE INFORMATION		
LUM(Y)	CHR(C)	INFO
3FF	3FF	EAV
000	000	
000	000	
XYZ	XYZ	
LIN	LIN	LINE
LIN1	LIN1	NUMBER
CRC0	CRC0	LINE
CRC1	CRC1	CRC
HANC	HANC	HORIZ.
HANC	HANC	ANCILLARY
...	...	DATA
HANC	HANC	
HANC	HANC	
3FF	3FF	SAV
000	000	
000	000	
XYZ	XYZ	
AP	AP	ACTIVE
AP	AP	PICTURE
...	...	DATA

Figure 6 – Line Information

Therefore, each line of each channel begins with an EAV consisting of a preamble 3FF 000 000 synchronization sequence indicating the presence of the EAV. The next word is referred to as an XYZ word, and it contains encoded F-bit, V-bit, H-bit information, together with error protection bits. The F-bit indicates video field timing. The V-bit indicates vertical active and inactive lines. The H-bit indicates horizontal active and inactive pixels. The protection bits enable correction of one error occurring within the XYZ word. Unfortunately, due to error multiplication caused by randomizing circuits in the SMPTE 292M specification, multiple bit errors are more common than single bit errors. This reduces the usefulness of this feature for SMPTE 292M-transported source format signals.

XYZ VALUES CONTAINED WITHIN TRS CODES (EAV / SAV)

9 (MSB)	8	7	6	5	4	3	2	1	0 (LSB)
1	F	V	H	P3	P2	P1	P0	0	0

F=0 during field 1; F=1 during field 2  
V=1 during field blanking; F=0 elsewhere  
H=0 in SAV; H=1 in EAV  
P0,P1,P2,P3=protection bits based on value of F,V,H

Figure 7 – XYZ Values Contained within TRS Codes

Next, two ten-bit words are used to indicate the video line number, ranging from 1 to 1125 (or 750 in the case of 720-P systems).

After this, two ten-bit words are used to communicate a cyclic redundancy code (CRC) computed on the previous line. The CRC polynomial is  $CRC(X) = X^{18} + X^5 + X^4 + 1$ . The calculation starts at the first active word and ends at the final word of the line number. Therefore, it does not identify errors in the horizontal ancillary data space.

### Source Format Mappings

Each source format defines a unique mapping of active picture area and ancillary data space onto the abstract word space of the underlying SMPTE 292M transport layer. The mappings for the three major source formats described in this paper are shown in Figure 8. Notice that 1080-I and 720-P have square pixels with respect to a 16:9 display aspect ratio. 1035-I does not.

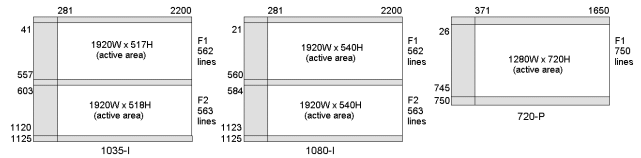

Figure 8 – Source Format Mappings

The active area contains pixel information that is directly mapped onto the source format image. The horizontal ancillary data space is commonly used to embed auxiliary information, including digital audio. The vertical ancillary data space may also be used to contain embedded packets of auxiliary information, such as time code and teletext.

Work continues on creating additional mappings of standard definition source formats onto the SMPTE 292M signal. These will probably include 480I/30, 480P/30, and 480P/60.

### Data Range

Within the active picture area and the ancillary data space, certain values within the possible range of 10-bit values are reserved for synchronization purposes, as shown previously. These reserved codes range from 0 to 3 and from 1020 to 1023 (3FC - 3FF hexadecimal). Values in this range are used exclusively for synchronization word sequences prefacing EAVs, SAVs, and ancillary data packets. The luminance and chrominance samples stored within the active picture area are further limited, as shown in Figure 9, to represent the proper ranges of luminance and chrominance levels. For instance, a luminance level of 64 maps to black, and 940 maps to peak-white.

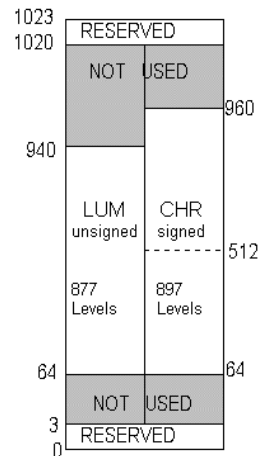
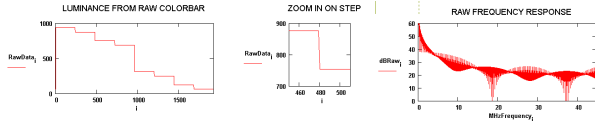

Figure 9 – 10-bit Luminance and Chrominance Data Ranges

The regions marked “NOT USED” in Figure 9 are out of the range of nominal values for luminance and chrominance. These values may be used to accommodate overshoot and undershoot in video processing, but avoiding these values is recommended.

## Data Filtering

Luminance and chrominance values within the active area represent analog video components in the real world, and therefore, are also limited in the bandwidth of their representation. For instance, it is not permitted to have a black (64) pixel next to a white (940) pixel, as this represents high frequencies that are not within the realizable band. Figure 10 shows an example of the step-response produced by such “unfiltered” edges. In this example, a 74.25 MHz sample clock can theoretically realize a 37.125 MHz response, yet higher frequencies are present in the spectrum analysis.



**Figure 10 – Unfiltered Luminance Response**

It is mandatory to filter the raw values to limit the represented frequencies so aliasing doesn’t occur. One popular method shown in Figure 11 is to pass a Gaussian-shaped filter over data. This is attractive, especially since it produces nicely smooth transitions with no overshoot. This technique is successful in limiting the spectrum of the resulting signal, but the attenuation of higher in-band frequencies is considerable.

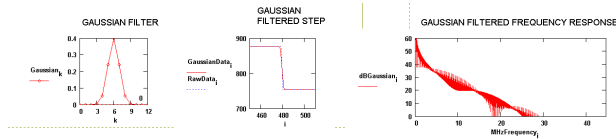

**Figure 11 – Gaussian-Filtered Luminance Response**

Another popular method shown in Figure 12 is to pass a Sync-shaped filter over the data. This has the disadvantage that it produces overshoot in transitions. For instance, using this filter on a step-transition from black (64) to white (940) would result in values that extend beyond the legal range (64-940). However, this filter does produce a spectrum with more “shoulder,” thus preserving more higher in-band frequencies than the Gaussian approach.

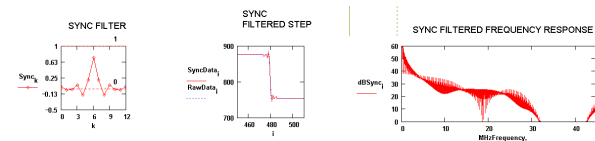
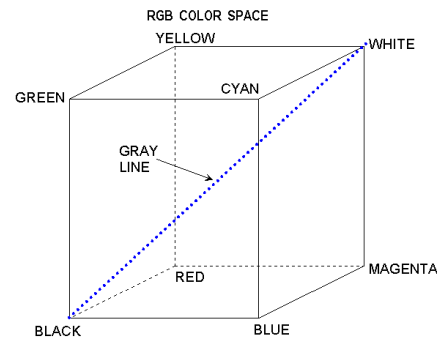

**Figure 12 – Sync-Filtered Luminance Response**

## Color Gamut

The luminance and chrominance samples form a three-part numeric value that represents a combination of red, green, and blue primaries presented to the human eye by

the television system. In the RGB primary color system, any amount of individual components of R,G,B can be combined to create a visible color. On a three-dimensional Cartesian coordinate system, this gamut can be represented as a cube, as shown in Figure 13.



**Figure 13 – RGB Colorspace**

Red, green, and blue values are not transmitted in television systems because historically, black & white television displayed luminance only, and subsequent color systems were made to be backwards compatible by modulating color components on top of the luminance signal. This provided the need for a separate luminance component, which is also advantageous because the human eye is much more capable of resolving luminance than chrominance. Having a separate luminance component enables allocation of more signal bandwidth to luminance than to chrominance; hence 4:2:2 sampling, which samples the luminance component twice as fast as either chrominance component.

The other two components could have been from a polar color coordinate system, like hue and saturation, however processing in polar coordinates is fairly difficult compared to linear coordinate systems. B-Y and R-Y were chosen over G-Y since, of the three primaries, green has the most luminosity, which was already represented by the luminance component. The resulting Y,B-Y,R-Y colorspace (Figure 14) has a separate component representing luminance, it is a linear algebraic space, and it represents a convex shape that is required so that “mixing” between any two legal colors is guaranteed to produce a sequence of legal intermediate colors.

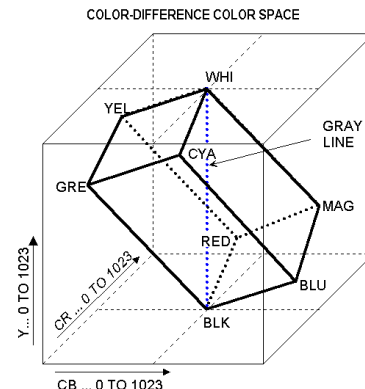

**Figure 14 – Y, R-Y, B-Y Colorspace**

Notice that the visible colors represented by the RGB cube fit within the Y,R-Y,B-Y colorspace, and that there are many possible combinations of Y, B-Y, and R-Y that do not map into the RGB cube. These Y,R-Y,B-Y combinations do not represent properly visible colors. This sort of errored combination of Y, R-Y, and B-Y values creates an RGB “Gamut Error.”

### Color Transformations

The method for transforming between an R,G,B value and its corresponding Y,R-Y,B-Y representation requires a transformation matrix defined by the source format. The 1080-I and 720-P source formats utilize a matrix defined by the ITU-R BT.709 specification<sup>5</sup>. The 1035-I source format utilizes a matrix defined by the SMPTE 240M specification<sup>6</sup>.

$$\text{BT709} := \begin{bmatrix} 0.2126 & 0.7152 & 0.0722 \\ 0.50 & -0.4542 & -0.0458 \\ -0.1146 & -0.3854 & 0.50 \end{bmatrix} \quad
 \text{Smpte240} := \begin{bmatrix} .212 & .701 & .087 \\ 0.5 & -0.445 & -0.055 \\ -0.116 & -0.384 & 0.50 \end{bmatrix} \quad
 \text{Rec601} := \begin{bmatrix} .299 & .587 & .114 \\ .5 & -.419 & -.081 \\ -.169 & -.331 & .5 \end{bmatrix}$$

**Figure 15 – Color Transformation Matrices**

As shown in Figure 15, neither of these matrices match the one used by standard definition video systems, which is defined in ITU-R BT.601<sup>7</sup> and SMPTE 125M<sup>8</sup>.

The difference between the BT.709 and SMPTE 240M color transformation matrices is slight. For instance, Figure 16 shows a vectorscope display produced from a SMPTE 240M 100% colorbar signal, as compared with “targets” set for the ITU-R BT.709 color gamut specification.

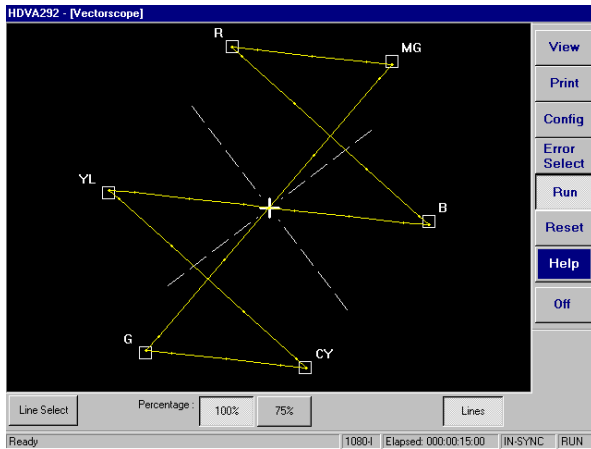

**Figure 16 – Vectorscope shows Gamut Differences**

### Switching Line

The “switching line” refers to a designated video line where switches between video feeds can take place. The significance of the switching line is that depending on the clocking mechanisms of the two sources being switched, time may be required to allow for clocks to “settle” as phase lock loop circuits react to the change in input. For

this reason, the line after the switch point is usually kept free of important data.

The specifications for switching lines are unfortunately not presently defined in SMPTE 292M. The 1080-I and 1035-I systems both reference SMPTE 299M<sup>9</sup>, which is the specification for 24-bit Embedded Audio. In this specification, lines 7 (field 1) and 569 (field 2) are specified as the switching lines. The 720-P specification presently does not have a de facto switching line. Ongoing work within the SMPTE organization should remedy this situation.

### Auxiliary Data Embedding

The SMPTE 292M specification indicates that the SMPTE 291M<sup>10</sup> specification (Ancillary Data Packet and Space Formatting) is a “normative” reference, hence including the SMPTE 291M material into the SMPTE 292M specification.

The Ancillary Data Packet and Space Formatting specification, SMPTE 291M, was originally envisioned as a means to multiplex small packets of data into a standard definition serial digital link. Since the packet-embedding SMPTE 291M standard already existed, and since SMPTE 292M high definition SDI has such strong similarities with standard definition SDI, using the former methodology was attractive.

The basic structure of ancillary data packets is shown in Figure 17. The second packet type, which permits a secondary packet type identifier, was defined as an extension of the first since single-byte packet type identifiers were deemed too restrictive. The different packet types are discernable based on the most significant bit of the primary packet type identifier.

Ancillary data packet - Type 1

ADH - Ancillary Data Header 000 3FF 3FF	DID - Data ID	DBN - Data Block Number	DC - Data Count	UDW - User Data Words (max 255 bytes)	CS - Checksum

Ancillary data packet - Type 2

ADH - Ancillary Data Header 000 3FF 3FF	DID - Data ID	SDID - Secondary Data ID	DC - Data Count	UDW - User Data Words (max 255 bytes)	CS - Checksum

**Figure 17 – Ancillary Data Packet Format**

Embedded packets should only be inserted into the horizontal and vertical ancillary data space. Packets should be left justified within the space when possible. Packets should not rely on being placed in a particular location (although some applications exist which do). Packets that are no longer useful may be marked with a Data ID (DID) of 0x80-0x8, which enables downstream equipment to identify them and remove them. At the end of each line’s embedded packets, it is recommended that a small packet with a DID of 0x84-0x87 be inserted to indicate the end marker. Packets should not be inserted on the line right after the switching line.

One significant difference between the standard definition and high definition applications is that standard definition

SDI is generally considered a single stream of 10-bit samples, even though the video data portion of the signal is a multiplex of combined 10-bit luminance and 10-bit chrominance data. In high definition SDI, the multiplexed luminance and chrominance streams retain their individuality even within the ancillary data space, and so there are two separate ancillary data packet channels available for application use.

Three limitations to this packet structure are:

- a.) the largest number of unique packet identifiers is roughly 32K;
- b.) the largest number of user data words per packet is 255;
- c.) the standard only defines embedding information into the ancillary data space – packets may not be placed in the active picture area.

There is ongoing work within SMPTE working groups to address some of these issues.

### Embedded Audio

Digital audio can either accompany a video signal as a separate AES3 digital audio signal<sup>11</sup>, or it can be multiplexed into the high definition serial digital signal using the previously mentioned auxiliary data packet embedding techniques.

Embedding digital audio is specified by SMPTE 299M – 24-Bit Digital Audio Format for HDTV Bit-Serial Interface<sup>12</sup>. This standard defines up to four groups of four channels of digital audio, for a total of 16 audio channels that can be multiplexed into one video stream. There is considerable room in the horizontal ancillary data space, and extensions to provide additional channels may be forthcoming. (The ATSC standard for HDTV includes Dolby AC3™ that produces a theater-quality experience with six independent channels of audio. It is common for present video equipment to have four channels of audio, and enabling AC3 will require changes. Work is proceeding on encoding all six channels into one AES3 digital audio pair. This will require large amounts of compression, however, and will likely not be sufficient for contribution-quality systems.)

SMPTE 299M embedded audio information is split into two categories. First, there are audio data packets that contain the actual audio samples that comprise pulse code modulation (PCM) samples of the analog audio waveform. The sampling rate is usually 48.0 KHz, but it may also be 44.1 or 32.0 KHz. The other information category is control information. Control packets indicate what sampling rate is in use, an “audio frame number” used for synchronization with video frames, and the amount of accumulated audio processing delay relative to video. All audio channels in a given audio group have identical sampling rate, sampling phase, and asynchronous/synchronous nature.

As shown in Figure 18, audio control packets are inserted into the luminance ancillary data space twice per frame. Audio data packets are inserted continuously into the chrominance ancillary data space.

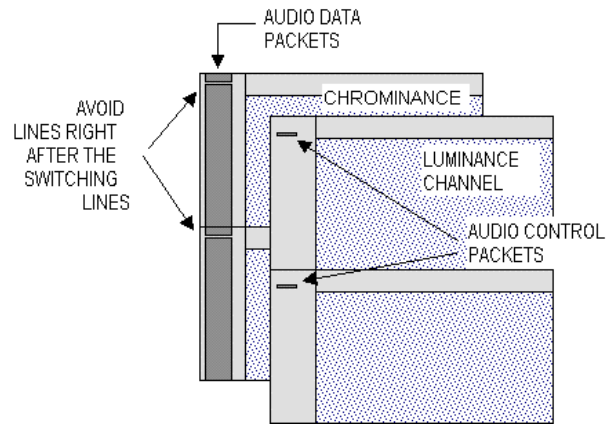

**Figure 18 – Embedded Audio Mapping**

Audio data samples are protected from errors by the addition of forward error correction (FEC) to each embedded audio data packet. The FEC code is from a family of forward error correction codes invented by Bose, Chaudhuri, and Hocquenghem, called a BCH(31,25) code. It can detect and correct up to three words of error within the embedded audio data packet.

The structure of the embedded audio data packet is shown in Figure 19.

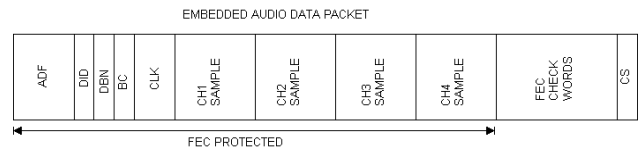

**Figure 19 – Embedded Audio Data Packet**

There are many layers of protocol required to implement high definition systems transmitted over the SMPTE 292M interface. During development and manufacturing, each layer provides an opportunity to apply testing techniques to verify protocol and standards compliance.

### Testing Methods

As shown, there are many layers of protocol required to implement digital high definition systems transmitted over the SMPTE 292M interface, including:

- a.) Serial Waveform
- b.) Serial Conversion
- c.) Data Framing
- d.) Data Code Restrictions
- e.) Data Filtering
- f.) Color Gamut
- g.) Switching Line

- h.) Video Presentation
- i.) Auxiliary Data Embedding
- j.) Embedded Audio

Each of these areas requires design-level testing during a digital high definition product development cycle.

### Testing Serial Waveform

The SMPTE 292M serial waveform can be tested using multiple techniques including eye diagram, signal spectrum, jitter vs. time, and jitter spectrum analysis, and impedance testing with a time domain reflectometer.

Eye diagram testing and Jitter analysis are very popular methods for standard definition systems. In order to effect these tests, it is critical to create a time base that is as free from jitter as possible. SMPTE RP-184<sup>13</sup> and EG-33<sup>14</sup> describe methods for creating this time base and making jitter measurements.

A common approach, called clock extraction method, creates a clock using PLL techniques based on an input signal. This is shown in Figure 20. The divisor reduces the input frequency into the range of economical phase comparators. The divisor can be any number, although it is recommended not to use a divisor of ten (10), since this may mask 10-bit word-correlated jitter.

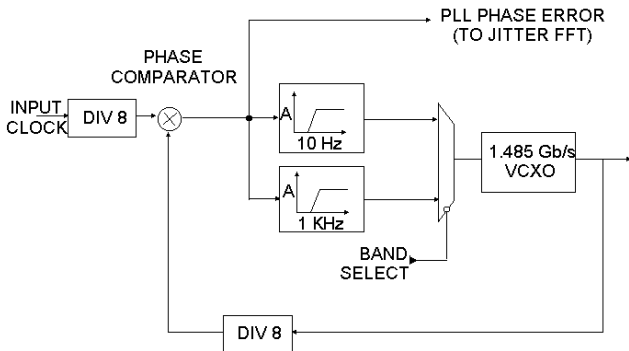

**Figure 20 – Clock Extraction Method**

The divided-down recovered clock can then be used as a trigger to an oscilloscope, which can then display the “eye pattern” of the SMPTE 292M signal. Depending on the bandwidth of the PLL used in clock recovery, different sources of jitter can be distinguished. SMPTE RP 184 techniques define “timing jitter” and “alignment jitter.” Timing jitter refers to all phase variations between the input signal and a theoretically perfect 1.485 Gbit/sec oscillator. Since extremely low-frequency jitter (wander) is a separate consideration, typically, a 10 Hz minimum band edge frequency is utilized for measuring timing jitter. Alignment jitter refers to phase variations between the input signal and a clock recovered from the input signal with a suitable PLL. The frequency range for alignment jitter starts at 1 KHz, since typically jitter frequencies below this are removed by the clock recovery PLL.

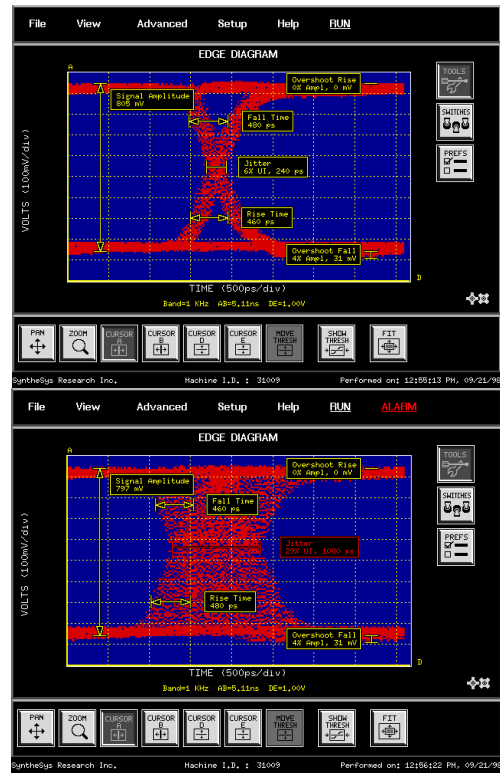

**Figure 21 – Edge™ Diagrams (Example SDI signal)**

The Edge™ diagram is useful as it gives a quick synopsis of a number of important serial waveform parameters including rise time, fall time, peak-to-peak amplitude, peak-to-peak jitter, and overshoot. It also shows waveform distortions that are associated with problems. Large amounts of jitter reduce the value of this diagram since the “eye” (located to the right and left of the edge) becomes less and less visible. Figure 21 demonstrates an Edge diagram.

In these cases, examining jitter vs. time, with a suitable time base such as one horizontal line or one frame, is useful. One very succinct method of jitter analysis is to perform FFT analysis upon the jitter signal. This technique often identifies specific systematic jitter sources by indicating component jitter frequencies within the wide band, peak-to-peak jitter visible in the Edge™ diagram.

Impedance matching is critical at 1.485 Gbit/sec data rates. Testing that the 75 Ohm impedance is constant throughout the signal path can be accomplished using a time domain reflectometer. This tool can map out the impedance discontinuities caused by cable, connectors, PWB interfaces, PWB signal traces, and other components on the net. These impedance discontinuities will cause reflections, distortions, and ultimately, bit errors.

### Testing Serial Conversion

Serial conversion includes randomization, NRZi encoding, and signal equalization. The process of performing the randomization and NRZi encoding is

straightforward and testable by logic simulations aimed at validating encoder and randomization logic. The features that encoding and randomization provide to the SMPTE 292M signal can be tested by passing exercising data through the system. This data tests the equalizer's ability to equalize non-DC-free signals. It also tests the PLL's ability to perform clock recovery when the number of signal transitions is reduced.

The "pathological" test pattern has two parts dedicated to testing the equalizer and PLL. The test pattern is defined in SMPTE EG 34, Pathological Conditions in Serial Digital Video Systems<sup>15</sup>.

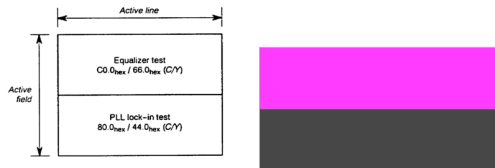

**Figure 22 – Pathological Test Pattern<sup>16</sup>**

The test pattern is effective for testing the equalizer performance in the face of DC content, which is normally removed from the signal by the randomizer. As shown in Figure 23, the particular 20-bit sequence, 0x300-0x190, when processed by the randomizer and the NRZi encoder produces a bit sequence that has 19 ones and 1 zero; a DC-free sequence would have the same numbers of ones and zeros.

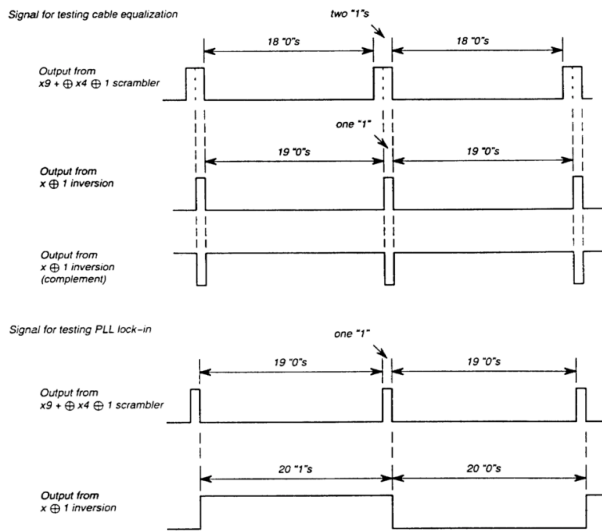

**Figure 23 – Equalizer and PLL Pathological Sequences<sup>17</sup>**

Similarly, the bottom portion of the test pattern contains the 20-bit sequence, 0x200-0x110, which is transformed by randomization and channel encoding into a bit sequence containing 20 ones followed by 20 zeros. This is the longest absence of transitions possible, which is very difficult for a PLL to "freewheel" through.

Other indirect methods of testing the serial waveform include purposely injecting distortions and jitter to see how the system reacts to these situations. Cable simulators, real lengths of cable, and jitter injectors can be used to determine the "headroom" of the system. Digital failures produced by these affects can be evaluated by monitoring CRC failures for the CRC words contained on each line in the SMPTE 292M standard.

### Testing Data Framing

Testing data framing amounts to verifying the contents and placement of framing words contained in the SMPTE 292M signal. This can be done either by capturing these words and manually verifying their contents, or by using application-specific test equipment that performs this function.

Some of the tests that are possible include:

- a.) SAV and EAV placement
- b.) SAV and EAV contents (F-bit, V-bit, H-bit, XYZ-value)
- c.) CRC word placement
- d.) CRC value calculations
- e.) LINE NUMBER placement
- f.) LINE NUMBER values

Testing each of these conditions during development can verify implementation of the SMPTE 292M standard. It is convenient to analyze specific numeric data values associated with error conditions. Since these conditions form the basis for valid synchronization to a received signal, ongoing tests of these systems are also a good quality metric for installed systems.

### Testing Data Code Restrictions

The SMPTE 292M standard defines separate value ranges for valid luminance and chrominance sample values within the active picture area. It also defines special "reserved code" values used for synchronization. As described previously, valid luminance values range from 64 to 940, valid chrominance values range from 64 to 960, and reserved codes range from 0 to 3 and from 1020 to 1023. Testing for values not conforming to this specification should be done on a real time basis to locate errors at any pixel location. The reserved codes are very hard limits set forth in the specifications. The active picture data ranges, however, are soft limits since, as shown with the case of the sync filter, some processing can extend beyond the legal limits. For this reason, it is convenient to have means for selecting the data ranges which cause error detection.

### Testing Data Filtering

Data filtering can be verified by determining the spectrum of signals represented by the pixels processed by the high definition system. One approach is to acquire one frame

of data from the signal being analyzed, to extract one horizontal line or one vertical column, and then to decompose the luminance and chrominance values into separate data sets. These sets can then be processed with an FFT algorithm. The results are normalized by converting them to dB units and then displayed. Figure 24 shows a simple MathCAD™ worksheet that performs this analysis based on a previously acquired line of horizontal data.

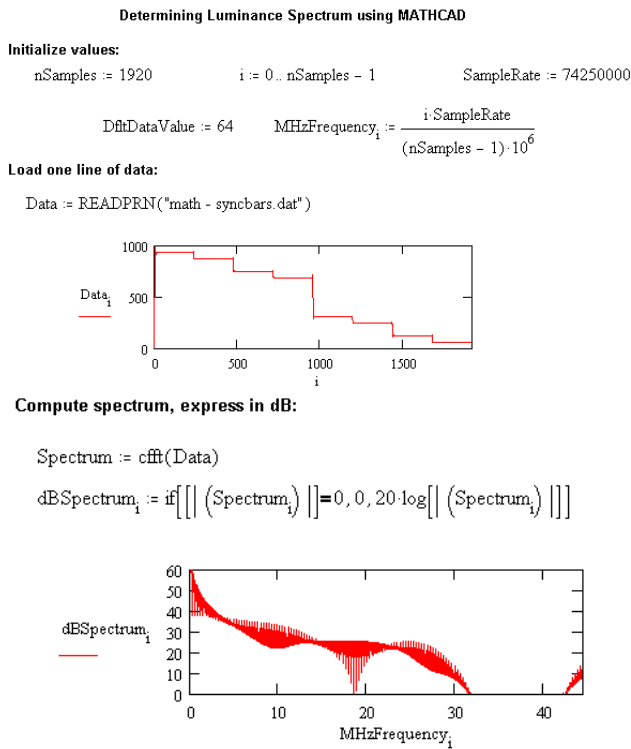

**Figure 24 – FFT Worksheet in MathCAD™**

This technique works equally well with vertically organized data if analysis of vertical frequency response is required. MathCAD is also very useful for designing the filters used to process digital video data.

Useful tools for performing spectrum analysis include a means for acquiring pixel data and exporting it to spreadsheet and mathematics programs.

### Testing Color Gamut

Two types of tests are important for color gamut testing. The first is to test the color transformations used a particular system, and the second is to test individual pixel color values to determine if any of them form illegal R,G,B values (RGB Gamut Error Checking). The first type of test can be accomplished by transmitting a known colorbar pattern through the system under test, and viewing the results on a vectorscope display, or on an R,G,B waveform display.

The vectorscope traditionally offers “targets” indicating exactly where the colorbar color values should reside. Displays that show signals landing outside the targets indicate incorrect color transformations.

The R,G,B waveform monitor display of a 100% colorbar signal is easily identifiable, since it represents full levels of each primary color in a simple pattern. The vectorscope and R,G,B waveform monitor displays are shown in Figure 25.

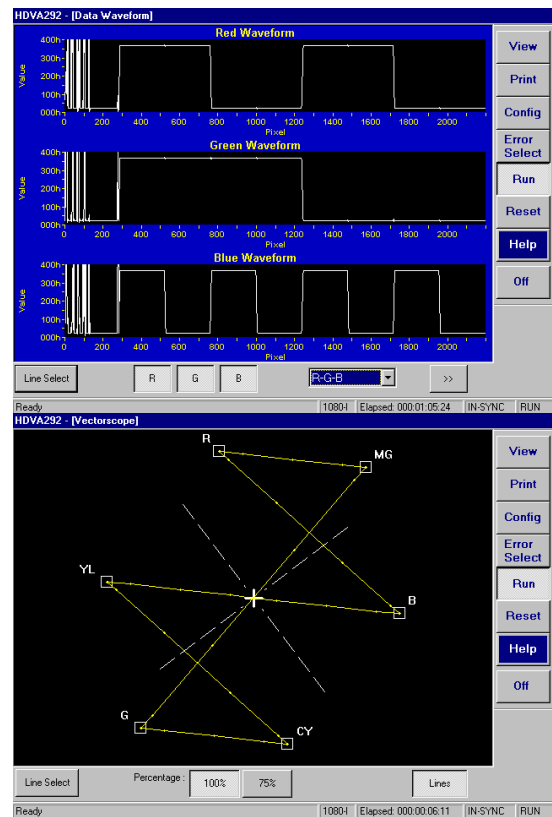

**Figure 25 – R,G,B Waveform and Vectorscope**

Testing for R,G,B Gamut errors requires real time transformation of every active picture Y,R-Y,B-Y value and subsequent determination of whether or not the resulting R,G,B values are legal.

### Testing Switching Line

The switching line defines a point within a frame that a downstream switching device may choose to discontinue transmitting one video source and replace it with another. Hence any data, particularly ancillary data, stored on lines prior to the switching line may end up being associated with the first frame of another video source. It is therefore important to insert all ancillary data packets that are associated with a particular frame, after the switching line. It is also important to leave the line after the switching line free from any ancillary data, to accommodate PLL settling times required by downstream receivers after the switch.

In order to test switching line issues, a system is required which locates ancillary data packets and can determine their line location. This mechanism can be used to make sure the line after the switching line is free from ancillary data packets. Designers of ancillary data applications may also wish to verify that their packets are inserted on the appropriate lines for proper association with particular frames.

## ***Testing Video Presentation***

Looking at numeric pixel values is critical for digital system verification, but there are still some very good uses for video oriented testing. Many test patterns exist which are good stimulus for analog and digital processing. These test patterns are designed to be examined with particular video oriented analysis techniques, such as 1H waveform display, vectorscope, or a picture monitor.

Waveform monitor and vectorscope applications have been discussed previously. Picture monitors help quickly identify the source material being tested and demonstrate gross problems with the signal. Often times gamut errors and illegal data values present themselves in very visible ways. Synchronization problems cause monitors to come “unlocked.”

## ***Testing Auxiliary Data Embedding***

Auxiliary information is embedded into the SMPTE 292M signal in two independent channels (luminance and chrominance) following SMPTE 291M packet-embedding protocols. These protocols define a standard packet format containing a common header indicating the presence of application-specific user-data words. Packets are preceded by ancillary data flags, and they must be contained within horizontal or vertical ancillary data space.

To test embedded data packets, each packet may be interrogated and examined for obvious error conditions. For instance, there are parity bits for all header words that can be checked. There is a checksum word at the end of the packet that can be checked. The completeness of each embedded data packet can also be verified to make sure other packets or framing words don't interrupt the embedded packet.

For standards that have switching line defined, this defines a point before which ancillary data will be associated with the previous field, and after which ancillary data will be associated with this field. The line immediately after the switch point should be kept free from ancillary data packets to protect against loss of auxiliary information due to disturbances caused by the switch.

## ***Testing Embedded Audio***

Embedded audio is one application of auxiliary information embedded into the ancillary data space using SMPTE 291M packet embedding techniques. As such, all embedded packet testing techniques are applicable to embedded audio transport testing. In the case of embedded audio, the content of the embedded data packets contains up to 16 channels of pulse-code modulated audio samples. The audio samples are stored along with forward error correction codes (BCH codes) that can be used for testing. Since only particular codes are valid, it is a relatively straightforward task to examine embedded audio packet contents and conclude if a bit error has occurred.

Besides testing the transport, the actual audio information can be further tested after it is demultiplexed from the SMPTE 292M transport. Noise measurements and stereo-pair measurements are routinely performed by AES3 digital audio analyzer tools.

Delay between audio stream and video stream is important to compensate for so that lip-synchronization is achieved. This delay can be measured by transmitting a series of video frames with accompanying audio data, and by measuring the difference in time between an obvious change in the video image and a corresponding change in the audio waveform.

## **Testing Tools**

General purpose test equipment, special purpose SMPTE 292M test equipment, and some custom engineering ingenuity are each required for successful high definition system development.

### ***General Purpose Test Equipment***

Every development lab must be equipped with basic general purpose test equipment including laboratory power supplies, basic hand tools, logic probes, oscilloscope, and logic analyzer. The SMPTE 292M signal transmits at 1.485 Gbit/sec, therefore, a multi-GHz oscilloscope is required to examine this serial stream. Logic analyzers are most often used in the parallel domain, after the serial stream has been paralleled into 10- or 20-bit words. 10-bit words transfer at 148.5 MHz and 20-bit words at 74.25 MHz, so logic analyzers must sample at these speeds, at least.

As waveform distortions caused by reflections from impedance discontinuities are more common problems when designing with very high data rates, a time domain reflectometer is a very useful tool during high definition system development. This tool can easily identify how cables, connectors, wiring assemblies, traces, and components affect the impedance and contribute to distortions.

### ***Application-Specific Test Equipment***

Presently, there are a number of manufacturers making test equipment specifically designed for SMPTE 292M signals; specifically, test pattern generators and signal analyzers/monitors. The following is a partial list of features provided by some/all of these test pattern generator (TPG) manufacturers:

#### **TEST PATTERN GENERATOR (TPG) FEATURES:**

- Multi-standard: 1025-I, 1080-I, 720-P
- Multiple frame rates: 60 Hz and 60/1.001 Hz
- Dual color gamuts (ITU-R BT.709 and SMPTE 240M)
- Multiple test patterns (fixed frames: colorbar, pathological, etc.)
- Embedded Audio
- Genlock

#### ADVANCED TPG FEATURES:

- Moving patterns
- Natural scenes
- Jitter Injection
- Digital Error Injection
- Noise Injection
- User patterns
- Selectable Ancillary Data Space
- Audio-delay measurement stimulus
- Remote Control

The following is a similar list of features required for SMPTE 292M monitors/analyzers:

#### SMPTE 292M ANALYSIS FEATURES:

- Real time format error detection (multiple types)
- Audio detection
- Error logging
- Error capture
- 1H-Line waveform
- Vectorscope
- Picture display
- Numeric display
- Hardcopy printing
- Networking

#### ADVANCED SMPTE 292M ANALYSIS FEATURES:

- 1.485 Gbit/sec eye diagram
- Reference-grade clock recovery circuit
- Jitter FFT
- Jitter vs. Time

For testing the embedded audio portion of SMPTE 292M signals, a combination of equipment including an embedded audio demultiplexer and an AES3 Digital Audio analyzer can be employed. This is particularly useful for making audio measurements on the transported audio channels.

### *Custom Testing Techniques*

Custom testing techniques often involve a combination of in-house tools and off-the-shelf test equipment hewn together with custom software or special-purpose software such as mathematics and realization programs and digital filter design packages. It is difficult to characterize these types of testing tools since they are usually home-brewed and designed to accomplish one specific task.

Sophisticated custom test fixtures may be developed by systems manufacturers to implement specific test plans for product manufacturing. Usually, this type of effort is only done if off-the-shelf equipment is not available. In the long run, maintaining custom test fixtures can become overwhelming. Using off-the-shelf components within an otherwise custom testing application is a good compromise between use of off-the-shelf equipment and complete customization.

## Automatic Design Verification Test

When developing a high definition system, being able to test design features quickly and completely is key to eliminating bugs and getting to market quickly. Automatic tests can iterate through all configuration possibilities and exhaustively test all features at full speed. Automatic testing is particularly good for quickly re-verifying all features after a fix to a particular bug has been implemented. Re-verifying all related functions in this situation is good engineering practice.

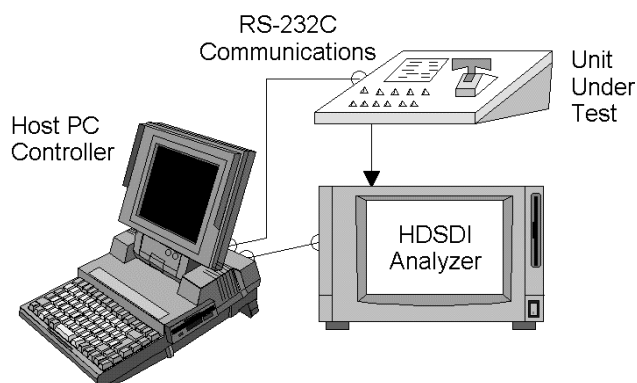

**Figure 26 – Automating Design Verification**

Some design verification can only be done by automatic means. For instance, environmental tests involving temperature chambers, shake tables, and EMI chambers are good candidates for automation.

Usually, automatic design verification involves simple remote control software programming to stimulate the device under test in specific circumstances to exercise individual features. Subsequently, the programs interrogate the system in some fashion to verify that the feature is operating correctly. This programming may be very sophisticated, but usually, since this level of testing is only performed during the engineering phase of a product's life cycle, it is developed quickly and simply gets the job done.

## Automatic Manufacturing Test

Automation during the manufacturing phase of a product's life cycle is even more important. Remote control programs can ensure that all tests are performed under precisely the same conditions and with precisely the same stimuli. Under these conditions, testing can be repeated to compare different systems and verify solutions to problems. Automated computer systems also eliminate the subjective analysis of test results, which can lead to inconsistent performance if more than one person is involved in testing a product.

Documentation is an important part of product manufacturing, and automated systems for manufacturing test usually perform this documentation function. These systems can print hardcopy results of test execution and can store electronic results. Ultimately, this type of testing system can provide a "Seal of Approval" for individual

machines, that companies can use to verify performance criteria before shipping. This information is also helpful thereafter as a baseline for comparing the machine's subsequent performance. This can be very important for technical support of the product once it's in the field.

## Conclusions

Like any other high definition system today, the development of application-specific test equipment, will be facilitated by lower cost receiver/transmitter solutions and by industry efforts to completely specify all aspects of the high definition signals.

SMPTE 292M high definition signal will achieve the same popularity as the SMPTE 259M signal as high definition systems become prevalent. There are many aspects of SMPTE 292M signal that require testing, including: serial waveform, serial conversion, data framing, data code restrictions, data filtering, color gamut, switching line, video presentation, auxiliary data embedding, and embedded audio transport.

General purpose test equipment, including oscilloscopes and logic analyzers, can be employed to test some aspects of the SMPTE 292M signal. These tools must accommodate the 5.5-fold increase in data rate, as compared to standard definition systems. In addition to these tools, SMPTE 292M application-specific test equipment, including test pattern generators and signal analyzers/monitors, are critically important for verifying correct operation compared to the official specifications. In fact, turnkey application-specific systems that test all aspects of the SMPTE 292M signal are preferred.

Automatic testing is important during system implementation to quickly verify functionality of all features. This aids in bringing systems to market more quickly, and in providing reliable and fast support to existing systems. Automatic testing during manufacturing provides accurate, repeatable tests, 24 hours a day. This also provides an audit-trail that documents system performance and promotes high quality.

## About the Author

Jim Waschura is a principal engineer and co-founder of SyntheSys Research Inc. His formal training is in computer science and mathematics, and he has spent over 13 years developing digital video and test and measurement products for the magnetics, communications, and television communities. He participates in SMPTE committee work and has authored several papers and patents. He can be reached via e-mail at [jim\\_waschura@synthesysresearch.com](mailto:jim_waschura@synthesysresearch.com). The company's website is <http://www.synthesysresearch.com>.

<sup>1</sup> ANSI/SMPTE 292M, Television – Bit-Serial Digital Interface for High-Definition Television Systems, The Society of Motion Picture and Television Engineers, White Plains, NY 10607

<sup>2</sup> ANSI/SMPTE 259M, Television – 10-Bit 4:2:2 Component and 4 f<sub>sc</sub> Composite Digital Signals – Serial Digital Interface, The Society of Motion Picture and Television Engineers, White Plains, NY 10607

<sup>3</sup> ANSI/SMPTE RP 184, SMPTE Recommended Practice, Measurement of Jitter in Bit-Serial Digital Interfaces, The Society of Motion Picture and Television Engineers, White Plains, NY 10607

<sup>4</sup> ANSI/SMPTE 292M

<sup>5</sup> ITU-R BT.709, Parameter Values for the HDTV Standards for Production and International Programme Exchange, Radiocommunication Study Group 11, Question ITU-R 27/11, International Telecommunication Union, Geneva, Switzerland

<sup>6</sup> ANSI/SMPTE 240M, Television – Signal Parameters – 1125-Line High-Definition Production Systems, The Society of Motion Picture and Television Engineers, White Plains, NY 10607

<sup>7</sup> ITU-R BT.601, Encoding Parameters of Digital Television for Studios, Radiocommunication Study Group 25, Question ITU-R 25/11, International Telecommunication Union, Geneva, Switzerland

<sup>8</sup> ANSI/SMPTE 125M, Television – Component Video Signal 4:2:2 – Bit-Parallel Digital Interface, The Society of Motion Picture and Television Engineers, White Plains, NY 10607

<sup>9</sup> ANSI/SMPTE 299M, Television – 24-Bit Digital Audio Format for HDTV Bit-Serial Interface, Society of Motion Picture and Television Engineers, White Plains, NY 10607

<sup>10</sup> ANSI/SMPTE 291M, Television – Ancillary Data Packet and Space Formatting, Society of Motion Picture and Television Engineers, White Plains, NY

<sup>11</sup> ANSI S4.40/AES3 Recommended practice for digital audio engineering – Serial transmission format for two-channel linearly represented digital audio data, Audio Engineering Society, New York, NY

<sup>12</sup> ANSI/SMPTE 299M

<sup>13</sup> ANSI/SMPTE RP-184

<sup>14</sup> ANSI/SMPTE EG 33, Engineering Guideline – Jitter Characteristics and Measurements, Society of Motion Picture and Television Engineers, White Plains, NY 10607

<sup>15</sup> ANSI/SMPTE EG 34, Engineering Guideline – Pathological Conditions in Serial Digital Video Systems, Society of Motion Picture and Television Engineers, White Plains, NY 10607

<sup>16</sup> ANSI/SMPTE EG 34

<sup>17</sup> ANSI/SMPTE EG 34



3475-D Edison Way  
Menlo Park, CA 94025 U.S.A.  
Tel 650 364-1853  
Fax 650 364-5716  
[info@synthesysresearch.com](mailto:info@synthesysresearch.com)  
[www.synthesysresearch.com](http://www.synthesysresearch.com)