

Simply Blue Bluetooth Profile Application Note

National Semiconductor
Application Note AN-1707
Sebastien Mathieu
September 2007



1.0 Introduction

This document explains the profile management and profile support on the Simply Blue Bluetooth modules from National Semiconductor.

2.0 Bluetooth Profile

A Bluetooth Profile is an application layer which guarantees the interoperability between devices of different manufacturers. A profile in general:

- follows required guidelines for a dedicated application
- is defined for specific applications and cases
- defines a selection of messages and procedures

Bluetooth profiles are divided into categories as described as example on Figure 1.

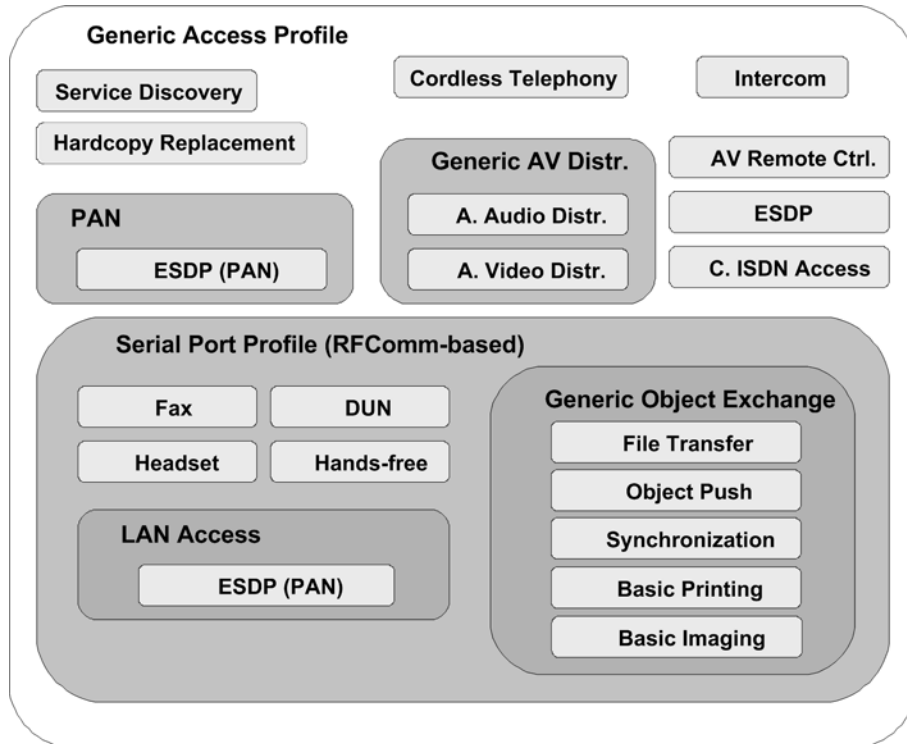

Figure 1. General Bluetooth Profiles

On an organization layer point of view, a Bluetooth Profile will be the top layer preceding the application as described on the Figure 2.

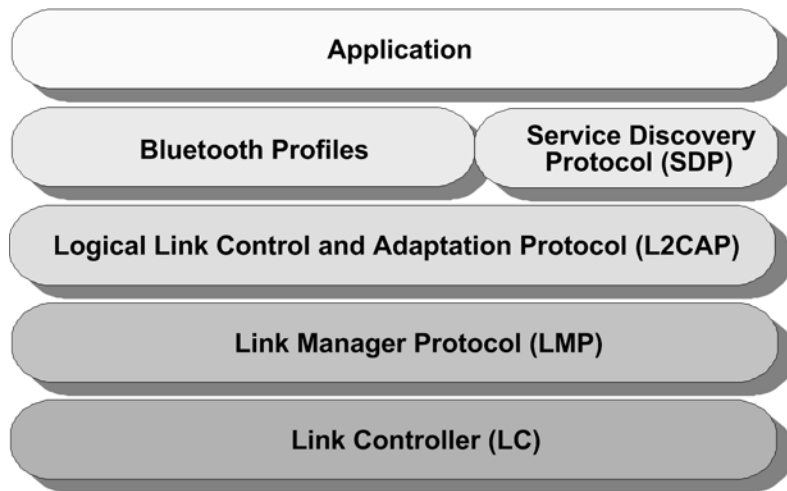

Figure 2. Bluetooth Profile Layer

The different profiles available are part of this Bluetooth profile layer as shown on the example below on Figure 4.

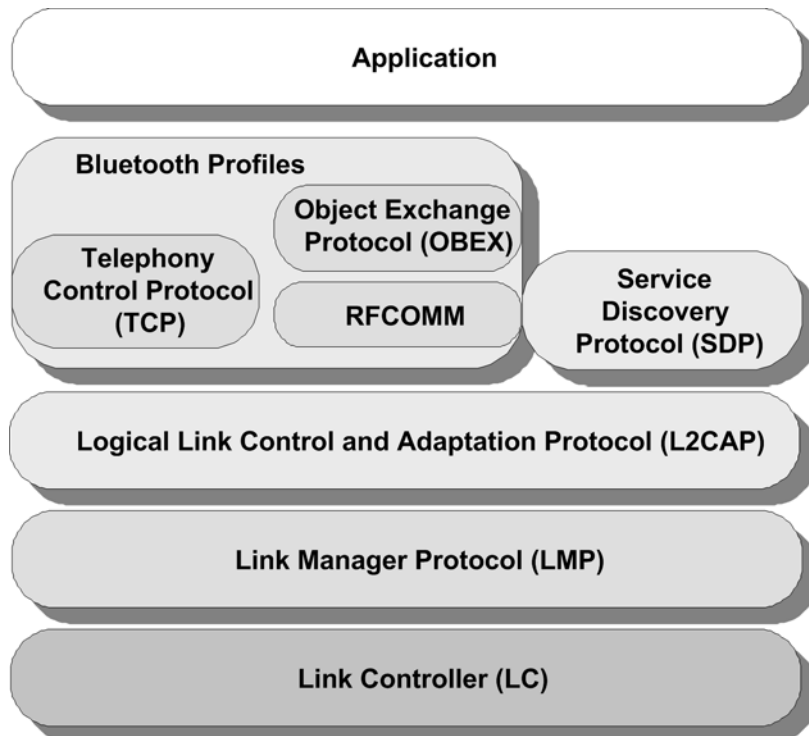

Figure 3. Detailed Bluetooth Profiles layer

3.0 Profiles on Simply Blue

3.1 IMPLEMENTED PROFILE

Simply Blue modules are qualified as complete Serial Port Module. Devices integrate the complete Bluetooth stack including Link Controller and Link Manager layers, the Gener-

ic Access Profile, the Service Discovery Protocol and the Serial Port Profile (SPP).

As described on the Figure 4 "Simply Blue Layer Structure", the only profile layer implemented in the module is the RFCOMM layer, which is the core of the SPP profile.

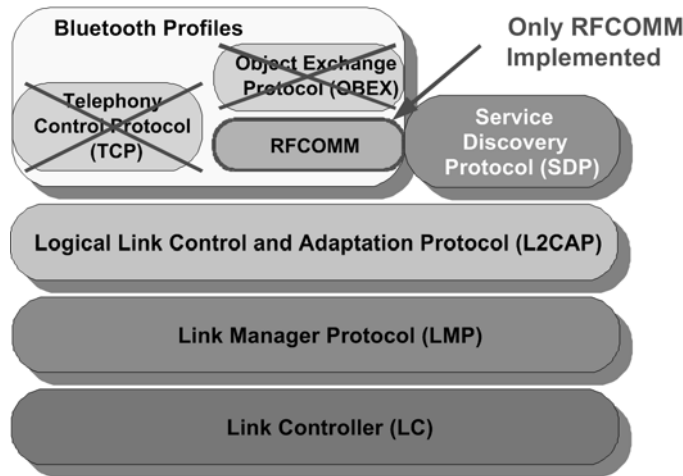

Figure 4. Simply Blue Layer Structure

Any other profile wanted needs to be implemented on the host as it is not already embedded in the module. Section 3.2 explains which profiles can be implemented on the host controller that will be supported by the module.

3.2 ADDITIONAL SUPPORTED PROFILES

As already covered in the Section 3.1, the only profile implemented in the module is the SPP. If the system requires more functionality, additional profiles can be supported by the Simply Blue module. However, those additional profiles have to be implemented on the host controller similar as the user application.

As qualified SPP modules, Simply Blue modules can not support all profiles available on the market. As a general rule, Simply Blue modules support all SPP based profiles, namely using the RFCOMM layer. As example, Figure 5 shows some of the supported profiles, and shows some of the non supported profiles.

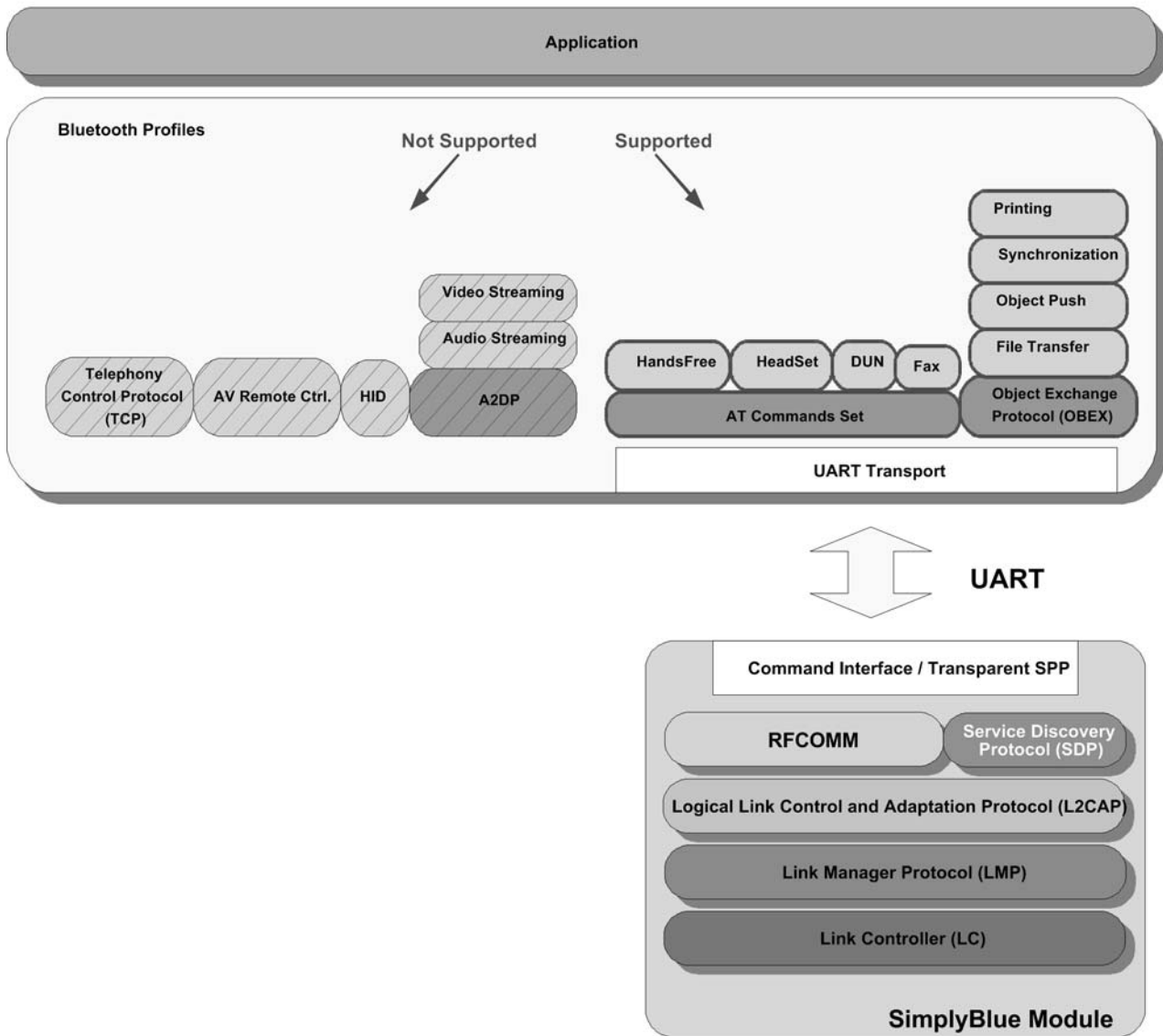

Figure 5. Supported profiles

4.0 Profiles implementation

This section explains the profiles implementation for SPP based profiles only.

The steps below explain how a profile can be initialized and activated.

4.1 SPP BASED PROFILE MECHANISM

Most of the SPP based profiles are easy to handle as the biggest software layer required is already implemented within the SPP profile and lower layers.

- 1) The first step consists in creating a service record representing the desired profile, mapped to a specific local port. Accessing this profile will be done by sending data to the dedicated local port.

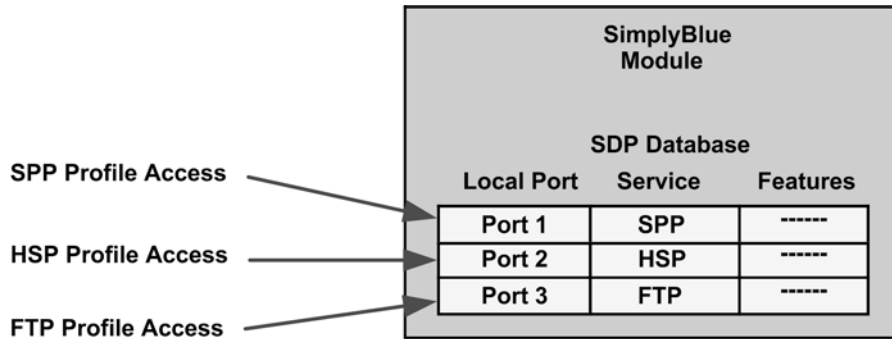

Example of a Service Database stored in a SimplyBlue module

- 2) To be able to initialize or activate a profile, an SPP link needs to be established between the 2 devices. Both local and remote devices need to support the profile and have the corresponding SDP entry in their data-

base. The link establishment can be initiated by either parts, the Simply Blue device or the remote device.



SB device initiates the SPP link establishment



Remote device initiates the SPP link establishment

- 3) Once the link is established, initializing the profile will consist in transmitting the right data (i.e. "AT Commands") over the established link to the remote device. The Simply Blue device acts basically as a

data gateway between the host device and the remote device.



Profile Data Sent/Received To/From the SB module

There are two ways of sending data to the Simply Blue module:

- Using command mode

Data have to be packed using the “Send SPP data” command as shown in this below example.

Table 1. AT command example (Command Mode)

Accept Call AT command	AT+CKPD=200
AT command in Hexadecimal format	41 54 2B 43 4B 50 44 3D 32 30 30 0D
AT command “packed” in Send data command	02 52 0F 0F 00 70 01 0C 00 <u>41 54 2B 43 4B 50 44 3D 32 30 30 0D</u> 03

- Using Transparent mode

Data can be sent directly to the Simply Blue module following the same model.

Table 2. AT command example (Transparent Mode)

Accept Call AT command	AT+CKPD=200
AT command in Hexadecimal format	41 54 2B 43 4B 50 44 3D 32 30 30 0D

Working with profiles consists in repeating step 2 to get the expected initialization and functionality, following the profile specification.

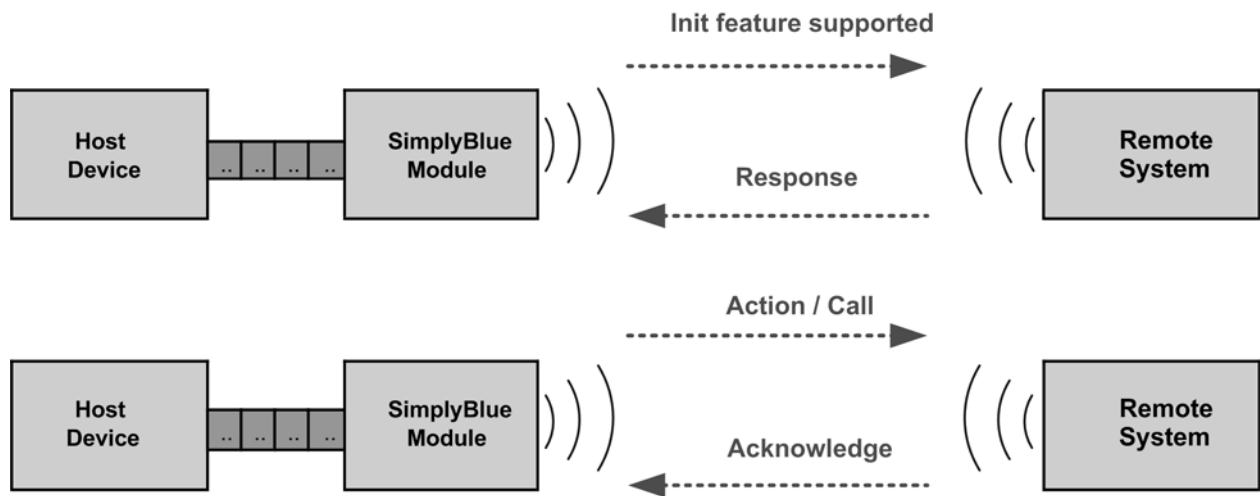

Profile steps example

All details can be found in the desired Profile specification available on <http://www.bluetooth.org>

The following gives all the details about the headset profile as reference and illustration of the above explanation.

4.2 PROFILE IMPLEMENTATION EXAMPLE: HEADSET PROFILE

The following description is based on [3]. Please refer to that document for complete description of the profile.

This Headset profile defines the protocols and procedures that shall be used by devices implementing the usage model called 'Ultimate Headset'. The most common examples of such devices are headsets, personal computers, and cellular phones.

The headset can be wirelessly connected for the purposes of acting as the device's audio input and output mechanism, providing full duplex audio.

The following roles are defined for this profile:

Audio Gateway (HSAG) – This is the device that is the gateway of the audio, both for input and output. Typical devices acting as Audio Gateways are cellular phones and personal computer.

Headset (HS) – This is the device acting as the Audio Gateway's remote audio input and output mechanism.

The profile specifies guidelines for incoming and outgoing connections for both profile roles, covering the following scenarios:

- AG initiated connection establishment
- HS initiated connection establishment
- Audio connection release
 - HS initiated
 - HSAG initiated
- Audio connection transfer
 - Transfer from HSAG to HS
 - Transfer from HS to HSAG
- Remote Volume Control

The following sections describe, how to use the Simply Blue Module as HSAG or HS.

4.2.1 AT Commandset and Results

The command line termination character shall be carriage return (0x0D). The response formatting character shall be line feed (0x0A). The HSAG shall not echo command characters (Opposite to default recommendation by ITU V.250). The HSAG shall transmit result codes, using the verbose (rather than numeric) format.

The format for a command from the HS to the HSAG is thus:

```
AT<cmd>=<value><cr>
```

If the command is processed successfully, the resulting response from the HSAG to the HS is:

```
<cr><lf>OK<cr><lf>
```

If the command is not processed successfully, the resulting response from the HSAG to the HS is:

```
<cr><lf>ERROR<cr><lf>
```

The format for an unsolicited result code (such as RING) from the HSAG to the HS is:

```
<cr><lf><result code><cr><lf>
```

The headset profile uses a subset of AT commands and result codes from existing standards.

Please see [1] for the complete list of commands necessary for the headset profile.

4.2.2 Acting as Headset

The headset is defined as the device, providing the input and output for audio data, e.g. microphone and speaker. The Simply Blue Module is able to connect an external codec via the on-chip advanced audio interface (AAI). Please see [1] for more details.

The HS side of the headset profile is mostly controlled by the Audio gateway. While the SPP link establishment can be initiated from both sides, the SCO link establishment will always be initiated by the HSAG. The Simply Blue Module will automatically accept incoming SCO links and report the successful establishment to the host.

The necessary configuration can be sum up by the following key points:

- Configure the audio path: Configure the codec and air interface used
- Create a Headset service record in the Service Database (SDB)
- Adapt the RFCOMM ports to open: Open the port to be in use by the Headset Profile
- Store the Class of Device (COD)

For more information on the detailed procedure, please refer to [1].

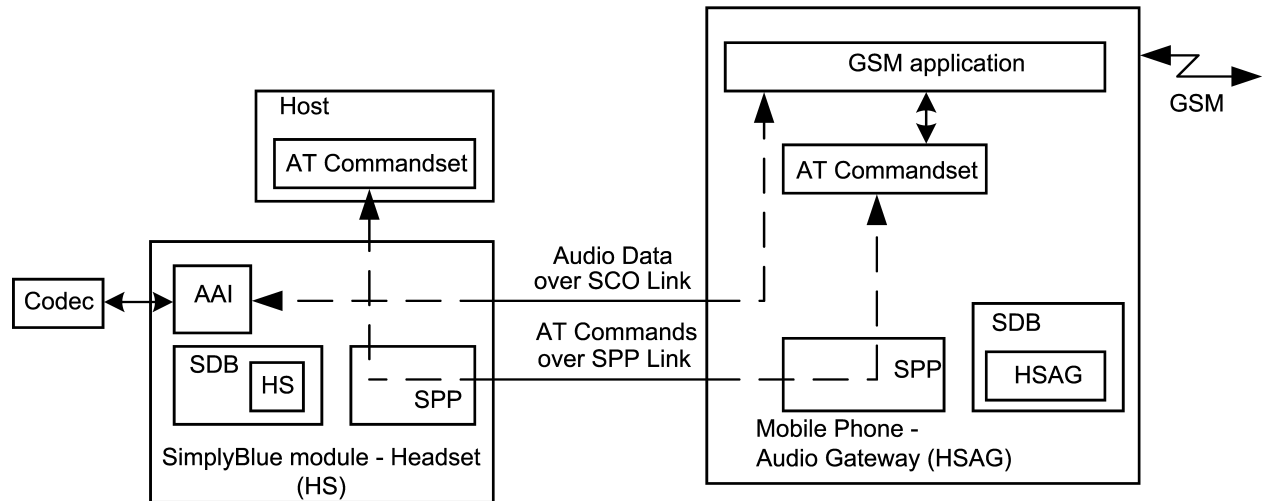

Figure 6. Headset Data and Audio stream

4.2.2.1 Connection handling as headset

The Headset profile is based on some specific AT commands also listed in Section 5.2 on page 24.

In a headset application the link will either be initiated from the HSAG or the HS itself. In both cases the HSAG will control the SCO link establishment. The HS will only react on incoming AT commands and maybe send the request for establishment or release.

The Simply Blue Module accepts incoming SCO links or SPP links automatically. It just indicates the successful establishment to the host. Therefore, for the HS implementation no further Simply Blue Module specific commands besides the already described configuration are required. The headset profile itself is controlled by a few AT commands.

The following chapters give the generic guideline of how to act as headset within the different scenarios.

4.2.2.2 Incoming audio connection

Figure 7 on page 9 shows the flow diagram of a headset link initiated by the HSAG as defined in [3].

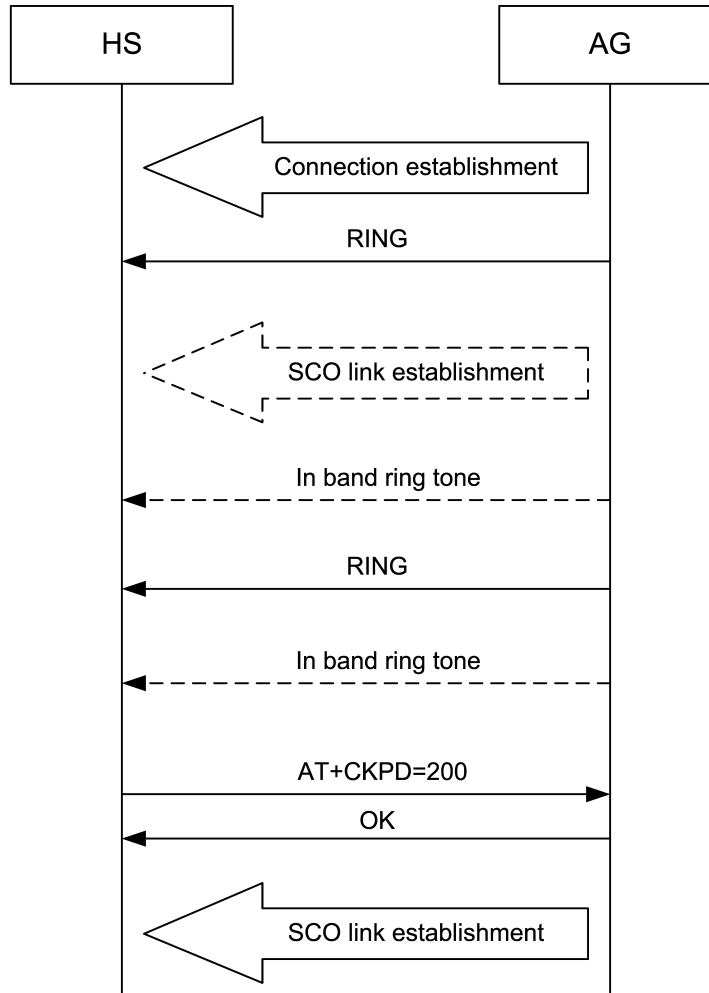

Figure 7. “Incoming audio connection establishment” as defined in bluetooth specification

As the specification figure already shows, the HS only needs to accept the incoming SPP and audio link and to indicate a button press by sending the “AT+CKPD=200” command. In addition the HS application needs to be able to recognize the RING command and the OK result code.

Please see Figure 8 which shows the headset part of the profile for the incoming audio connection ‘translated’ to the Simply Blue Module interface.

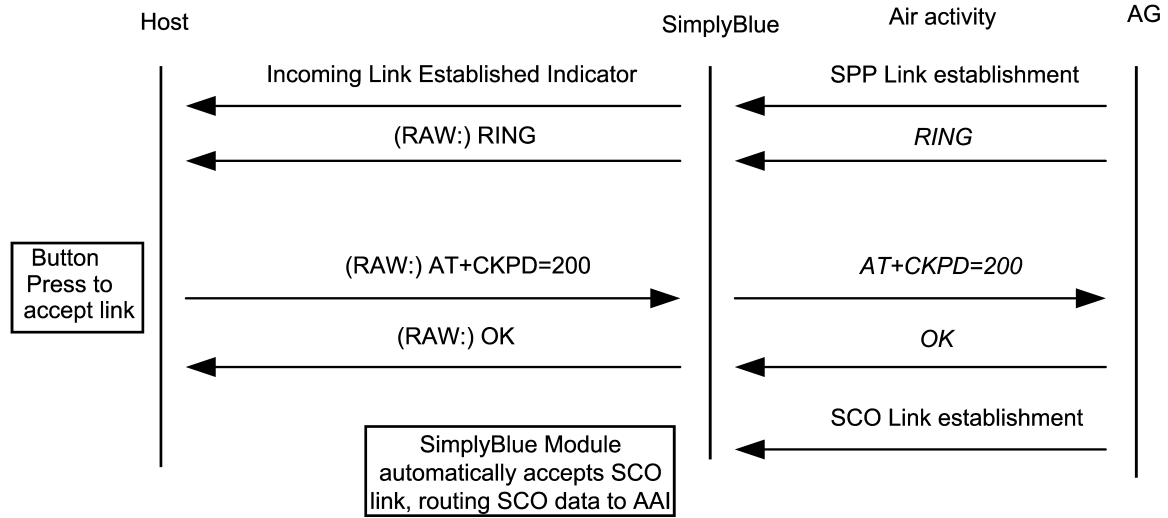

Figure 8. Incoming audio connection with Simply Blue Module as HS

Figure 8 shows the flow based on automatic mode, in which the Simply Blue Module will automatically switch to transparent mode on the UART. Please see the following table for the detailed description of the UART traffic between host and Simply Blue Module.

Table 3. Incoming audio connection with Simply Blue Module as HS

Direction	What	Hex Code	Interpreted by Simply Blue Commander
RX	Indicator	02,69,50,07,00,C0,B0,CF,22,17,00,08,00,03	Rx: Event: Incoming Link Established, BdAddr:123456789ABC, Local Port: 02
RX	RAW Data	0D,0A,52,49,4E,47,0D,0A	Rx(RAW): 0D,0A,52,49,4E,47,0D,0A (<i>RING</i>)
TX	RAW Data	41,54,2B,43,4B,50,44,3D,32,30,30,0D	Tx(RAW): 41,54,2B,43,4B,50,44,3D,32,30,30,0D (<i>AT+CKPD=200</i>)
RX	RAW Data	0D,0A,4F,4B,0D,0A	Rx(RAW): 0D,0A,4F,4B,0D,0A (<i>OK</i>)

After the final OK is received the audio link is established.

4.2.2.3 Headset initiated connection establishment

The Headset profile also defines the scenario in which the headset initiates the link to the HSAG. See Figure 9 on page 11 for the profile specification of the Bluetooth SIG.

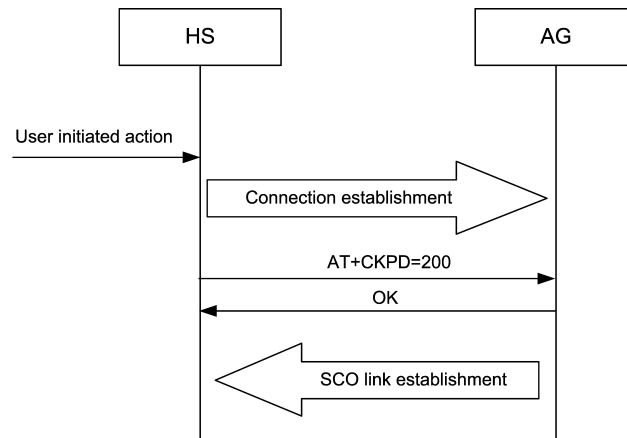

Figure 9. Outgoing audio connection establishment as defined by the Bluetooth SIG

As Figure 9 indicates, the headset basically only requests a SPP link and sends the AT+CKPD command. The rest is controlled by the HSAG. Therefore the link establishment is limited to the SPP link establishment and AT commands.

In order to establish a link to the HSAG, the headset needs to know the RFCOMM port number it has to connect on the remote device. Usually, these information are requested on first time of connection only. In order to get this RFCOMM

port number an SDAP procedure is needed. For more information on the SDAP request, please refer to [1].

Figure 10 and Table 4 show the final profile flow necessary to establish a connection to the HSAG with the Simply Blue Module.

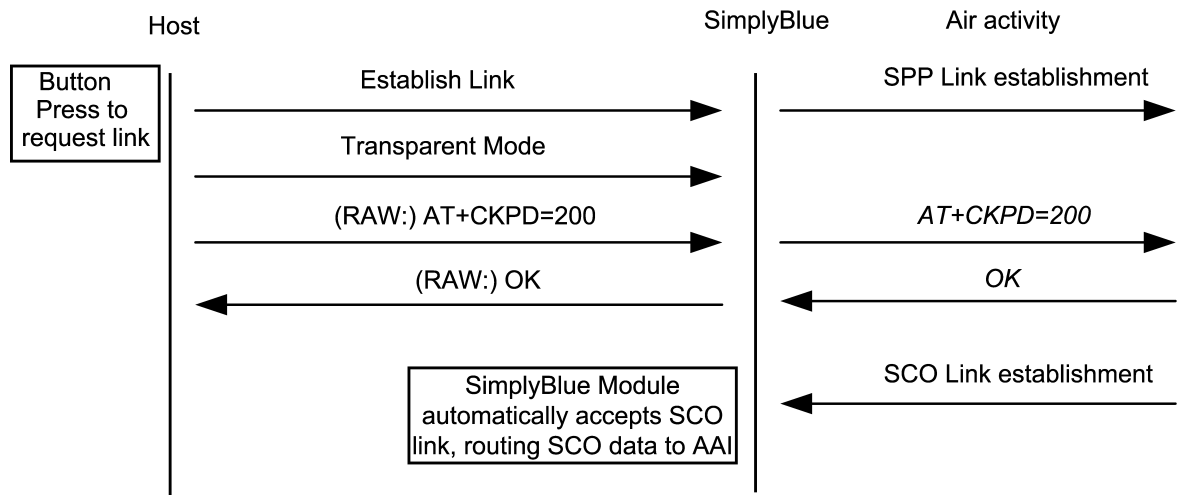

Figure 10. Outgoing link establishment from the Simply Blue Module as HS

Table 4. Outgoing link establishment from the Simply Blue Module as HS

Direction	What	Hex Code	Interpreted by Simply Blue Commander
TX	Request	02,52,0A,08,00,64,01,12,34,56,78,9A,BC,03,03	Tx: Cmd: Establish Link, Local Port: 01, BdAddr: 123456789ABC, Remote Port Number: 03
RX	Confirm	02,43,0A,02,00,4F,00,01,03	Rx: Event: Establish Link, Status: 00, Local Port: 01
RX	Indicator	02,69,50,07,00,C0,12,34,56,78,9A,BC,00,03	Rx: Event: ACL Established, BdAddr: 123456789ABC, Status: 00

Table 4. Outgoing link establishment from the Simply Blue Module as HS

Direction	What	Hex Code	Interpreted by Simply Blue Commander
RX	Indicator	02,69,0B,09,00,7D,00,12,34,56,78,9A,BC,01,03,03	Rx: Event: Link Established, Status: 00, BdAddr: 123456789ABC, Local Port: 01, Remote Port Number: 03
RX	Indicator	02,69,3E,04,00,AB,01,8C,00,00,03	Rx: Event: Port Status Changed, Local Port: 01, PortStatus: 8C, Break Length: 0000
TX	Request	02,52,11,01,00,64,01,03	Tx: Cmd: Transparent Mode, Local Port: 01
RX	Confirm	02,43,11,02,00,56,00,01,03	Rx: Event: Transparent Mode, Status: 00, Local Port: 01
TX	RAW Data	41,54,2B,43,4B,50,44,3D,32,30,30,0D	Tx(RAW): 41,54,2B,43,4B,50,44,3D,32,30,30,0D (AT+CKPD=200)
RX	RAW Data	0D,0A,4F,4B,0D,0A	Rx(RAW): 0D,0A,4F,4B,0D,0A (OK)

4.2.2.4 Audio connection release from the HS

The connection release is based on the same command as the connection confirmation, AT+CKPD=200. In case the user wants to release the link from the HS to the HSAG, it presses the same button again, which will send the same AT command. The HSAG will confirm by an OK and release the link.

The Simply Blue Module confirms the released link by the standard "SPP Link Released Indicator". See following the Bluetooth specification description for the realization with Simply Blue Module. In case the HSAG releases the link the Simply Blue Module will send the same event.

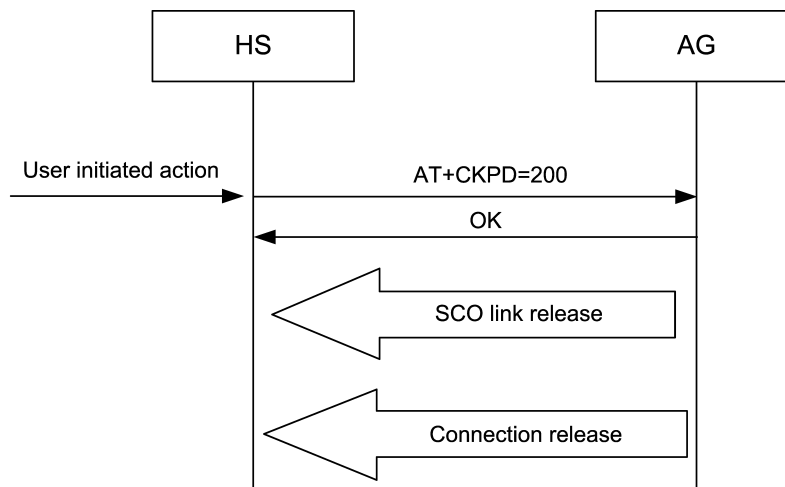

Figure 11. Audio link release by the HS

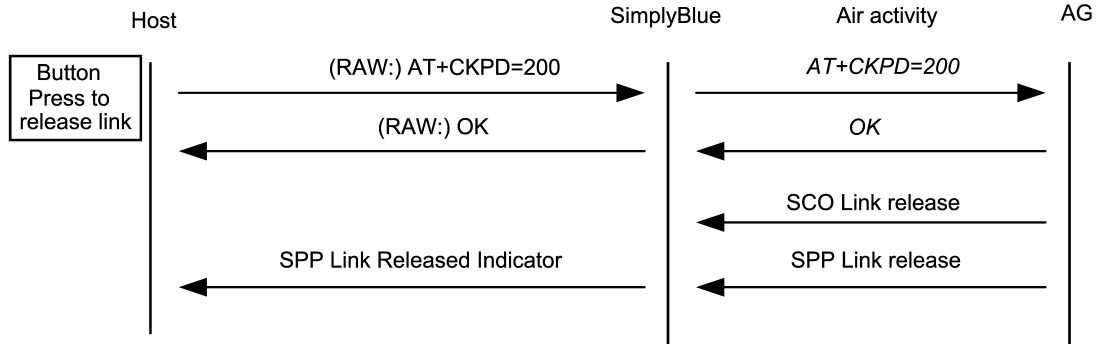

Figure 12. Audio link release from the Simply Blue Module as HS

Table 5. Audio link release from the Simply Blue Module as HS

Direction	What	Hex Code	Interpreted by Simply Blue Commander
TX	RAW Data	41,54,2B,43,4B,50,44,3D,32,30,30,0D	Tx(RAW): 41,54,2B,43,4B,50,44,3D,32,30,30,0D
RX	RAW Data	0D,0A,4F,4B,0D,0A	Rx(RAW): 0D,0A,4F,4B,0D,0A
RX	UART BREAK		Rx(RAW): 00
RX	Indicator	02,69,11,02,00,7C,01,00,03	Rx: Event: Transparent Mode, Local Port: 01, Mode: 00
RX	Indicator	02,69,0E,02,00,79,01,01,03	Rx: Event: Link Released, Reason: 01, Local Port: 01
RX	Indicator	02,69,51,07,00,C1,12,34,56,78,9A,BC,13,03	Rx: Event: ACL Terminated, BdAddr: 123456789ABC, Reason: 13

4.2.2.5 Audio connection release from the HSAG

In case the HSAG releases the audio link, no further AT commands are required. The HSAG just releases the SPP and SCO link. The host will be notified by the standard “SPP

Link Released Indicator” and “SCO Link Released Indicator”.

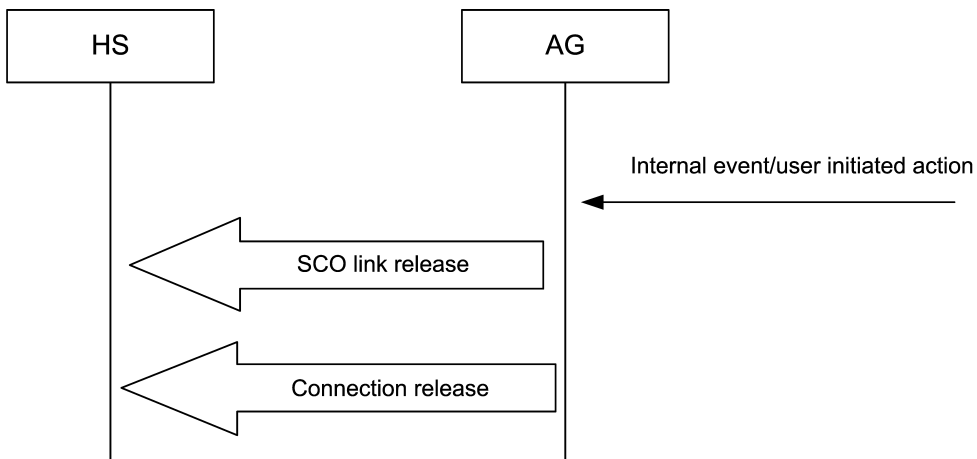

Figure 13. Audio link release by the HSAG

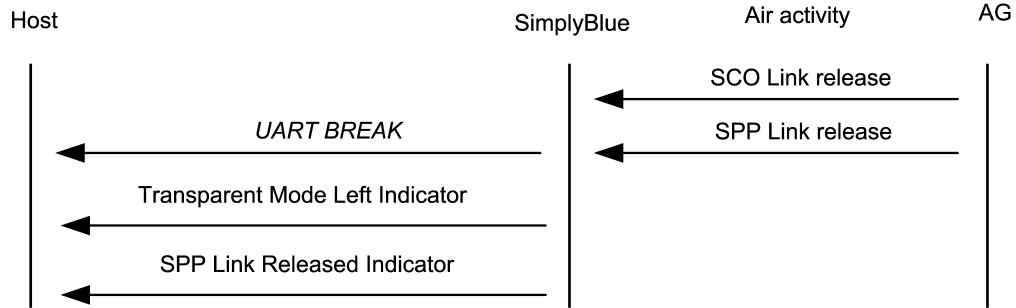

Figure 14. Audio link release by the HSAG

Table 6. Audio link release from the Simply Blue Module as HS

Direction	What	Hex Code	Interpreted by Simply Blue Commander
RX	UART BREAK		Rx(RAW): 00
RX	Indicator	02,69,11,02,00,7C,01,00,03	Rx: Event: Transparent Mode, Local Port: 01, Mode: 00
RX	Indicator	02,69,0E,02,00,79,01,01,03	Rx: Event: Link Released, Reason: 01, Local Port: 01
RX	Indicator	02,69,51,07,00,C1,12,34,56,78,9A,BC,13,03	Rx: Event: ACL Terminated, BdAddr: 123456789ABC, Reason: 13

4.2.3 Acting as Audio Gateway

The audio gateway is defined as a device, handling audio data and using the HS as analog front end for both for input and output. Typical devices acting as Audio Gateways are cellular phones and personal computer. The Simply Blue Module can be used in an audio gateway by creating the required data link to the headset and routing all data from the Advanced Audio Interface (AAI) to the bluetooth link. The audio interface needs to be connected to the host PCM interface. For details on the PCM interface in Simply Blue Module please see [1]. Please see Figure 6 "Headset Data and Audio stream" on page 8 how to implement the Simply Blue Module in a audio gateway application.

The Audio Gateway (AG) controls the inter-operation with the headset in terms of establishing and releasing the required SCO link. While the SPP link establishment can be initiated from both sides, the SCO link establishment will always be initiated by the HSAG. The Simply Blue Module offers dedicated commands to control the audio link.

The necessary configuration can be sum up by the following key points:

- Configure the audio path: Configure the codec and air interface used
- Create a Headset Audio Gateway service record in the Service Database (SDB)
- Adapt the RFCOMM ports to open: Open the port to be in use by the Headset Profile

- Store the Class of Device (COD)

For more information on the detailed procedure, please refer to [1].

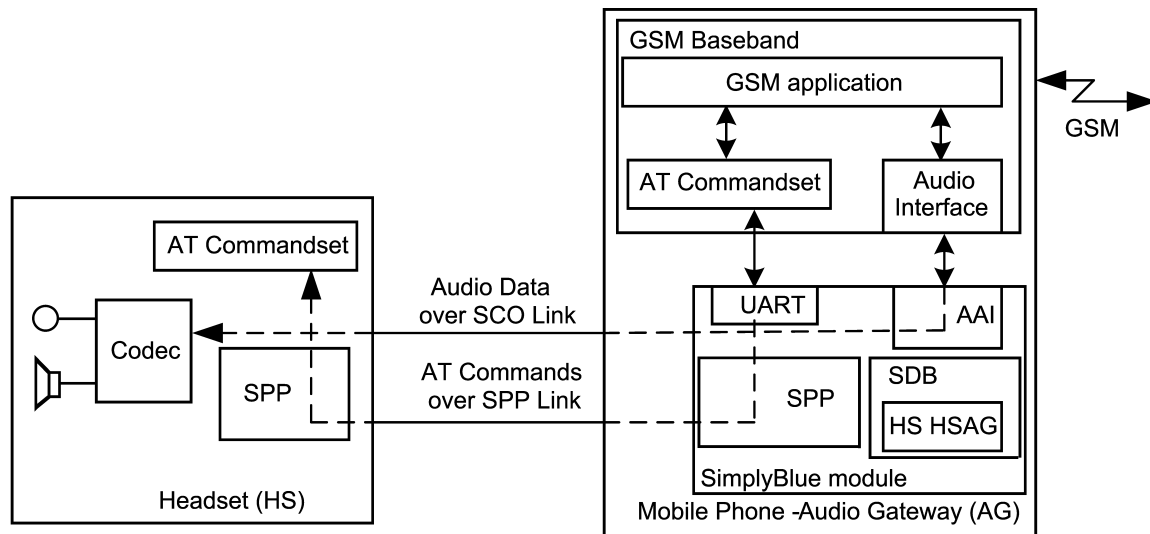

Figure 15. Audio Gateway Data and Audio stream using Simply Blue Module in the HSAG

4.2.3.1 Connection handling as audio gateway

The Headset profile is based on some specific AT commands also listed in Section 5.2 “Headset Profile” on page 24.

In a headset application the link will either be initiated from the HSAG or the HS itself. In both cases the HSAG will control the SCO link establishment. The HS will only react on incoming AT commands and maybe send the request establishment or release.

The Simply Blue Module offers specific commands to establish and release SPP and SCO links. The first connection establishment is based on the standard SPP link. Once this is established the HSAG indicates the incoming call by sending the RING AT command over the SPP link. Once the HS responds with the appropriate AT command, the HSAG needs to establish the SCO connection. In some implementations it is also possible to establish the SCO right after the SPP link to support inband ringtones.

The following chapters give the generic guideline of how to act as HSAG within the different scenarios.

4.2.3.2 Requesting the RFCOMM port from the Headset

An SDAP request is needed to get the RFCOMM port of the remote device. Please refer to the [1] for more details.

4.2.3.3 Outgoing audio connection

Figure 16 on page 16 shows the flow diagram of a HSAG link initiated by the HSAG as defined in [3].

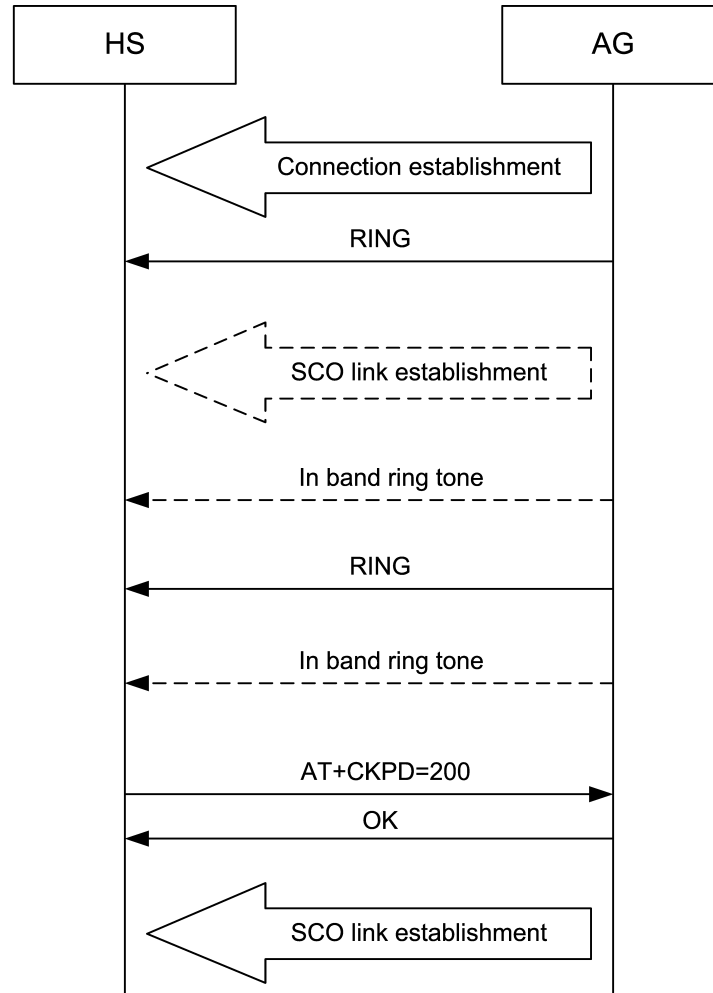
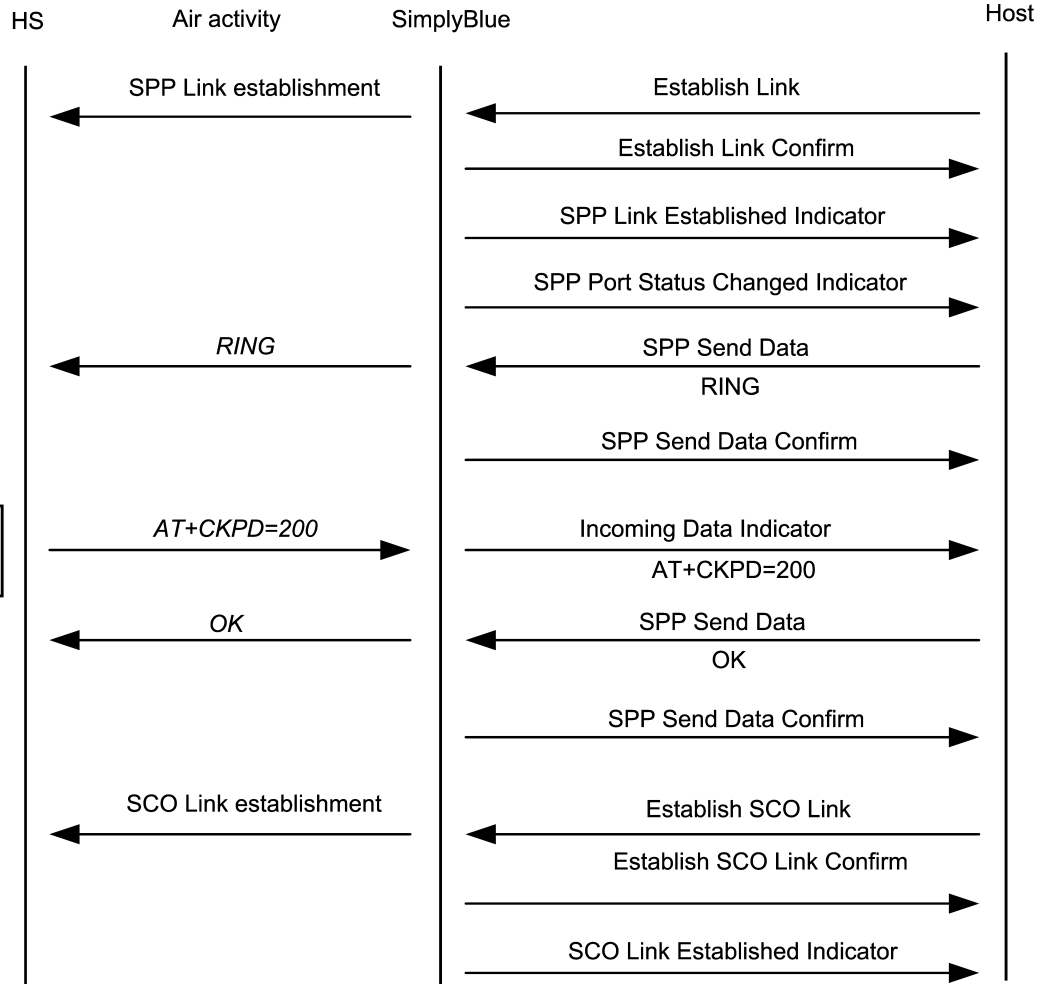

Figure 16. “AG initiated audio connection establishment”

The link is initiated by the HSAG, e.g. in case of an incoming call on a mobile phone. The HSAG will send the “RING” command to force an audio or visual signalling on the headset. The HSAG keeps on ringing until the HS user accepts the incoming link by pressing a button. On this the HS application will send the “AT+CKPD=200” command. The HSAG needs to confirm the successful reception of the command with the “OK” and finally sends the SCO establishment command.

Please see Figure 17 which shows the HSAG part of the profile for the outgoing audio connection ‘translated’ to the Simply Blue Module command interface.



Button Press to accept link

Figure 17. Outgoing audio connection with Simply Blue Module as HSAG

Please see the following table for the detailed description of the UART traffic between host and Simply Blue Module.

Table 7. Outgoing audio connection with Simply Blue Module as HSAG

Direction	What	Hex Code	Interpreted by Simply Blue Commander
TX	Request	02,52,0A,08,00,64,02,12,34,56,78,9A.BC,07,03	Tx: Cmd: Establish Link, Local Port: 02, BdAddr: 123456789ABC, Remote Port Number: 07
RX	Confirm	02,43,0A,02,00,4F,00,02,03	Rx: Event: Establish Link, Status: 00, Local Port: 02
RX	Indicator	02,69,50,07,00,C0,12,34,56,78,9A.BC,00,03	Rx: Event: ACL Established, BdAddr: 123456789ABC, Status: 00
RX	Indicator	02,69,0B,09,00,7D,00,12,34,56,78,9A.BC,02,07,03	Rx: Event: Link Established, Status: 00, BdAddr: 123456789ABC, Local Port: 02, Remote Port Number: 07
RX	Indicator	02,69,3E,04,00,AB,02,8C,00,00,03	Rx: Event: Port Status Changed, Local Port: 02, PortStatus: 8C, Break Length: 0000

Table 7. Outgoing audio connection with Simply Blue Module as HSAG

Direction	What	Hex Code	Interpreted by Simply Blue Commander
TX	Request	02,52,0F,0B,00,6C,02,08,00,0D,0A,52,49,4E,47,0D,0A,03	Tx: Cmd: Send Data, Local Port: 02, Payload Data: 0D0A52494E470D0A (RING)
RX	Confirm	02,43,0F,02,00,54,00,02,03	Rx: Event: Send Data, Status: 00, Local Port: 02
RX	Indicator	02,69,10,0F,00,88,02,0C,00,41,54,2B,43,4B,50,44,3D,32,30,30,0D,03	Rx: Event: Incoming Data, Local Port: 02, Received Data: 41542B434B50443D3230300D (AT+CKPD=200)
TX	Request	02,52,0F,09,00,6A,02,06,00,0D,0A,4F,4B,0D,0A,03	Tx: Cmd: Send Data, Local Port: 02, Payload Data: 0D0A4F4B0D0A (OK)
RX	Confirm	02,43,0F,02,00,54,00,02,03	Rx: Event: Send Data, Status: 00, Local Port: 02
TX	Request	02,52,5D,08,00,B7,12,34,56,78,9A.BC,80,00,03	Tx: Cmd: Establish SCO Link, BdAddr: 123456789ABC, Packet Type: 8000
RX	Confirm	02,43,5D,07,00,A7,00,12,34,56,78,9A.BC,03	Rx: Event: Establish SCO Link, Status: 00, BdAddr: 123456789ABC
RX	Indicator	02,69,5D,07,00,CD,00,12,34,56,78,9A.BC,03	Rx: Event: SCO Link Established, Status: 00, BdAddr: 123456789ABC

In some applications, the headset might send additional commands for volume control or status. Please refer to Section 5.0 on page 23 for the complete list of AT commands required by the headset profile.

4.2.3.4 Incoming audio connection from Headset

The Headset profile also defines the scenario in which the headset initiates the link to the HSAG.

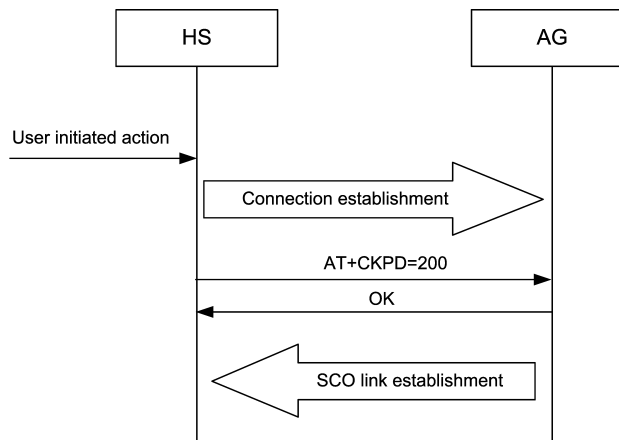

Figure 18. Incoming audio connection on HSAG as defined in [3]

The headset requests a SPP link and sends the AT+CKPD=200 command. The HSAG needs to accept the incoming link and afterwards establish the SCO as already described for an outgoing link.

The headset will contact the HSAG on the RFCOMM port, the HSAG has been assigned to.

Figure 19 and Table 8 show the profile flow necessary to accept an incoming link from a headset using the Simply Blue Module in an HSAG application. The Simply Blue Module in this example is using the default setting, meaning configured for automatic mode. Because of this, it will switch to

transparent mode as soon as the incoming SPP link has been established. Therefore a UART BREAK is sent before the SCO links can be sent.

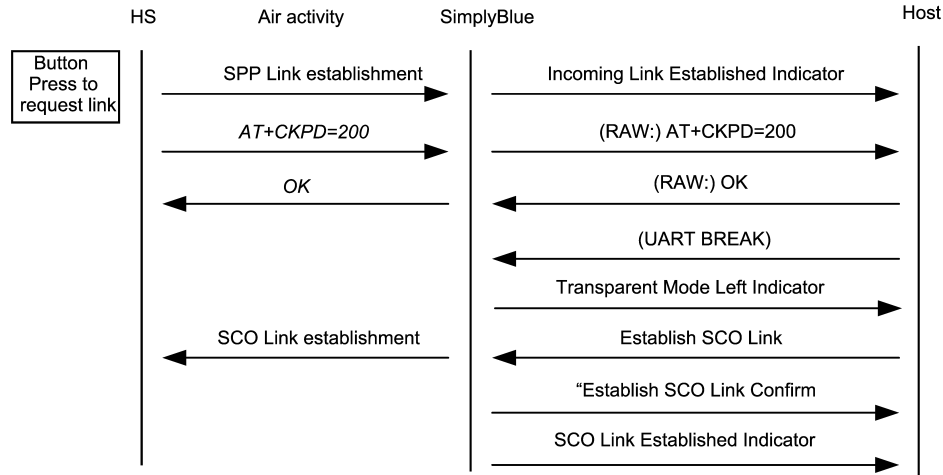

Figure 19. Incoming HS connection as HSAG

Table 8. Incoming headset connection

Direction	What	Hex Code	Interpreted by Simply Blue Commander
TX	Request	02,69,0C,07,00,7C,12,34,56,78,9A,BC,02,03	Rx: Event: Incoming Link Established, BdAddr: 123456789ABC, Local Port: 02
RX	RAW Data	41,54,2B,43,4B,50,44,3D,32,30,30,0D	Rx(RAW): 41,54,2B,43,4B,50,44,3D,32,30,30,0D
TX	RAW Data	0D,0A,4F,4B,0D,0A	Tx(RAW): 0D,0A,4F,4B,0D,0A
TX	UART BREAK		Rx(RAW): 00
RX	Indicator	02,69,11,02,00,7C,02,00,03	Rx: Event: Transparent Mode, Local Port: 02, Mode: 00
TX	Request	02,52,5D,08,00,B7,12,34,56,78,9A,BC,80,00,03	Tx: Cmd: Establish SCO Link, BdAddr: 123456789ABC, Packet Type: 8000
RX	Confirm	02,43,5D,07,00,A7,00,12,34,56,78,9A,BC,03	Rx: Event: Establish SCO Link, Status: 00, BdAddr: 123456789ABC
RX	Indicator	02,69,5D,07,00,CD,00,12,34,56,78,9A,BC,03	Rx: Event: SCO Link Established, Status: 00, BdAddr: 123456789ABC

4.2.3.5 Audio connection release from the HS

The connection release is based on the same command as the connection confirmation, AT+CKPD=200. In case the user wants to release the link from the HS to the HSAG, it presses the same button again, which will send the same AT command. The HSAG will confirm by an OK and release the link.

The Simply Blue Module confirms the released link by the standard “SPP Link Released Indicator”. See following the Bluetooth specification description for the realization with Simply Blue Module. In case the HSAG releases the link the Simply Blue Module will send the same event.

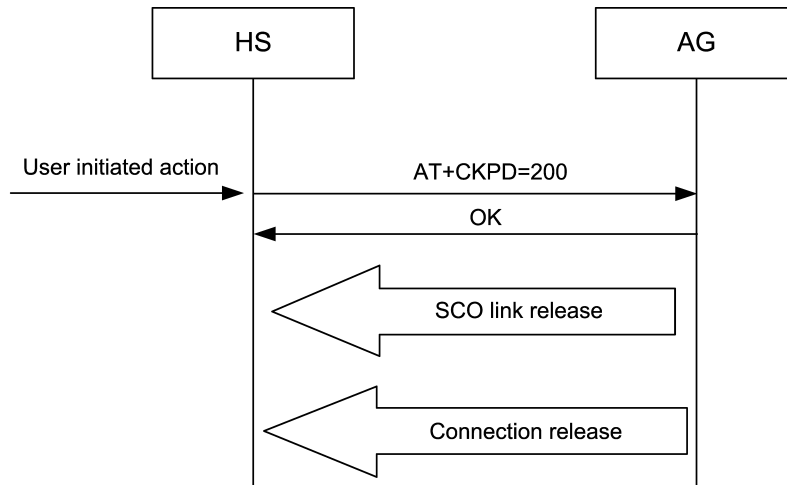

Figure 20. Audio link release by the HS

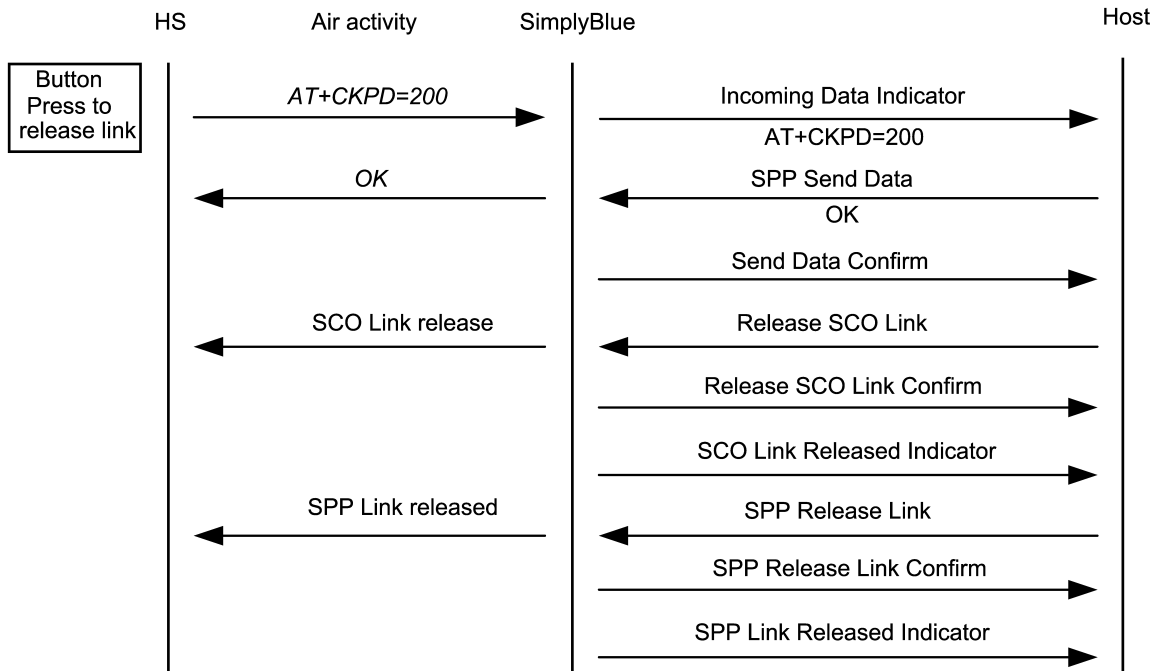

Figure 21. Audio link release by the HS

Table 9. Audio link release by the HS

Direction	What	Hex Code	Interpreted by Simply Blue Commander
RX	Indicator	02,69,10,0F,00,88,02,0C,00,41,54,2B,43,4B,50,44,3D,32,30,30,0D03	Rx: Event: Incoming Data, Local Port: 02, Received Data: 41542B434B50443D3230300D
TX	Request	02,52,0F,09,00,6A,02,06,00,0D,0A,4F,4B,0D,0A,03	Tx: Cmd: Send Data, Local Port: 02, Payload Data: 0D0A4F4B0D0A
RX	Confirm	02,43,0F,02,00,54,00,02,03	Rx: Event: Send Data, Status: 00, Local Port: 02

Table 9. Audio link release by the HS

Direction	What	Hex Code	Interpreted by Simply Blue Commander
TX	Request	02,52,5E,00,00,B0,03	Tx: Cmd: Release SCO Link
RX	Confirm	02,43,5E,01,00,A2,00,03	Rx: Event: Release SCO Link, Status: 00
RX	Indicator	02,69,5E,02,00,C9,00,00,03	Rx: Event: SCO Link Released, Status: 00, HCI Reason: 00
TX	Request	02,52,0D,01,00,60,02,03	Tx: Cmd: Release Link, Local Port: 02
RX	Confirm	02,43,0D,02,00,52,00,02,03	Rx: Event: Release Link, Status: 00, LocalPort: 02
RX	Indicator	02,69,0E,02,00,79,00,02,03	Rx: Event: Link Released, Reason: 00, Local Port: 02
RX	Indicator	02,69,51,07,00,C1,69,9A,01,A4,07,00,16,03	Rx: Event: ACL Terminated, BdAddr: 699A01A40700, Reason: 16

4.2.3.6 Audio connection release initiated by the HSAG

The release of the audio connection uses the standard Simply Blue Module commandset, no further AT command is required.

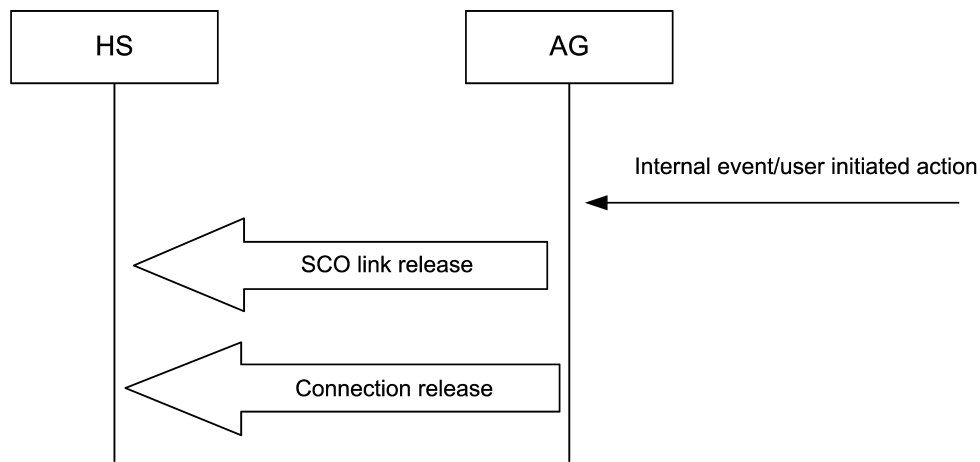

Figure 22. Audio link release initiated by the HSAG

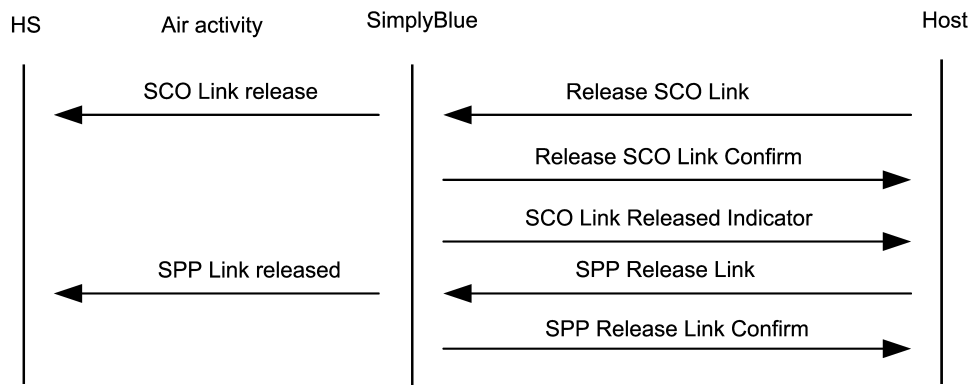

Figure 23. Audio link release initiated by the HSAG

Table 10. Audio connection Release by the AG

Direction	What	Hex Code	Interpreted by Simply Blue Commander
TX	Request	02,52,5E,00,00,B0,03	Tx: Cmd: Release SCO Link
RX	Confirm	02,43,5E,01,00,A2,00,03	Rx: Event: Release SCO Link, Status: 00
RX	Indicator	02,69,5E,02,00,C9,00,00,03	Rx: Event: SCO Link Released, Status: 00, HCI Reason: 00
TX	Request	02,52,0D,01,00,60,02,03	Tx: Cmd: Release Link, Local Port: 02
RX	Confirm	02,43,0D,02,00,52,00,02,03	Rx: Event: Release Link, Status: 00, LocalPort: 02
RX	Indicator	02,69,0E,02,00,79,00,02,03	Rx: Event: Link Released, Reason: 00, Local Port: 02
RX	Indicator	02,69,51,07,00,C1,69,9A,01,A4,07,00,16,03	Rx: Event: ACL Terminated, BdAddr: 699A01A40700, Reason: 16

5.0 AT Commands

The list of AT Commands is derived out of the "Bluetooth Profiles Book V1.1" from the Bluetooth SIG. All commands shall be implemented as described in International Telecommunication Union, "ITU-T Recommendation V.250"

5.1 DUN GW

5.1.1 Required commands

Table 11. Required AT Commands for DUN GW

Name	Description
&C	Circuit 109 (Received line signal detector) Behavior
&D	Circuit 108 (Data terminal ready) Behavior
&F	Set to Factory-defined Configuration
+GCAP	Request Complete Capabilities List
+GMI	Request Manufacturer Identification
+GMM	Request Model Identification
+GMR	Request Revision Identification
A	Answer
D	Dial
E	Command Echo
H	Hook Control
L	Monitor Speaker Loudness
M	Monitor Speaker Mode
O	Return to Online Data State
P	Select Pulse Dialling
Q	Result Code Suppression
S0	Automatic Answer
S10	Automatic Disconnect Delay
S3	Command Line Termination Character
S4	Response Formatting Character
S5	Command Line Editing Character
S6	Pause Before Blind Dialling
S7	Connection Completion Timeout
S8	Comma Dial Modifier Time
T	Select Tone Dialling
V	DCE Response Format
X	Result Code Selection and Call Progress Monitoring Control
Z	Reset To Default Configuration

5.1.2 Required Result Codes

Table 12. Result Codes for DUN

Name	Description
&C	Circuit 109 (Received line signal detector) Behavior
OK	Acknowledges execution of a command.
CONNECT	Connection has been established.
RING	The DCE has detected an incoming call signal from the network.
NO CARRIER	The connection has been terminated, or the attempt to establish a connection failed.
ERROR	Error.
NO DIALTONE	No dial-tone detected.
BUSY	Busy signal detected.

5.2 HEADSET PROFILE

The following AT commands are defined for the headset profile.

5.2.1 Headset AT Command

Table 13. AT Commands for Headset profile

AT Capability	Syntax	Description	Values
RING		The Incoming call indication of ITU V.250, Section 6.3.4	
Microphone gain	+VGM=<gain>	Unsolicited result code issued by the HSAG to set the microphone gain of the HS. <gain> is a decimal numeric constant, relating to a particular (implementation-dependent) volume level controlled by the HS.	<gain>: 0-15
Speaker gain	+VGS=<gain>	Unsolicited result code issued by the HSAG to set the speaker gain of the HS. <gain> is a decimal numeric constant, relating to a particular (implementation-dependent) volume level controlled by the HS.	<gain>: 0-15
Microphone gain level report	+VGM=<gain>	Command issued by the HS to report the current microphone gain level setting to the HSAG. <gain> is a decimal numeric constant, relating to a particular (implementation-dependent) volume level controlled by the HS	<gain>: 0-15
Speaker gain level indication report	+VGS=<gain>	Command issued by the HS to report the current speaker gain level setting to the HSAG. <gain> is a decimal numeric constant, relating to a particular (implementation-dependent) volume level controlled by the HS	<gain>: 0-15
Headset button press	+CKPD=200	Command issued by the HS to indicate that the button has been pressed.	

5.2.2 Required Result Codes

Table 14. Required result codes for Headset implementations

Name	Description
OK	Acknowledges execution of a command.
RING	The DCE has detected an incoming call signal from the network.
ERROR	Error.

6.0 Bibliography

- [1] AN-1699: LMX9838 Software User's Guide
- [2] Bluetooth SIG: Specification of the Bluetooth System 1.2, November 05 2003
- [3] Bluetooth SIG: Specification of the Bluetooth System 1.1, Volume 2 / Profiles, Version 1.1, February 22 2001
- [4] Bluetooth SIG: Bluetooth Assigned Numbers, https://www.bluetooth.org/foundry/assignnumb/document/assigned_numbers

NOTES

THE CONTENTS OF THIS DOCUMENT ARE PROVIDED IN CONNECTION WITH NATIONAL SEMICONDUCTOR CORPORATION ("NATIONAL") PRODUCTS. NATIONAL MAKES NO REPRESENTATIONS OR WARRANTIES WITH RESPECT TO THE ACCURACY OR COMPLETENESS OF THE CONTENTS OF THIS PUBLICATION AND RESERVES THE RIGHT TO MAKE CHANGES TO SPECIFICATIONS AND PRODUCT DESCRIPTIONS AT ANY TIME WITHOUT NOTICE. NO LICENSE, WHETHER EXPRESS, IMPLIED, ARISING BY ESTOPPEL OR OTHERWISE, TO ANY INTELLECTUAL PROPERTY RIGHTS IS GRANTED BY THIS DOCUMENT.

TESTING AND OTHER QUALITY CONTROLS ARE USED TO THE EXTENT NATIONAL DEEMS NECESSARY TO SUPPORT NATIONAL'S PRODUCT WARRANTY. EXCEPT WHERE MANDATED BY GOVERNMENT REQUIREMENTS, TESTING OF ALL PARAMETERS OF EACH PRODUCT IS NOT NECESSARILY PERFORMED. NATIONAL ASSUMES NO LIABILITY FOR APPLICATIONS ASSISTANCE OR BUYER PRODUCT DESIGN. BUYERS ARE RESPONSIBLE FOR THEIR PRODUCTS AND APPLICATIONS USING NATIONAL COMPONENTS. PRIOR TO USING OR DISTRIBUTING ANY PRODUCTS THAT INCLUDE NATIONAL COMPONENTS, BUYERS SHOULD PROVIDE ADEQUATE DESIGN, TESTING AND OPERATING SAFEGUARDS.

EXCEPT AS PROVIDED IN NATIONAL'S TERMS AND CONDITIONS OF SALE FOR SUCH PRODUCTS, NATIONAL ASSUMES NO LIABILITY WHATSOEVER, AND NATIONAL DISCLAIMS ANY EXPRESS OR IMPLIED WARRANTY RELATING TO THE SALE AND/OR USE OF NATIONAL PRODUCTS INCLUDING LIABILITY OR WARRANTIES RELATING TO FITNESS FOR A PARTICULAR PURPOSE, MERCHANTABILITY, OR INFRINGEMENT OF ANY PATENT, COPYRIGHT OR OTHER INTELLECTUAL PROPERTY RIGHT.

LIFE SUPPORT POLICY

NATIONAL'S PRODUCTS ARE NOT AUTHORIZED FOR USE AS CRITICAL COMPONENTS IN LIFE SUPPORT DEVICES OR SYSTEMS WITHOUT THE EXPRESS WRITTEN APPROVAL OF THE PRESIDENT AND GENERAL COUNSEL OF NATIONAL SEMICONDUCTOR CORPORATION. As used herein:

Life support devices or systems are devices which (a) are intended for surgical implant into the body, or (b) support or sustain life and whose failure to perform when properly used in accordance with instructions for use provided in the labeling can be reasonably expected to result in a significant injury to the user. A critical component is any component in a life support device or system whose failure to perform can be reasonably expected to cause the failure of the life support device or system or to affect its safety or effectiveness.

National Semiconductor and the National Semiconductor logo are registered trademarks of National Semiconductor Corporation. All other brand or product names may be trademarks or registered trademarks of their respective holders.

Copyright© 2007 National Semiconductor Corporation

For the most current product information visit us at www.national.com



**National Semiconductor
Americas Customer
Support Center**
Email:
new.feedback@nsc.com
Tel: 1-800-272-9959

**National Semiconductor Europe
Customer Support Center**
Fax: +49 (0) 180-530-85-86
Email: europe.support@nsc.com
Deutsch Tel: +49 (0) 69 9508 6208
English Tel: +49 (0) 870 24 0 2171
Français Tel: +33 (0) 1 41 91 8790

**National Semiconductor Asia
Pacific Customer Support Center**
Email: ap.support@nsc.com

**National Semiconductor Japan
Customer Support Center**
Fax: 81-3-5639-7507
Email: jpn.feedback@nsc.com
Tel: 81-3-5639-7560