

## DP83848K-MAU-EK Purpose and Contents

The purpose of the DP83848K-MAU-EK (EK) is to provide National Semiconductor Corp.'s customers with a vehicle to quickly design and market systems containing the DP83848K chip. Customers are encouraged to copy EK components to expedite their design process.

The EK contains:

- DP83848K Media Attachment Unit (MAU)
- Printed copy of this User's Guide
- DP83848K MAU schematic
- DP83848K MAU licensing agreement

## Information and Specifications

This section contains specifications of the DP83848K MAU card, as well as a description of the card's interfaces, connectors, jumpers and the LED.

### Usage setup and configuration

- 3.3V power for the DP83848K MAU may be supplied via MII connector. If 3.3V is supplied from the MII connector, R32 needs to be stuffed (See schematics for details)
  - R33 and R34 should be stuffed for MDIO connection only if 3.3V MII is used
- External 3.3V power is supplied for the DP83848K MAU, if 5V is supplied from the MII connector, R32 should not be stuffed in this case (See schematics for details)
- To set Auto-MDIX ON, do not stuff resistor R30. To set Auto-MDIX OFF, stuff resistor R30 (See schematics for details)
- To configure LED in mode1 for link, do not stuff resistor R31. To configure LED for link and activity, stuff resistor R31 (See schematics for details)
- If the DP83848K MAU card is used for a PHYTERMini device – DP83848M/T/H, remove resistor R42 (See schematics for details)

### Address settings

The PMD address for the DP83848K Physical Layer device is set by resistor R29.

- Default board setting for the PHY Address is 01 (Do not stuff resistor R29)
- The board may be set to PHY Address 03 by stuffing resistor R29.

### Table of jumpers

Jumper	Name	Function
J1	MIII Male Connector	MIII interface
J10	External power supply	External 3.3V power is supplied for the DP83848K MAU via jumper J10. R32 should not be stuffed in this case
J13	Pulse Jack	Integrated Magnetic RJ-45 connector
J15	MDIO connector	Connection to the parallel port using Integrity version 3.24 or higher (See Figure below for parallel port to MDIO/MDC connection)

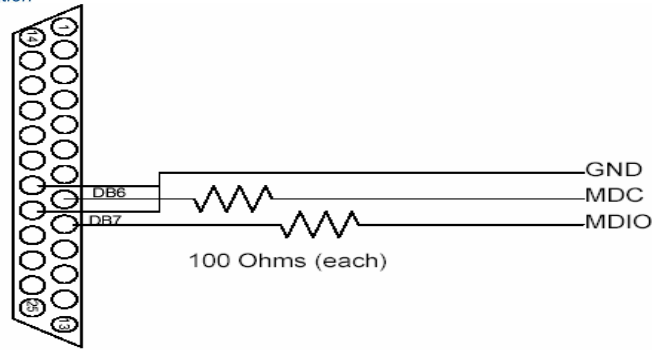

**Integrity V3.24 Direct connect cable map**

## DP83848K MAU Specification

### Overview

The DP83848K MAU is an NSC demo platform to allow customer evaluation of our device. While the DP83848K has many advanced and enticing features, this specific board is designed to demonstrate *only* a subset of those. The features chosen are the ones that the mainstream customers will use. Thus, we have created an affordable, aesthetic platform to demonstrate the simplicity of designing in a National Semiconductor DP83848K.

### Target Environment

Any customer equipment that provides a standard IEEE 802.3, Clause 22 MII DTE interface; e.g. SmartBits/Netcom box.

### Features/Goals

The DP83848K MAU features:

- Integrated magnetics
- Minimum configuration requirements:
  - 2 PHY Addresses - 01h (default) or 03h
  - 2 LEDs – 1 LED for LINK and 1 LED for SPEED
  - Strap Options – MDIX\_EN, LED\_CFG
- Connections for the following interfaces:
  - MII Interface
  - Integrated transformer RJ-45
- Standard PCB layout considerations with regards to clock, MII, and TD/RD
- Double sided component placement
- On-board clock – Crystal
- On-board power supplied by MII connector, External 3.3V supplied via jumper
- Compact board and Low cost

## MAU Block Diagram

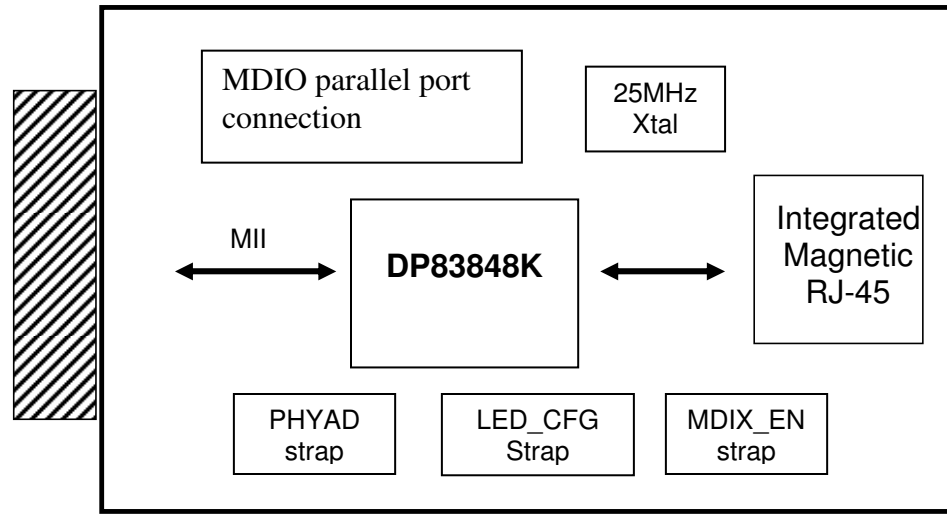

### PCB Physical Layout requirements / Considerations

- FR4 material
- Trace impedance will be ensured by design:
  - Trace symmetry within differential pair (+/- 0.5")
  - Differential impedance 100 ohms, +/- 5%
  - Adjacent differential pairs spacing > 2X distance within a differential pair, to minimize cross-talk and EMI
- Trace length matching between differential pairs not required
- Trace space will be 0.007"/0.008" minimum
- Uniform supply & ground plane
- Combination of through-hole and surface mount technology
- Target size 2.05" (height), 1.5" (length)
- 4 layers
- Silk screen on two sides

### MAU Interface requirements

- System interface will be via the MII connector, and MII header
- RJ-45 for network connection

### Software

- No device specific software is required for this board  
National does provide the integrity utility; a diagnostic and configuration package at [www.national.com/appinfo/networks/ethernet\\_utility.html](http://www.national.com/appinfo/networks/ethernet_utility.html)

### Additional information

Updated versions of the included material, related material can be found by going to [ethernet.national.com](http://ethernet.national.com) or directly to design resources at <http://www.national.com/appinfo/networks/webench/dp83848.html>



**National Semiconductor Corporation**

2900 Semiconductor Drive  
Santa Clara, CA 95051, U.S.A.

Tel: 1-800-272-9959

Fax: 1-800-737-7018

Email: support@nsc.com

WWW: www.national.com

**National Semiconductor Europe**

Fax: (+49) 0-180-530 85 86

Email: europe.support@nsc.com

Deutsch Tel: (+49) 0-180-530 85 85

English Tel: (+49) 0-180-532 78 32

**National Semiconductor Asia Pacific**

**Customer Response Group**

Tel: 65-254-4466

Fax: 65-250-4466

Email: sea.support@nsc.com

**National Semiconductor Japan Ltd.**

Tel: 81-3-5620-6175

Fax: 81-3-5620-6179

Copyright © 2005 National Semiconductor Corporation.

National Semiconductor and the National Semiconductor logo are registered trademarks of National Semiconductor Corporation.  
All other brand or product names are trademarks of their respective holders.