

ADC16DV160HFEB

Evaluation Board User's Guide

ADC16DV160 Dual 16-Bit, 160 MSPS A/D Converter

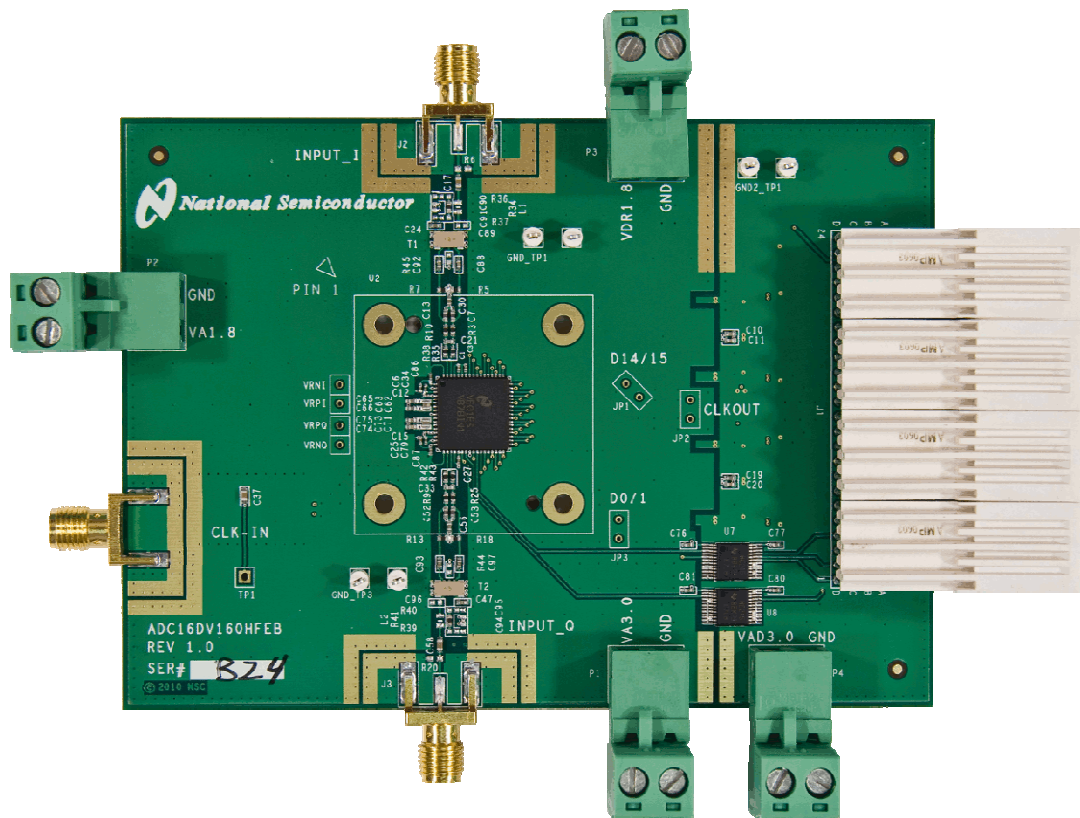

Table of Contents

1.0 Introduction	3
2.0 Board Assembly.....	3
3.0 Quick Start.....	4
4.0 Functional Description.....	4
4.1 Analog Input.....	4
4.2 ADC reference circuitry	4
4.3 ADC clock circuit.....	5
4.4 Power Supply Connections.....	5
5.0 Installing the ADC16DV160 Evaluation Board	5
6.0 Hardware Schematic	6
7.0 Evaluation Board Layout	7
8.0 Evaluation Board Bill of Materials.....	10

1.0 Introduction

This Evaluation Board may be used to evaluate the ADC16DV160. The ADC is a dual 16 bit analog to digital converters that provides data at rates of up to 160 MHz.

The evaluation board is designed to be used with the WaveVision5™ Data Capture Board which is connected to a personal computer through a USB port and running WaveVision5™ software, operating under Microsoft Windows. The software can perform an FFT on the captured data upon command and, in addition to a frequency domain plot, shows dynamic performance in

the form of SNR, SINAD, THD SFDR and ENOB. The latest WaveVision software is available through the National Semiconductor website:
<http://www.national.com/analog/adc/wavevision5>

2.0 Board Assembly

The ADC16DV160 Evaluation Board comes pre-assembled. Refer to the Bill of Materials in *Section 8* for a description of components, to *Figure 1* for major component placement and to *Section 6* for the Evaluation Board schematic.

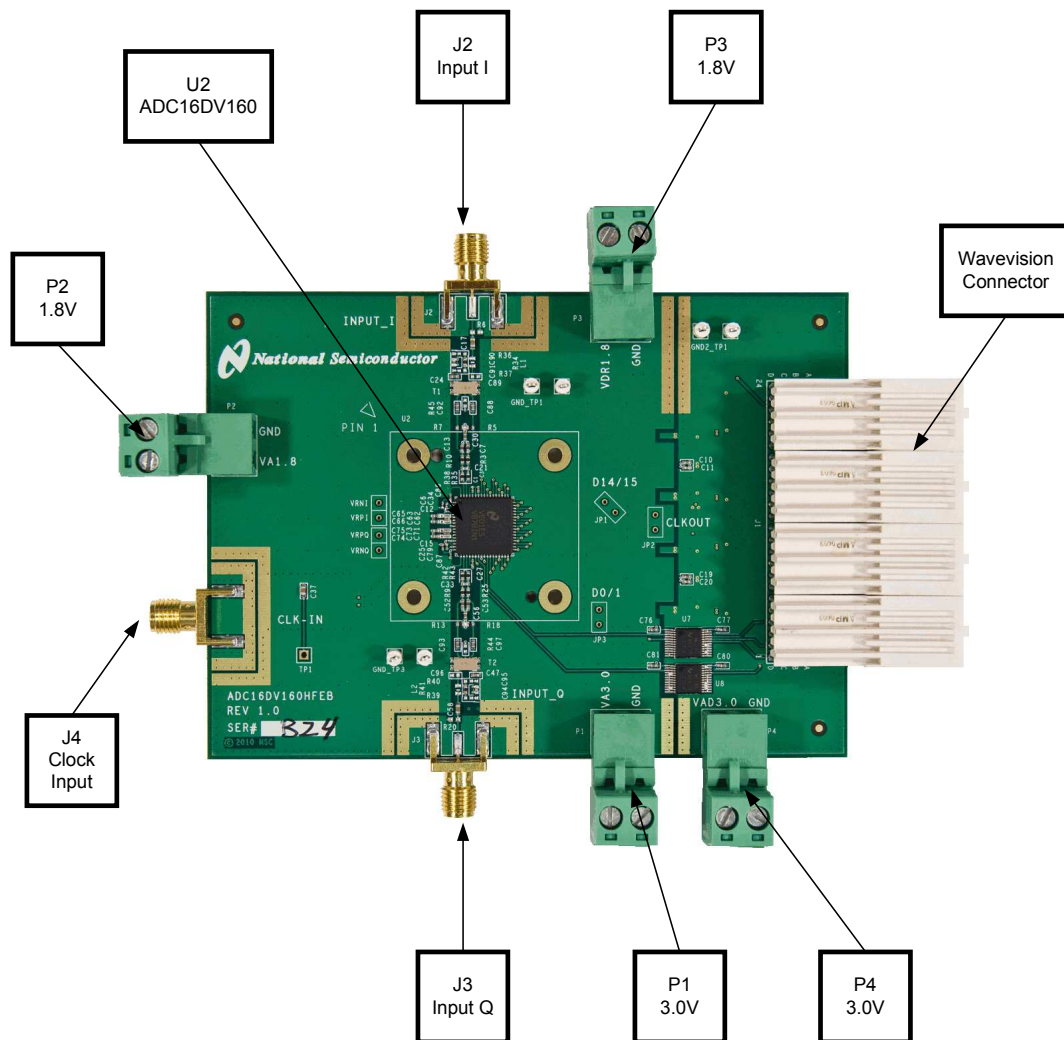

Figure 1. Major Component Locations

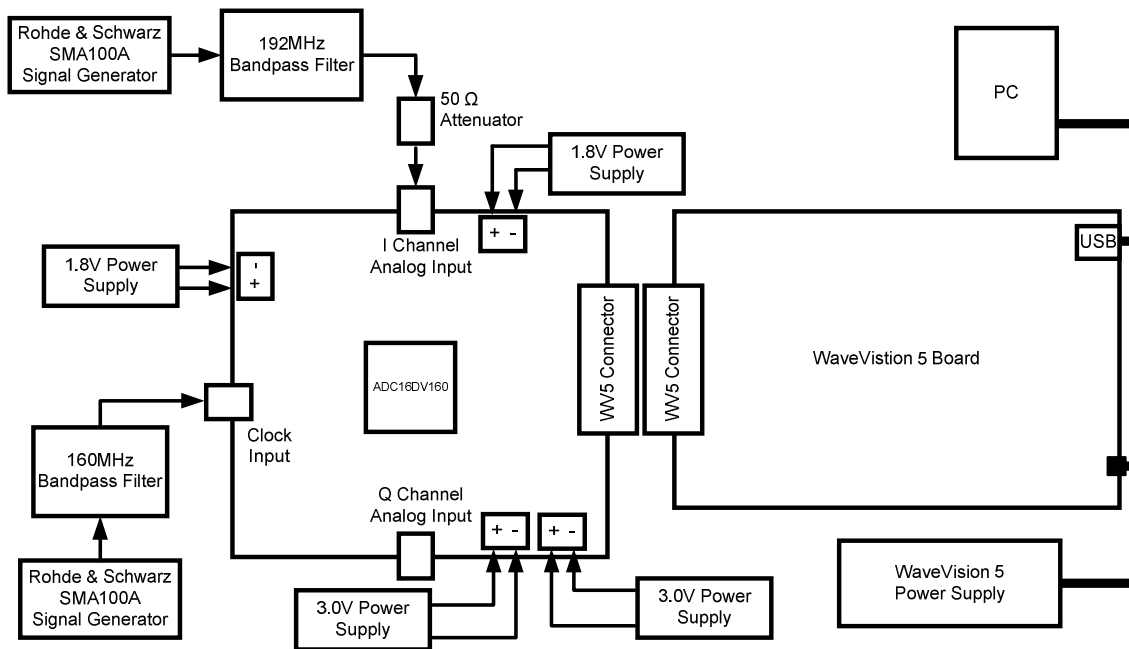

Figure 2: Test Set Up

3.0 Quick Start

Refer to *Figure 1* for locations of jumpers, test points and major components. Refer to *Figure 2* for the test set up.

The latest WaveVision software is available through the National Semiconductor website:
<http://www.national.com/analog/adc/wavevision5>.

If a software CD is included with the evaluation board kit, then use the provided software and instructions to install WaveVision and ensure compatibility with this evaluation board.

1. Apply power to the WaveVision5™ board and connect it to the computer using a USB cable. See the WaveVision5™ User Guide for operation of that board. Connect the evaluation board to the WaveVision5™ Data Capture Board. **NOTE: power to the WaveVision5 Data Capture Board should be applied before power to the ADC16DV160 Evaluation Board to insure that the FPGA on the WaveVision5 Data Capture Board is not damaged.**
2. Connect a clean +3.0V power supply to Power Connectors P1 and P4. Connect a clean +1.8V power supply to Power Connectors P2 and P3.
3. Connect a 160 MHz signal from a 50-Ohm source to connector J4 for the input Clock. Be sure to use a

bandpass filter before the Evaluation Board. Set the amplitude to 18 dBm.

4. Connect a signal from a 50-Ohm source to connector J2 (I Channel) or J3 (Q-Channel). Be sure to use a bandpass filter before the Evaluation Board. For best results, also attach a 3dB 50 ohm attenuator right at the input SMA of the eval board. This will help match the impedance between the cables/signal source to the eval board input.
5. Adjust the input signal amplitude as needed to ensure that the signal does not over-range by examining a histogram of the output data with the WaveVision™ software.

4.0 Functional Description

The ADC16DV160 Evaluation Board schematic is shown in *Section 6*. A list of test points and jumper settings can be found in the Appendix.

4.1 Analog Input

To obtain the best distortion results the analog input network must be optimized for the signal frequency being applied. The ADC16DV160 Evaluation Board comes configured for input frequencies greater than 70MHz. To accurately evaluate the dynamic performance of this converter, the input test signal will have to be passed through a high-quality bandpass filter.

4.2 ADC reference circuitry

This Evaluation Board is configured to use the internal reference.

4.3 ADC clock circuit

Care must be taken to provide a high quality low jitter clock source. The board is configured to accept a single ended sinusoidal. It converts the sine wave to a differential signal through transformer T4. Refer to the schematic for more detail.

4.4 Power Supply Connections

Power is applied to the board through power connectors P1 – P4. Care must be taken to observe the correct polarity.

5.0 Installing the ADC16DV160 Evaluation Board

The evaluation board requires a dual power supplies as described in *Section 4.4*. **NOTE: power to the WaveVision5 Data Capture Board should be applied before power to the ADC16DV160 Evaluation Board to insure that the FPGA on the WaveVision5 Data Capture Board is not damaged.** A low noise sinusoidal signal source should be connected to the Clock Input SMA connector J4. An appropriate signal source should be connected to the Signal Input SMA connector J2. When evaluating dynamic performance, an appropriate signal generator (such as R&S SMA-100A) with 50 Ohm source impedance should be connected to the Analog Input connector through an appropriate bandpass filter as even the best signal generator available can not produce a signal pure enough to evaluate the dynamic performance of an ADC.

If this board is used in conjunction with the the WaveVision5™ Data Capture Board and WaveVision5™ software, a USB cable must be connected between the Data Capture Board and the host. See the WaveVision5™ Data Capture Board manual for details.

6.0 Hardware Schematic

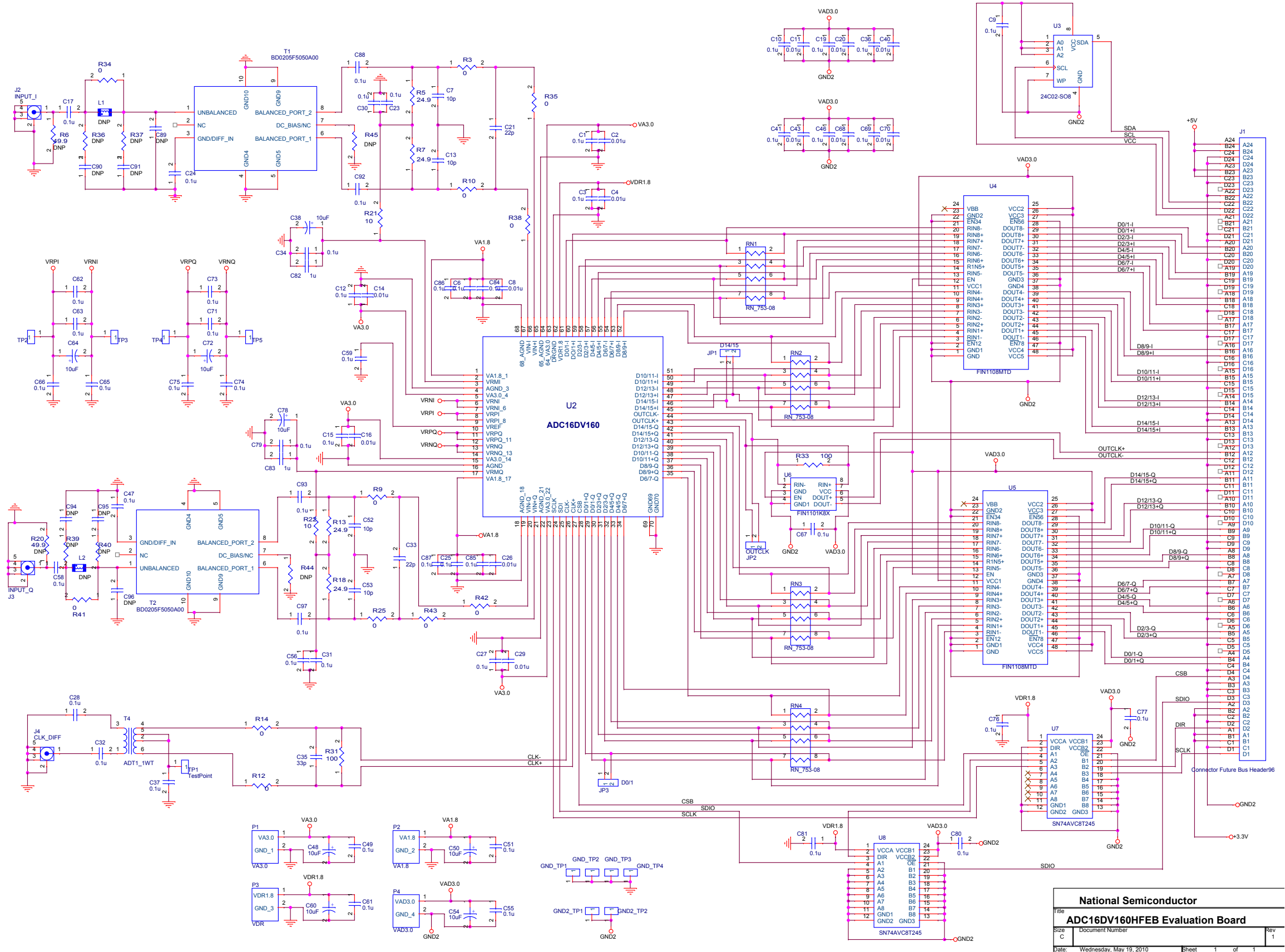

National Semiconductor			
ADC16DV160HFEB Evaluation Board			
Title	Document Number	Rev 1	
Size	C	1	
Date:	Wednesday, May 19, 2010	Sheet	1 of 1

7.0 Evaluation Board Layout

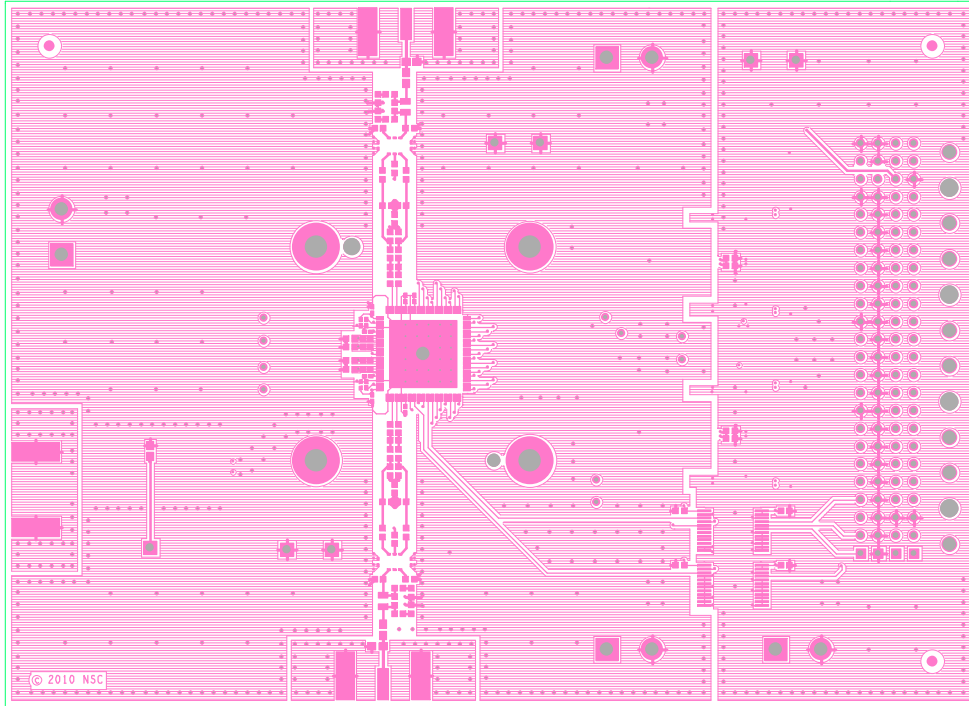

Layer 1: Component Side

NATIONAL SEMICONDUCTOR	
DESCRIPTION A:	
DESCRIPTION B:	
BOARD LAYER:	L1 TOP SIDE
FILE:	ADC16DV160HFEB.b
DATE:	05/07/201
BY:	ERIC MASSE

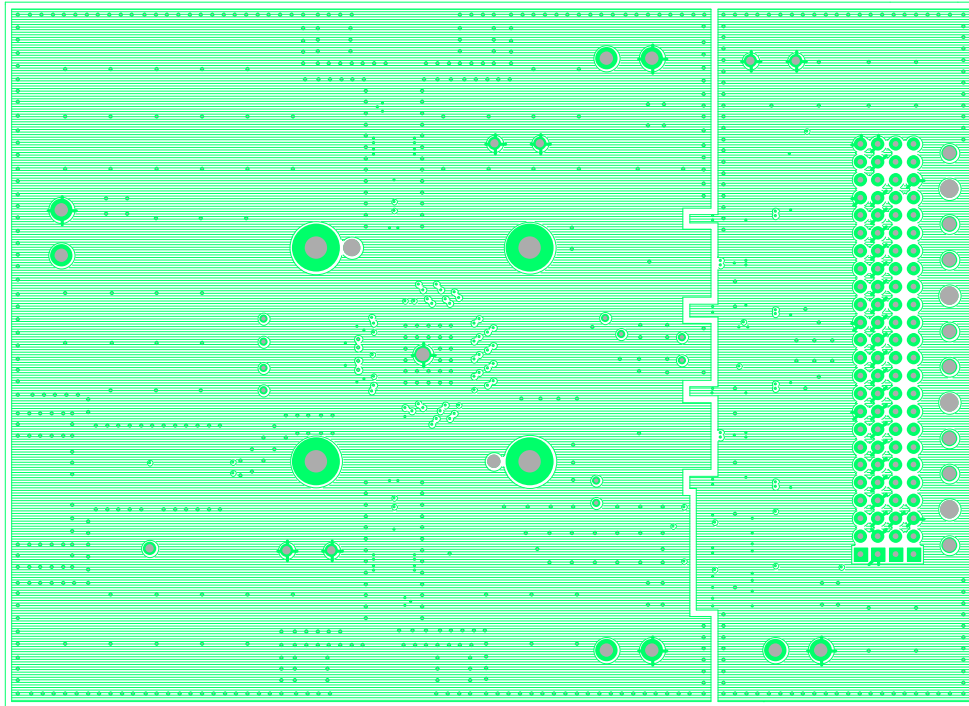

Layer 2: Ground

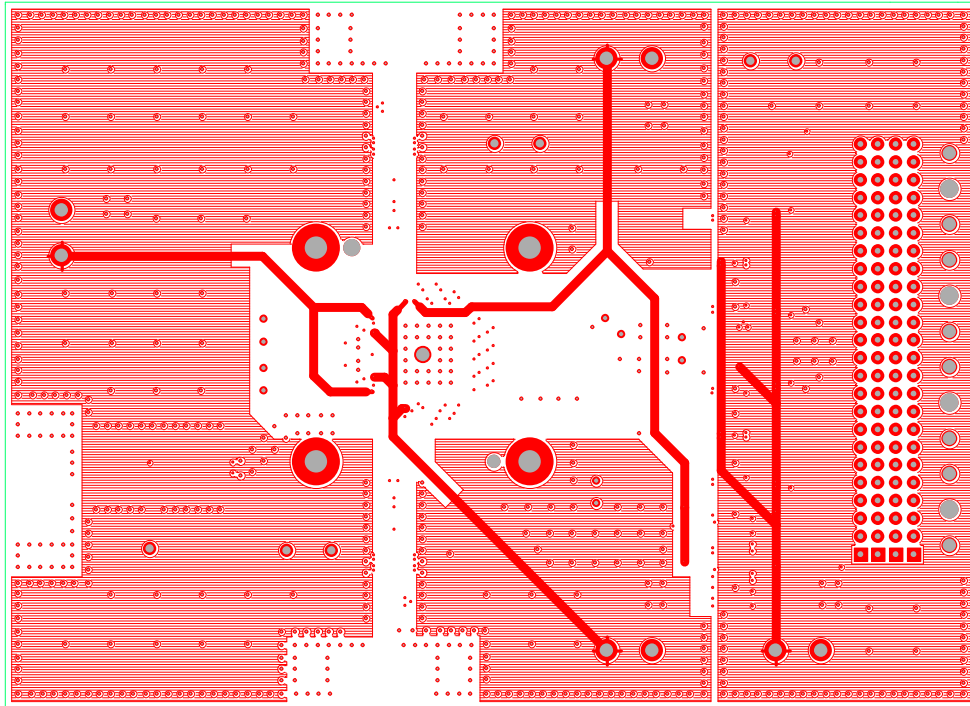

Layer 3: Power

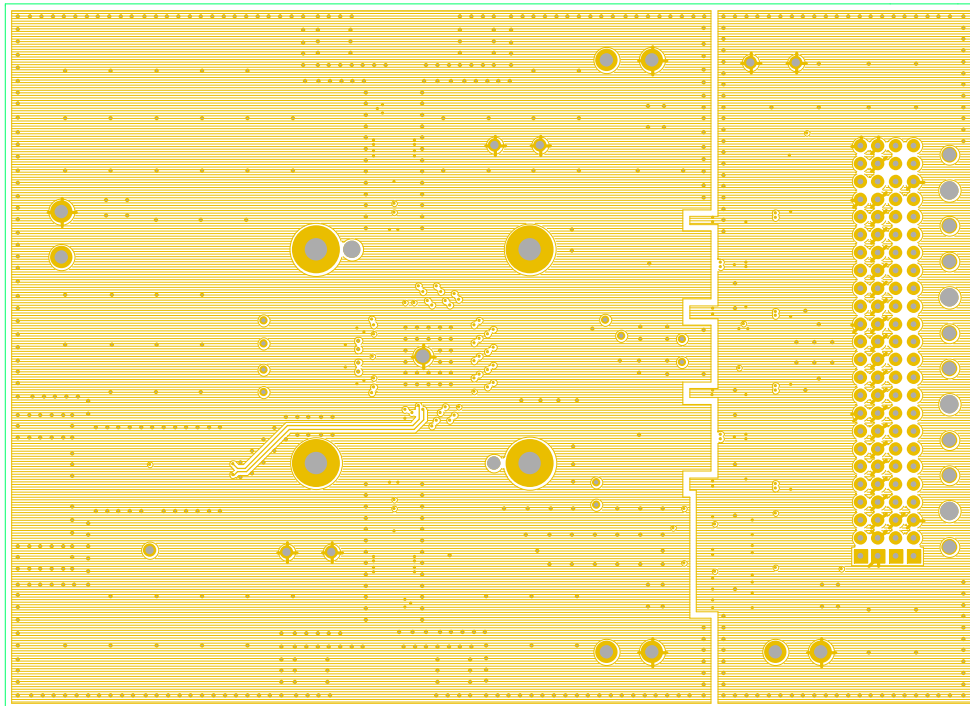

Layer 4: Ground, Clock

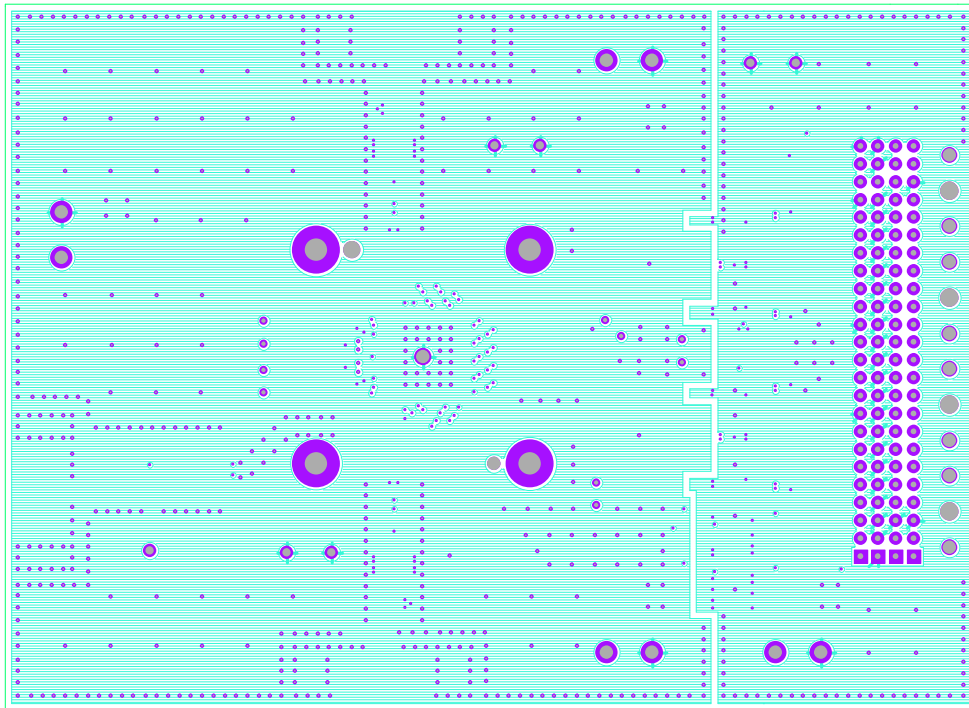

Layer 5: Ground

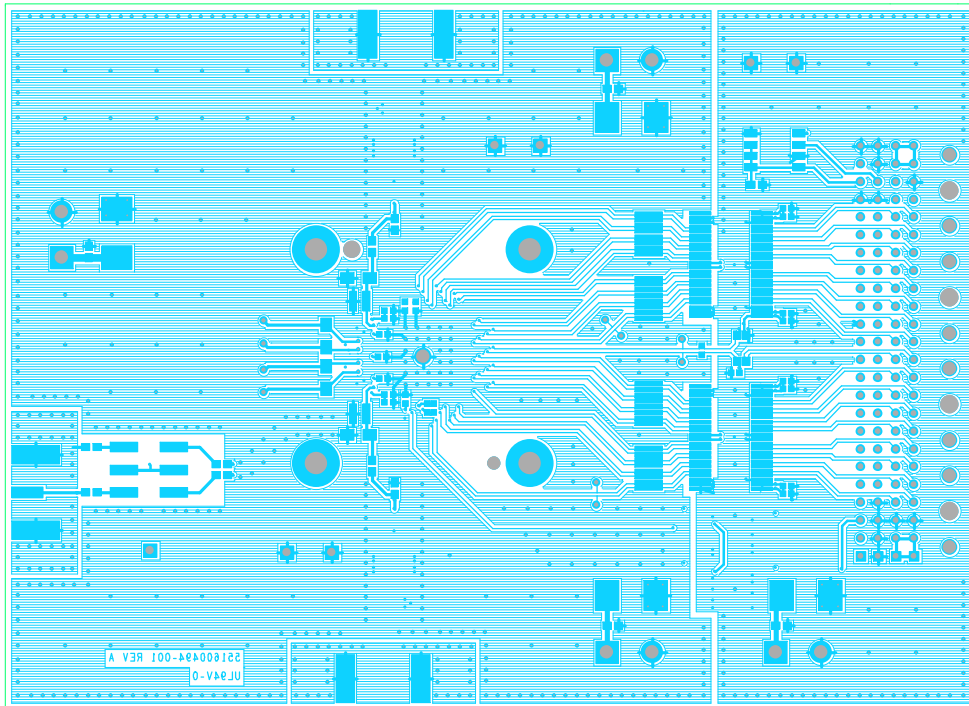

Layer 6: Circuit Side

8.0 Evaluation Board Bill of Materials

Item	Quantity	Reference	Part	Manufacturer	Manufacturer P/N
1	11	C1,C3,C6,C12,C15,C25,C27, C34,C79,C86,C87	0.1u	Murata	GRM033R60J104KE19D
2	13	C2,C4,C8,C11,C14,C16,C20, C26,C29,C40,C43,C68,C70	0.01u	Murata	GRM155R71H103KA88D
3	4	C7,C13,C52,C53	10p	Murata	GRM1555C1H100JZ01D
4	12	C9,C17,C23,C28,C31,C32, C37,C49,C51,C55,C58,C61	0.1u	Murata	GRM188R71C104KA01D
5	30	C10,C19,C24,C30,C36,C41, C46,C47,C56,C59,C62,C63, C65,C66,C67,C69,C71,C73, C74,C75,C76,C77,C80,C81, C84,C85,C88,C92,C93,C97	0.1u	Murata	GRM155R61A104KA01D
6	2	C21,C33	22p	Murata	GRM1555C1H220JZ01D
7	1	C35	33p	Murata	GRM1555C1H330JZ01D
8	4	C38,C64,C72,C78	10uF	Nichicon	F931A106MAA
9	4	C48,C50,C54,C60	10uF	AVX	TAJC106K020R
10	2	C82,C83	1u	Panasonic	ECY-29RA105KV
13	6	GND_TP1,GND_TP2,GND_TP3, GND_TP4,GND2_TP1, GND2_TP2	TestPoint	Keystone	5002
17	1	NSC J1	Connector Future Bus Header96	Tyco Electronics	5223514-3
18	1	J2	INPUT_I	Johnson	142-0701-851
19	1	J3	INPUT_Q	Johnson	142-0701-851
20	1	J4	CLK_DIFF	Johnson	142-0701-851
22	1	P1	VA3.0	Phoenix Contacts	1759017
23	1	P2	VA1.8	Phoenix Contacts	1759017
24	1	P3	VDR	Phoenix Contacts	1759017
25	1	P4	VAD3.0	Phoenix Contacts	1759017
26	4	RN1,RN2,RN3,RN4	RN_753-08	CTS Resistor	753083101GTR
27	10	R3,R9,R10,R25,R34,R35, R38,R41,R42,R43	0	Yageo	RC0402JR-070RL
28	4	R5,R7,R13,R18	24.9	Panasonic - ECG	ERJ-2RKF24R9X
30	2	R12,R14	0	Yageo	RC0603JR-070RL
31	2	R21,R22	10	Panasonic - ECG	ERJ-3EKF10ROV
32	2	R31,R33	100	Panasonic - ECG	ERJ-2RKF1000X
37	2	NSC T1,T2	BD0205F5050A00	Anaren	BD0205F5050A00
38	1	T4	ADT1_1WT	Mini-Circuits	ADT1-1WT+
39	1	NSC U2	ADC16DV160	National Semiconductor	ADC16DV160
40	1	U3	24C02-SO8	Atmel	AT24HC02BN-SH-B
41	2	U4,U5	FIN1108MTD	Fairchild	FIN1108MTD
42	1	U6	FIN1101K8X	Fairchild	FIN1101K8X
43	2	U7,U8	SN74AVC8T245	Texas Instruments	SN74AVC8T245DGVR

BY USING THIS PRODUCT, YOU ARE AGREEING TO BE BOUND BY THE TERMS AND CONDITIONS OF NATIONAL SEMICONDUCTOR'S END USER LICENSE AGREEMENT. DO NOT USE THIS PRODUCT UNTIL YOU HAVE READ AND AGREED TO THE TERMS AND CONDITIONS OF THAT AGREEMENT. IF YOU DO NOT AGREE WITH THEM, CONTACT THE VENDOR WITHIN TEN (10) DAYS OF RECEIPT FOR INSTRUCTIONS ON RETURN OF THE UNUSED PRODUCT FOR A REFUND OF THE PURCHASE PRICE PAID, IF ANY.

The ADC16DV160 Evaluation Boards are intended for product evaluation purposes only and are not intended for resale to end consumers, is not authorized for such use and is not designed for compliance with European EMC Directive 89/336/EEC, or for compliance with any other electromagnetic compatibility requirements.

National Semiconductor Corporation does not assume any responsibility for use of any circuitry or software supplied or described. No circuit patent licenses are implied.

LIFE SUPPORT POLICY

NATIONAL'S PRODUCTS ARE NOT AUTHORIZED FOR USE AS CRITICAL COMPONENTS IN LIFE SUPPORT DEVICES OR SYSTEMS WITHOUT THE EXPRESS WRITTEN APPROVAL OF THE PRESIDENT OF NATIONAL SEMICONDUCTOR CORPORATION. As used herein:

1. Life support devices or systems are devices or systems which, (a) are intended for surgical implant into the body, or (b) support or sustain life, and whose failure to perform, when properly used in accordance with instructions for use provided in the labeling, can be reasonably expected to result in a significant injury to the user.
2. A critical component is any component in a life support device or system whose failure to perform can be reasonably expected to cause the failure of the life support device or system, or to affect its safety or effectiveness.

**National Semiconductor Corporation
Americas**

Tel: 1-800-272-9959
Fax: 1-800-737-7018
Email: support@nsc.com

National Semiconductor Europe

Fax: +49 (0) 1 80-530 85 86
Email: europe.support@nsc.com
Deutsch Tel: +49 (0) 699508 6208
English Tel: +49 (0) 870 24 0 2171
Français Tel: +49 (0) 141 91 8790

**National Semiconductor
Asia Pacific Customer**

Response Group
Tel: 65-2544466
Fax: 65-2504466
Email: sea.support@nsc.com

**National Semiconductor
Japan Ltd.**

Tel: 81-3-5639-7560
Fax: 81-3-5639-7507

www.national.com

National does not assume any responsibility for any circuitry described, no circuit patent licenses are implied and National reserves the right at any time without notice to change said circuitry and specifications.