

National Semiconductor's

SPUSI2

USB Interface Dongle



User's Guide

August 2009

1.0 SPUSI2 USB Interface Dongle

What is the SPUSI2 USB Interface Dongle?

The SPUSI2 USB Interface Dongle is National Semiconductor's platform for interfacing to evaluation boards and reference boards with a Serial Peripheral Interface (SPI).

Examples included National Semiconductor's latest line of sensor boards (SP1202S01, SP1202S02, SP1202S03, SP1202S04, SP1602S01, and SP1602S02). These boards are a subset of the online WEBENCH Sensor Designer tool available at www.national.com.

Packing List

The SPUSI2 Board comes with the following components
SPUSI2 USB Interface Dongle
USB Cable

Picture of the SPUSI2

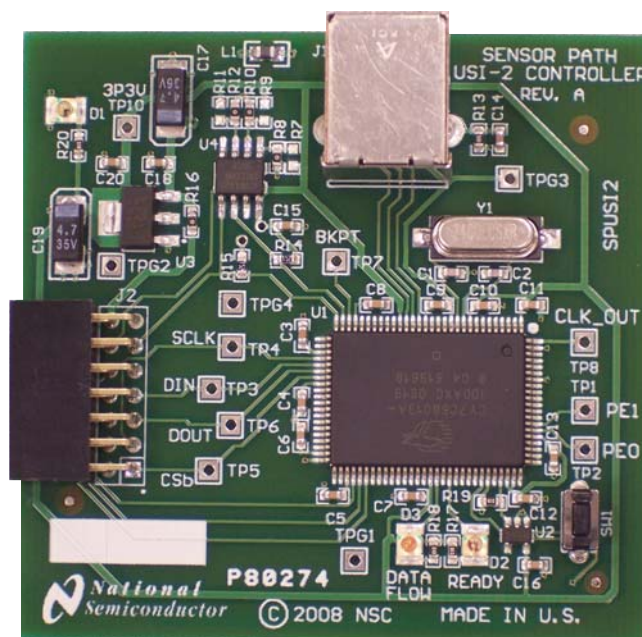

Component Description

The following table describes both the on-board connectors and the main components on the SPUSI2 board.

Component	Description
J1	USB cable connection
J2	General -use
U1	USB Microcontroller
D1	3.3V Power Indicator
D2	Ready Indicator
D3	Data Flow Indicator
SW1	Reset Switch for Microcontroller

Test Points

Test Point	Description
TP1	PE1
TP2	PE0
TP3	DIN
TP4	SCLK
TP5	CSB
TP6	DOUT
TP7	BKPT
TP10	3P3V (3.3V)
TPG1, TPG2, TPG3, TPG4	Ground

2.0 Power Requirements

The SPUSI2 board requires no external power supply. It is powered by the +5V available on the USB connector. The +5V is regulated down to +3.3V for the Microcontroller. The +5V and +3V are available on connector J2 on pins 14 and 13 respectively.

3.0 Setup Procedure

1. Download Sensor Path Control Panel Software onto your computer prior to connecting board to computer:
<http://www.national.com/analog/webench/sensors/spusi2>

2. Connect board to computer. The *Found New Hardware Wizard* will popup. Select *Yes, this time only* and click *Next*.

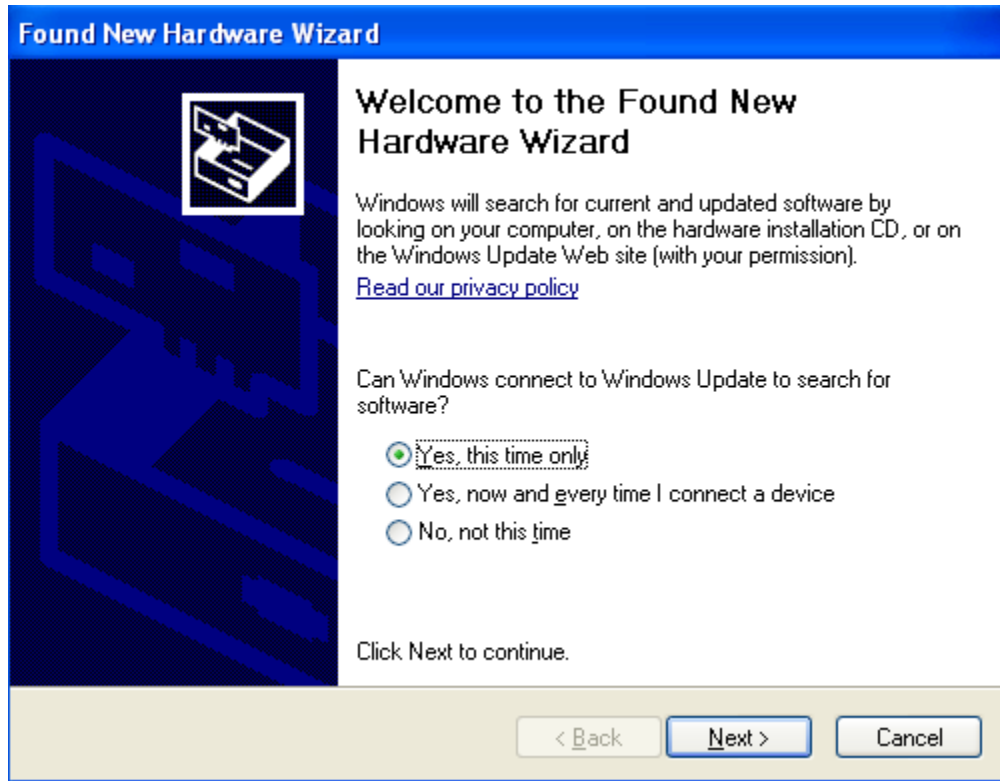

3. Select *Install the software automatically (Recommended)* and click *Next*.

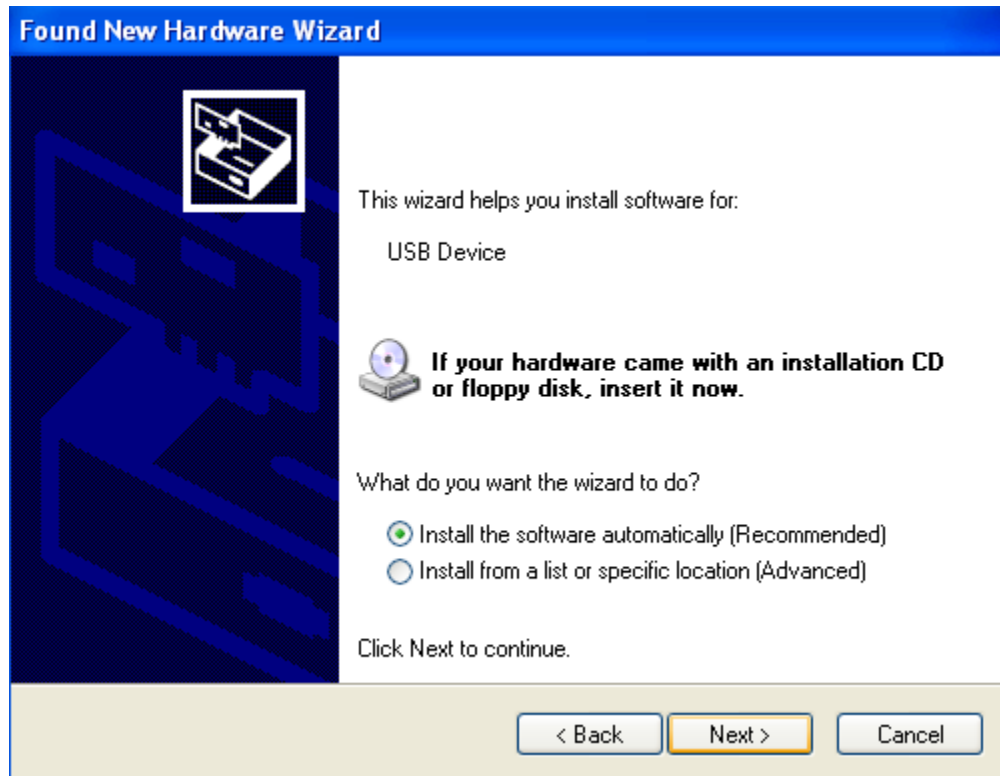

4. Wizard begins to install software for Sensor Signal Path 2008 Board. Click *Continue Anyway* on the *Hardware Installation* pop-up.



5. Click *Finish*.

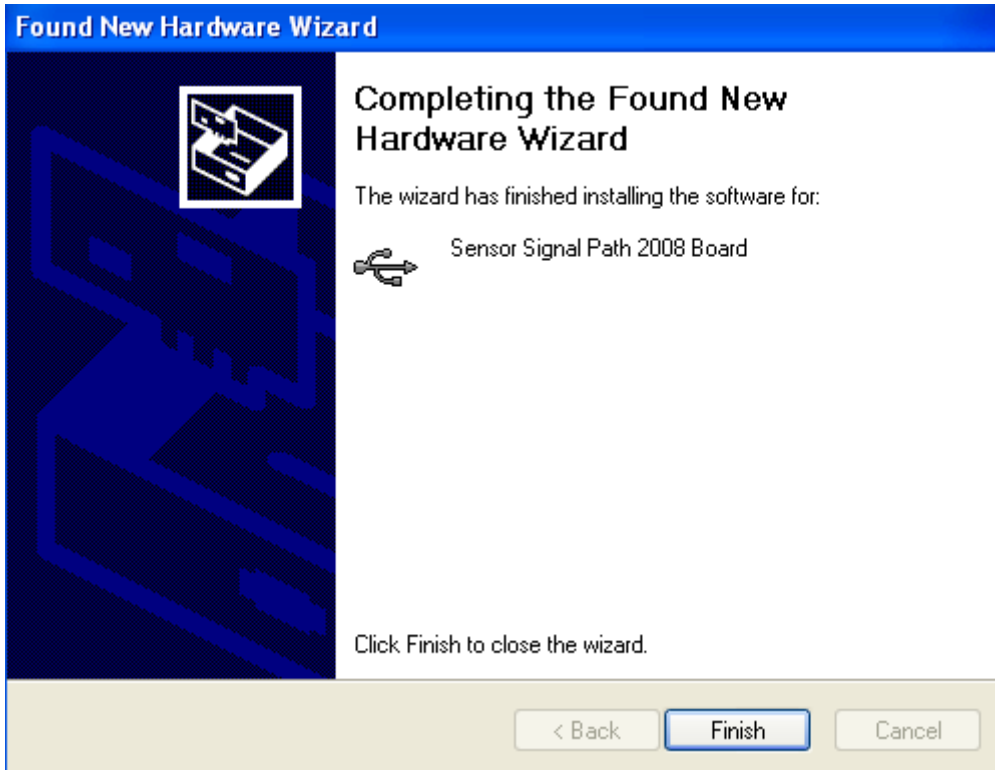

4.0 Schematic and Layout

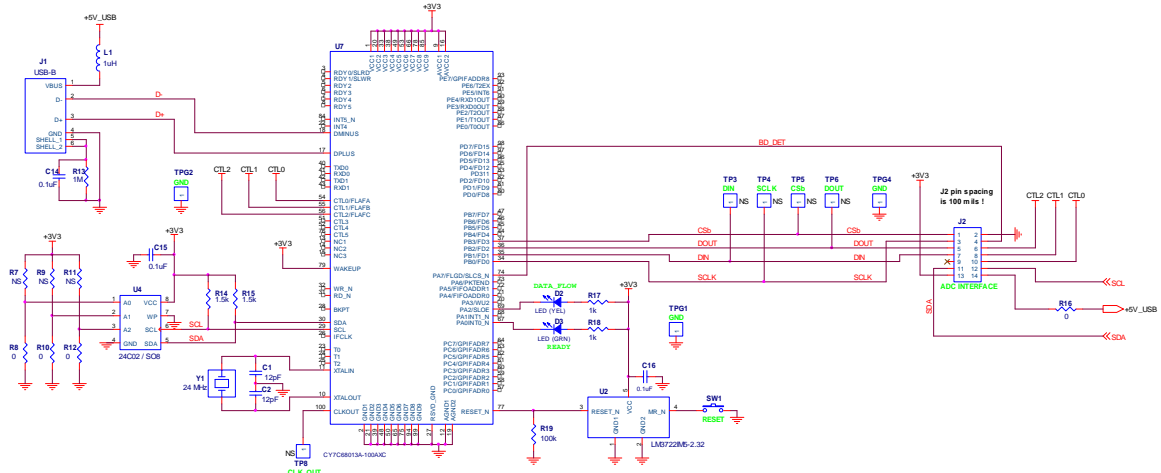

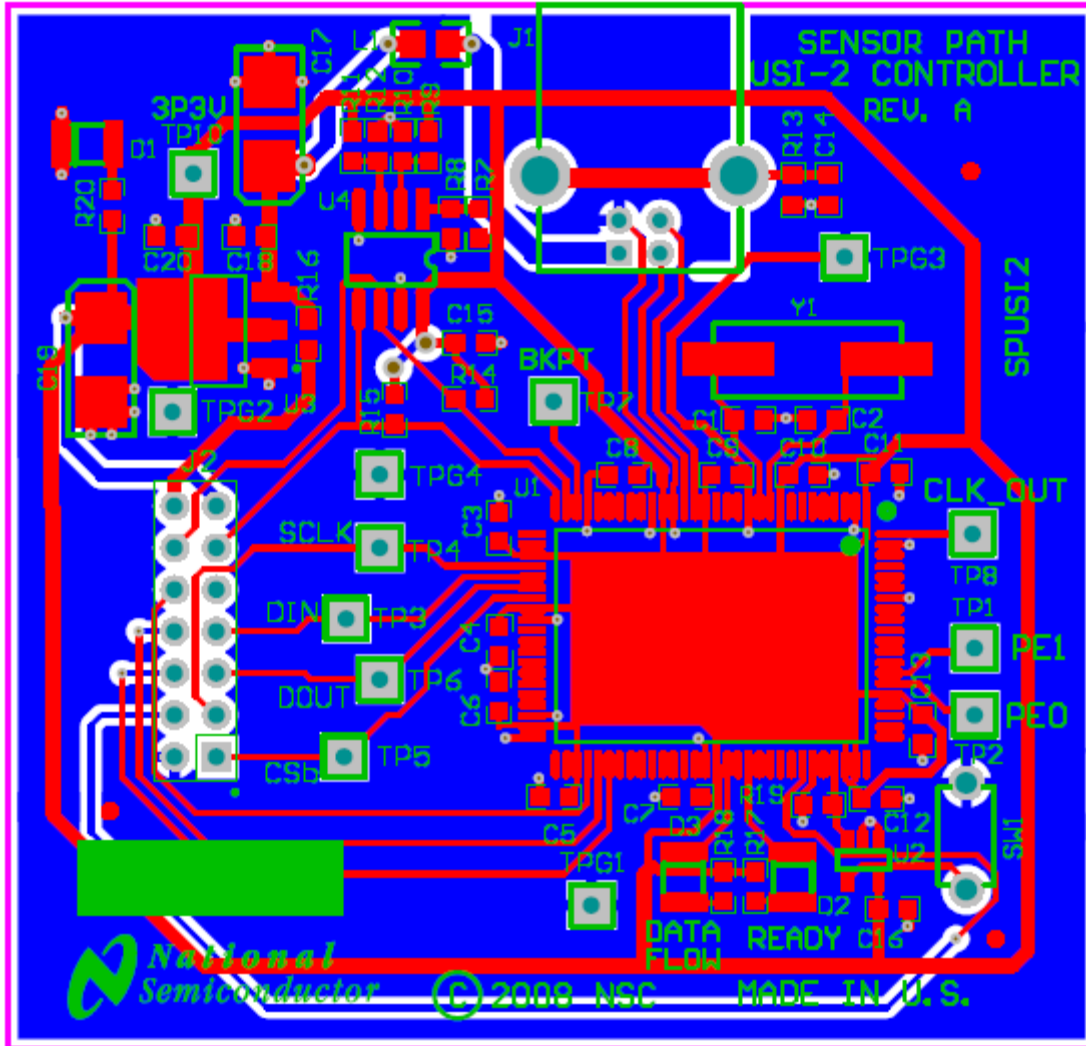

5.0 Bill of Materials

Item	Qty	Reference	Part	Source
1	2	C1, C2	12pF, 0805	Panasonic #ECJ-2VC1H120J Digi-Key #PCC120CNTR-ND
2	16	C3, C4, C5, C6, C7, C8, C9, C10, C11, C12, C13, C14, C15, C16, C18, C20	0.1µF, 16V, ±10%, 0805, X7R	Yageo #CC0805KRX7R7BB104 Digi-Key #311-1142-2-ND
3	2	C17, C19	4.7 uF, 16V, Tant, ±20%, size 1206	Vishay/Sprague #293D475X9016A2TE3 Digi-Key #718-1148-2-ND
4	1	D1	LED (RED)	Lite-On #LTST-C930KAKT Digi-Key #160-1461-1-ND
5	1	D2	LED (YEL)	Lite-On #LTST-C930YKT Digi-Key #160-1213-1-ND
6	1	D3	LED (GRN)	Lite-On #LTST-C930GKT Digi-Key #160-1212-1-ND
7	1	J1	USB Connector	Mil-Max 897-43-004-90-000000 Digi-Key #ED90064-ND
8	1	J2	2 x 7 Pin Female Header, R/A	Sullins #PPPC072LJBN-RC Digi-Key #S5560-ND
9	1	L1	1uH	Murata #BLM15AG102SN1 Digi-Key #490-1007-1-ND
10	-	R7, R9, R11	Not Stuffed	n/a
11	4	R8, R10, R12, R16	0Ω, 5%, 1/10W, 0603	Rohm #MCR03EZPJ000 Digi-Key #RHM0.0GTR-ND
12	1	R13	1MΩ, 5%, 1/10W, 0603	Rohm #MCR03EZPJ105 Digi-Key #RHM1.0MGTR-ND
13	2	R14, R15	1.5kΩ, 5%, 1/10W, 0603	Rohm #MCR03EZPJ152 Digi-Key #RHM1.5KGTR-ND
14	3	R17, R18, R20	1kΩ, 5%, 1/10W, 0603	Rohm #MCR03EZPJ102 Digi-Key #RHM1.0KGCT-ND
15	1	R19	100kΩ, 5%, 1/10W, 0603	Rohm #MCR03EZPJ104 Digi-Key #RHM100KGTR-ND
16	1	SW1	Switch, NO	C&K #PTS635SL50 Digi-Key #CKN9102-ND
17	-	TPG1, TPG2, TPG3, TPG4	Not Stuffed	n/a
18	-	TP3, TP4, TP5, TP6, TP8, TP10	Not Stuffed	n/a
19	1	U2	LM3722IM5-2.32	National Semi #LM3722IM5-2.32/NOPB Digi-Key #LM3722IM5-2.32CT-ND
20	1	U3	LM1117MPX-3.3 / SOT-223	National Semi #LM1117MPX-3.3/NOPB Digi-Key #LM1117MPX-3.3CT-ND
21	1	U4	AT24C02 / SO8	Atmel #AT24C02BN-SH-B Digi-Key #AT24C02BN-SH-B-ND
22	1	U7	CY7C68013A-100AXC	Cypress Semi #CY7C68013A-100AXC Digi-Key #428-1667-ND
23	1	Y1	24 MHz	ECS# ECS-240-12-5PX-TR Digi-Key #XC1001TR-ND
24	1		PCB	Advanced Circuits