

# LMH6518 Evaluation Board 551600272-001A

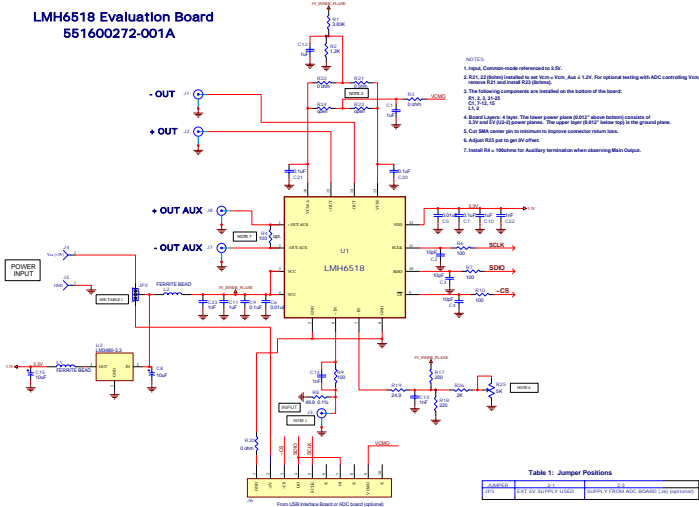

Table 1: Jumper Positions

JUMPER	2-1	2-2
JP1	EXT V <sub>S</sub> SUPPLY USED	SUPPLY FROM ADC BOARD (AN) (optional)

National Semiconductor Corporation				9/12/2008	
LMH6518 900 MHz VGA EVALUATION BOARD					
Assembly Part Number : 980600272-100					
Revision : A					
Bill of Materials					
Item	Part Number	Part Description	Qty	Ref Designator	Remark
1	551600272-001	LMH6518SQ 900MHz VGA EVALUATION BOARD PCB, RevA			NSC
2	LMH6518SQ	825 MHz, Digital Controlled, Variable Gain Amplifier	1	U1	NSC
3	LM3480IM3-3.3/NOPB	100 mA, SOT-23, Quasi Low-Dropout Linear Voltage Regulator	1	U2	NSC
4	GRM155R61A105KE15D	Capacitor, SMT, 1.0uF, 0402, X5R, 10%, 10V	4	C1, C10, C11, C12	Murata
5	GCM1555C1H100JZ13D	Capacitor, SMT, 10pF, 0402, NPO, 5%, 50V	3	C2, C3, C4	Murata
6	GRM155R71E103KA01D	Capacitor, SMT, 10nF, 0402, X7R, 10%, 25V	2	C5, C6	Murata
7	GRM155R71C104KA88D	Capacitor, SMT, 100nF, 0402, X7R, 10%, 16V	4	C7, C9, C20, C21	Murata
8	B45196H2106K109	Capacitor, Tantalum, 10uF, 3216, 10%, 10V	2	C8, C15	Kemet
9	GRM155R71H102KA01D	Capacitor, SMT, 1nF, 0402, X7R, 10%, 50V	4	C13, C14, C22, C23	Murata
10	LI1806E101R-10	FERRITE 500MA 100MHZ 100OHM 1806 SMD	2	L1, L2	Steward
11	CRCW04023K83FKED	Resistor, SMT, 3.83K, 1%, 0402, 1/16W	1	R1	Vishay/Dale
12	CRCW04021K20FKED	Resistor, SMT, 1.20K, 1%, 0402, 1/16W	1	R2	Vishay/Dale
13	CRCW04020000Z0ED	Resistor, SMT, 0 ohm, 5%, 0402, 1/16W	3	R3, R21, R22	Vishay/Dale
14	CRCW0402100RFKED	Resistor, SMT, 100, 1%, 0402, 1/16W	3	R6, R7, R10	Vishay/Dale
15	RG1005P-49R9-B-T5	Resistor, SMT, 49.9, 0.1%, 0402, 1/16W	1	R8	Susumu
16	RG1005P-101-B-T5	Resistor, SMT, 100, 0.1%, 0402, 1/16W	1	R9	Susumu
17	CRCW0402200RFKED	Resistor, SMT, 200, 1%, 0402, 1/16W	1	R17	Vishay/Dale
18	CRCW0402220RFKED	Resistor, SMT, 220, 1%, 0402, 1/16W	1	R18	Vishay/Dale
19	CRCW040224R9FKED	Resistor, SMT, 24.9, 1%, 0402, 1/16W	1	R19	Vishay/Dale
20	CRCW08050000Z0EA	Resistor, SMT, 0 ohm, 5%, 0805, 1/8W	1	R20	Vishay/Dale
21	NO LOAD	NO LOAD	2	R23, R24	NO LOAD
22	ST4ETA502	POT, 5K, 4MM SMT	1	R25	Copal
23	CRCW04022K00FKED	Resistor, SMT, 2.00Kohm, 1%, 0402, 1/16W	1	R26	Vishay/Dale
24	142-0711-821	SMA CONNECTOR, EDGE MOUNT	5	J1, J2, J3, J7, J8	EMERSON
25	5000	Test Point, RED	1	J4	Keystone
26	5001	Test Point, Black	1	J5	Keystone
27	PBC05DAAN	HEADER 2X5	1	J6	Sullins
28	22-28-4033	HEADER 3PIN	1	JP3	Waldom/Molex
29	382811-6	Jumper Shunt, 15uin gold plated, 0.100" pitch	1	JP3_SH	Tyco/AMP

