



This Page Intentionally Left Blank

## Table of Contents

1. Introduction.....	4
2. Equipment Setup.....	4
2.1 Equipment List.....	4
2.2 Equipment Connection Diagram .....	4
3. LM96080 Board Setup.....	5
3.1 Component Placement Diagram.....	5
3.2 Jumper Options.....	6
3.3 Powering the Board.....	8
4. SensorEval Software.....	8
4.1 Installing the Software.....	9
4.2 Setting the Address.....	9
4.3 LM906080 Registers.....	10
5. Quick Start.....	12
5.1 Setting Up the Board.....	12
5.1 Starting the Software.....	12
6. Appendix.....	13
6.1 Board Schematic.....	15
6.2 Board Layouts.....	18
6.3 Bill of Materials.....	17

## 1. INTRODUCTION

The LM96080/RoHS Evaluation Board Kit (consisting of the LM96080 Evaluation Board, the SensorEval Software, and this user's guide) is designed to ease evaluation and design-in of National Semiconductor's LM96080 10-bit System Hardware Monitor with 2-Wire Serial Interface.

Writing and reading to the LM96080's Registers are simplified by connecting the LM96080 Evaluation Board to a Personal Computer (PC) via a USB cable and running the SensorEval software. The Cypress Microcontroller on the board will generate a 2-wire I<sup>2</sup>C serial interface, and the SensorEval software will be used to control the LM96080.

This document will describe the connection between the LM96080 Evaluation Board and the SensorEval Software, explain how to use the software, and provide a quick start as well as the schematic, layouts, and BOM of the board.

## 2. EQUIPMENT SETUP

**2.1. Equipment List** - The LM96080 setup requires the following equipments:

1. LM96080 Evaluation Board
2. Personal Computer with SensorEval Software
3. USB Connector
4. Power Supply (optional)
5. Oscilloscope (optional)
6. Multimeter (optional)

**2.2. Equipment Connection Diagram** – figure 1 shows the connection diagram between the board and the PC.

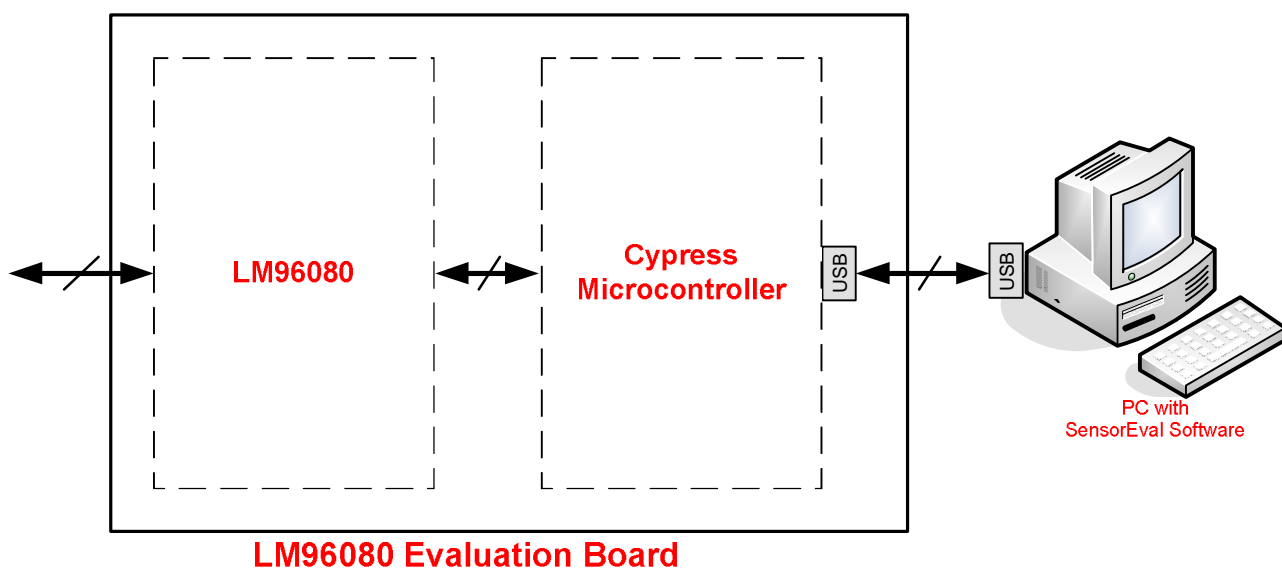

Figure 1 – Equipment Connection Diagram

### 3. LM96080 BOARD SETUP

#### 3.1. Component Placement Diagram

Figure 2 shows a Components Placement Diagram for the LM96080 Evaluation Board. Because the board was built to evaluate either the LM96080 and/or the ADC128D818, some of the components on the board are not needed and are thus not included in the block diagram.

The components that are shown on the diagram are critical parts that customers will use the most. The diagram however, excludes resistors, capacitors, inductors, and test pins. Furthermore, the components are not drawn to size. The purpose of the diagram is to show the location of critical components on the LM96080 Evaluation Board.

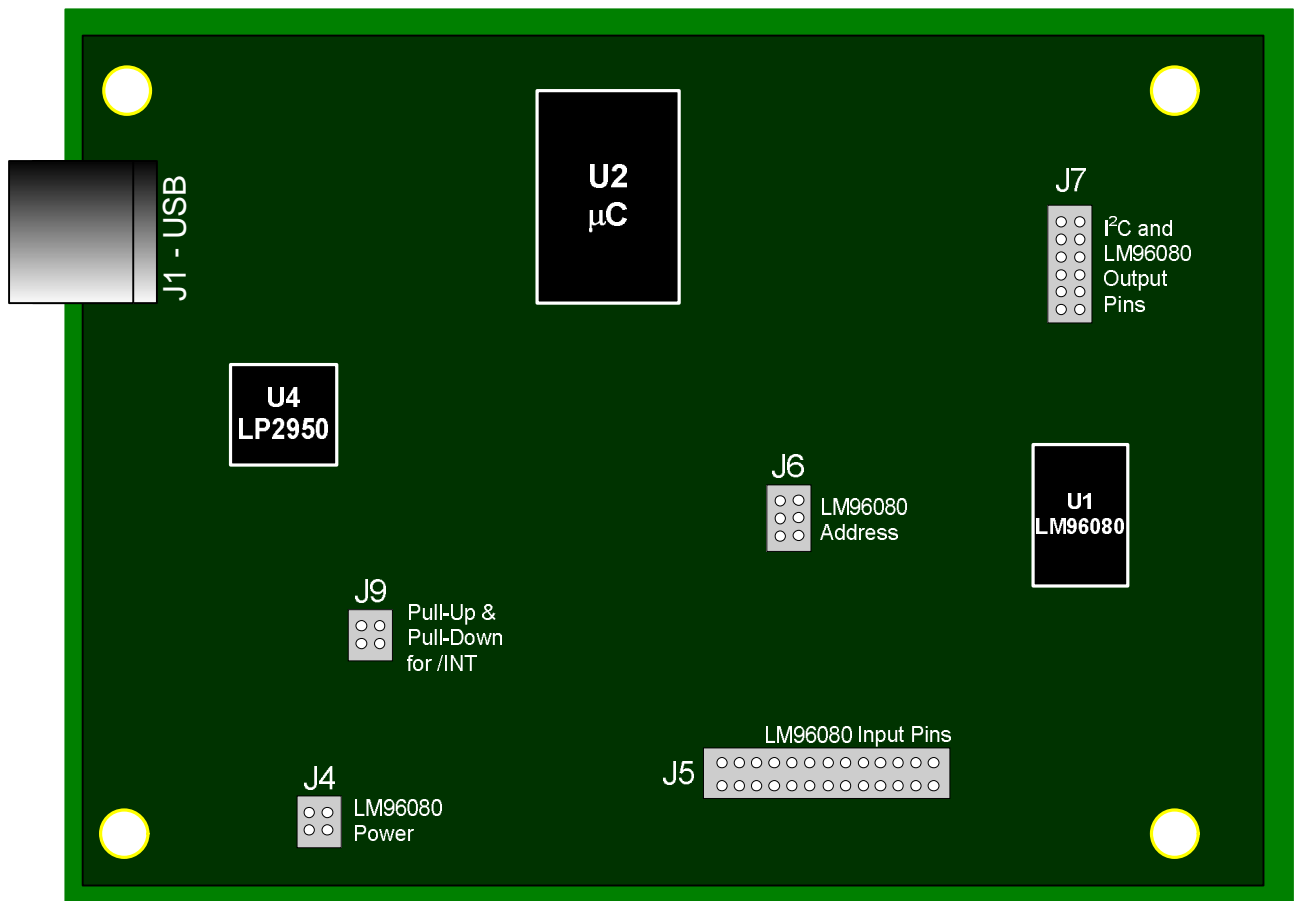

Figure 2 – Components Placement Diagram

### 3.2. Jumper Options

Follow the jumper options below to connect the board before powering it. To use SensorEval Software to control the LM96080, connect the 'Recommended' jumpers. Since this evaluation board can be used to test the LM96080 or the ADC128D818 (not stuffed), or some of these headers are used for measurement purposes only, please do not connect the 'Not Available' or the 'Prohibited' jumpers.

Part#	Description	Pins	Jumper	Un-jumper
J1	USB	N/A	Connect SensorEval Software to LM96080 Board. 'Recommended'	NOT connecting the SensorEval Software to LM96080 Board.
J2	SMBus Connection	N/A	'Not Available'	This header is used to probe the Serial Clock and Serial Data Line for the I <sup>2</sup> C interface from the Cypress microcontroller.
J4	DUT (LM9608) Power	Pin 1 & Pin 3	Connect +3.3V from USB to LM96080's V <sup>+</sup> pin. 'Recommended'	LM96080's V <sup>+</sup> pin has to be sourced externally. In this case, connect a +3.3V power supply to J4.P3 and J4.P4 (GND)
		Pin 2 & Pin 4	(Not Necessary)	Use as ground pins for the external power supply.
J5	DUT Signal Side	Pin 1 & Pin 2	Connect IN0 to 2.5V.	Source IN0 externally via a power supply.
		Pin 3 & Pin 4	Connect IN1 to 2.5V.	Source IN1 externally via a power supply.
		Pin 4 & Pin 5	Connect IN2 to 2.5V.	Source IN2 externally via a power supply.
		Pin 6 & Pin 7	Connect IN3 to 2.5V.	Source IN3 externally via a power supply.
		Pin 8 & Pin 9	Connect IN4 to 2.5V.	Source IN4 externally via a power supply.
		Pin 10 & Pin 11	Connect IN5 to 2.5V.	Source IN5 externally via a power supply.
		Pin 12 & Pin 13	Connect IN6 to 2.5V.	Source IN6 externally via a power supply.
		Pin 14 & Pin 15	Connect $\overline{\text{INT\_IN}}$ to Ground.	Connect $\overline{\text{INT\_IN}}$ to 3.3V via pull-up resistor R36.
		Pin 16 & Pin 17	Connect $\overline{\text{BTI}}$ to Ground.	Leave $\overline{\text{BTI}}$ floating. Note: Unlike shown in the schematic, R35 is un-populated on the board.
		Pin 18 & Pin 19	Connect GPI (CI) to Ground.	Connect GPI (CI) to 3.3V via pull-up resistor R34.
		Pin 20 & Pin 21	Connect NTEST_IN/RESET_IN to Ground. Doing this will place the LM96080 in NAND tree test mode, and thus the part will not respond to normal I <sup>2</sup> C communication.	Connect NTEST_IN/RESET_IN to 3.3V via pull-up resistor R33. 'Recommended'
		Pin 22 & Pin 23	Connect FAN1 to the Microcontroller.	Connect FAN1 to ground via resistor R41. Pin 23 can also be used to apply a fan tachometer signal.
Pin 24 & Pin 25	Connect FAN2 to the Microcontroller.	Connect FAN2 to ground via resistor R40. Pin 25 can also be used to apply a fan tachometer signal.		

Part#	Description	Pins	Jumper	Un-jumper
J6	Address	Pin 1 & Pin 2	Connect the LM96080's LSB address A0 to ground.	Connect the LM96080's LSB address A0 to +3.3V via pull-up resistor R26.
		Pin 3 & Pin 4	Connect the LM96080's middle bit address A1 to ground.	Connect the LM96080's middle bit address A1 to +3.3V via pull-resistor R23.
		Pin 5 & Pin 6	Connect the LM96080's MSB address A2 to ground.	Connect the LM96080's MSB address A2 to +3.3V via pull-resistor R24.
J7	LM96080 Output and Serial Interface	Pin 1 & Pin 2	Connect GND to GND.	Leave the GNDs un-connected <b>(Recommended)</b> .
		Pin 3 & Pin 4	Connect the LM96080's SDA pin to the Cypress Microcontroller ( $\mu$ C)'s SDA pin. <b>'Recommended'</b>	NOT using the Cypress $\mu$ C to interface to the LM96080.
		Pin 5 & Pin 6	Connect the LM96080's SCL pin to the Cypress Microcontroller ( $\mu$ C)'s SCL pin. <b>'Recommended'</b>	NOT using the Cypress $\mu$ C to interface to the LM96080.
		Pin 7 & Pin 8	Connect the LM96080's $\overline{\text{INT}}$ pin to the Cypress Microcontroller ( $\mu$ C)'s Interrupt pin. <b>'Recommended'</b>	NOT connecting the $\overline{\text{INT}}$ pin to the microcontroller.
		Pin 9 & Pin 10	Connect the LM96080's $\overline{\text{GPO}}$ pin to the Cypress Microcontroller ( $\mu$ C)'s "RDY0/SLRD" general purpose pin. <b>'Recommended'</b>	NOT connecting the $\overline{\text{GPO}}$ pin to the microcontroller.
		Pin 11 & Pin 12	Connect the LM96080's $\overline{\text{RST\_OUT/OS}}$ pin to the Cypress Microcontroller ( $\mu$ C)'s "RDY1/SLWR" general purpose pin. <b>'Recommended'</b>	NOT connecting the $\overline{\text{RST\_OUT/OS}}$ pin to the microcontroller.
J8	<b>'Prohibited'</b>	Pin 1 & Pin 2	<b>'Prohibited'</b>	<b>'Recommended'</b>
		Pin 3 & Pin 4		
		Pin 5 & Pin 6		
J9	Pull-Up and Pull-Down	Pin 1 & Pin 2	Force $\overline{\text{INT}}$ to 3.3V via pull-up resistor R30.	Leave $\overline{\text{INT}}$ floating.
		Pin 2 & Pin 3	Force $\overline{\text{INT}}$ to ground via pull-down resistor R42.	Leave $\overline{\text{INT}}$ floating.
J10	<b>'Prohibited'</b>	Pin 1 & Pin 2	<b>'Prohibited'</b>	<b>'Recommended'</b>
J11	Measurements (Not Stuffed)	ALL	<b>'Not Available'</b>	<b>'Not Available'</b>

**Table I – Jumpers and Connectors Functions**

### **3.3. Powering the Board**

There are two options to power the board. The first option is to use the +3.3V from the USB to source  $V^+$ . To use this option, connect pin 1 of J4 (J4.P1) to J4.P3. For an easy and quick start, National recommends using this option.

The second option is to leave J4.P1 and J4.P3 unconnected, and connect a power supply of +3.3V to +5.5V (as stated in the datasheet) to J4.P3 and J4.P4 (GND). If the user is using the Cypress microcontroller and the SensorEval software to evaluate the LM96080, this option is NOT recommended.

## 4. SENSOREVAL SOFTWARE

### 4.1. Installing the Software

1. Unzip the file "SensorEval\_1.1.0v.zip"
2. Click on the SensorEval's executable file "SensorEval\_1.1.0v\_Setup.exe" to install the SensorEval software.
3. When complete, click on the "Launch SensorEval.exe" icon to start the software.
4. If an 'Open Device' window pops up and asks to select a device file, click on the 'LM96080'.
5. When a window asking for the platform (figure 3) pops up, check the "LM96080 Evaluation Board" and click "Ok"



Figure 3 – SensorEval Pop-Up Window

6. You are now ready to start using the SensorEval software!

### 4.2. Setting the Address

The user is allowed to choose any addresses he or she desires. However, whatever addresses the user chooses, the same address must match the SensorEval's I<sup>2</sup>C address.

The following steps show how to program the address:

1. Select what address to program the EEPROM. The address bits are A2A1A0, where A2 is the MSB. Table II below shows how to jumper J6 in order to select the desire address. National recommends leaving all J6 pins un-jumpered so that the address A2A1A0 = 111.

Address	Jumper	Un-Jumper
A0 =	LOW	HIGH
A1 =	LOW	HIGH
A2 =	LOW	HIGH

Table II – Address Header on the Evaluation Board

- In the SensorEval Software, select the I<sup>2</sup>C address that matches the address bit selected in step 1. Use table III to set the correct I<sup>2</sup>C address, which is located on the top left hand corner of the SensorEval Software (figure 4).

Address (A2A1A0)	I2C Address
000	28
001	29
010	2a
011	2b
100	2c
101	2d
110	2e
111	2f

Table III - Address and I2C Address Comparison

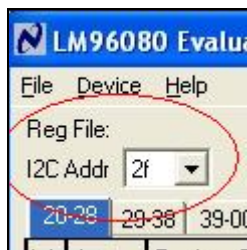

Figure 4 – I<sup>2</sup>C Address

### **4.3. LM96080 Registers**

The SensorEval software allows writing to and reading from registers. The functionality of these registers can be found in section 12 of the LM96080 datasheet.

To navigate through the register map, use the tab above the registers in the SensorEval software. As shown in figure 5, the first tab contains nine registers, and there are seven total tabs for all of the 63 LM96080 registers.

The screenshot shows the 'LM96080 Evaluation Board' software window. At the top, there is a menu bar with 'File', 'Device', and 'Help'. Below the menu bar is a control panel with fields for 'Reg File:', 'I2C Addr' (set to '2f'), and buttons for 'Start Plot', 'Start Log', 'Read Regs', 'Read Cont' (set to 'OFF'), and 'Write Regs'. There are also checkboxes for 'Write On Change' and 'Read After Write'. Below the control panel is a tabbed interface with tabs for '20-28', '29-38', '39-00', '01-02', '03-04', '05-07', and '08'. The '20-28' tab is selected, displaying a table of register bit fields.

Adr	Attr	Register Bit Field	Register Bits (click)	Hex	Bit Field Value
20		IN0	0 0 0 0 0 0 1 0	02	0.025 v
20		IN0	1 0 0 0 0 0 0 0	80	
21		IN1	0 0 0 0 0 0 1 0	02	0.023 v
21		IN1	0 1 0 0 0 0 0 0	40	
22		IN2	0 0 0 0 0 0 1 0	02	0.020 v
22		IN2	0 0 0 0 0 0 0 0	00	
23		IN3	0 0 0 0 0 0 0 1	01	0.018 v
23		IN3	1 1 0 0 0 0 0 0	C0	
24		IN4	0 0 0 0 0 0 0 1	01	0.018 v
24		IN4	1 1 0 0 0 0 0 0	C0	
25		IN5	0 0 0 0 0 0 0 1	01	0.018 v
25		IN5	1 1 0 0 0 0 0 0	C0	
26		IN6	0 0 0 0 0 0 0 1	01	0.018 v
26		IN6	1 1 0 0 0 0 0 0	C0	
27		Temperature	0 0 0 1 0 1 1 0	16	22 DegC
28		FAN1	1 1 1 1 1 1 1 1	FF	0 RPM

Figure 5 – Example LM96080 Register in SensorEval Software

## 5. QUICK START

This section briefly explains how the user can quickly start the SensorEval software to evaluate the LM96080.

### 5.1. Setting Up the Board

1. Jumper J4.P1 and J4.P3 to source the LM96080 with +3.3V from the USB.
2. To ensure that these I<sup>2</sup>C interface and output pins are connected to the microcontroller, jumper the following pins on J7:
  - a. J7.P3 to J7.P4 – connect SDA to the microcontroller, U7.
  - b. J7.P5 to J7.P6 – connect SCL to the microcontroller, U7.
  - c. J7.P7 to J7.P8 – connect  $\overline{\text{INT}}$  to the microcontroller, U7.
  - d. J7.P9 to J7.P10 – connect  $\overline{\text{GPO}}$  to the microcontroller, U7.
  - e. J7.P11 to J7.P12 – connect RST\_OUT/OS to the microcontroller, U7.

### 5.2. Starting Software

1. Open SensorEval Software
2. Set the “I2C Addr” field, as explained in section 4.2
3. To start the program, set address 0x00, bit 0, ‘START’ to 1 (Start Monitoring).
4. To start monitoring the interrupts, set address 0x00, bit 3, ‘INT#\_Clear’ to 0 (Start Monitoring INT). Note that setting this bit to a 1 will not only stop monitoring the interrupt, but the conversion will be stopped as well.
5. To choose a continuous register update, set the “**Read Cont**” field at the top of the software to ‘All Regs’ or ‘Value Regs’ (figure 6). To manually read the registers, set this field to ‘OFF’ and push the “Read Regs” button for every read.

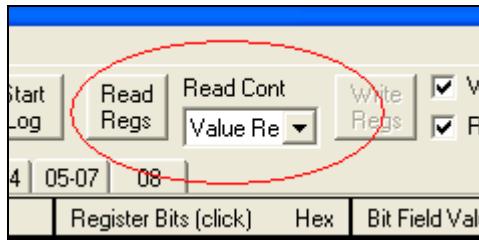

Figure 6 – “Read Cont” field

6. To start programming the registers, refer to section 12 of the LM96080 datasheet for more information.

## 6. Appendix

### 6.1. Board Schematic

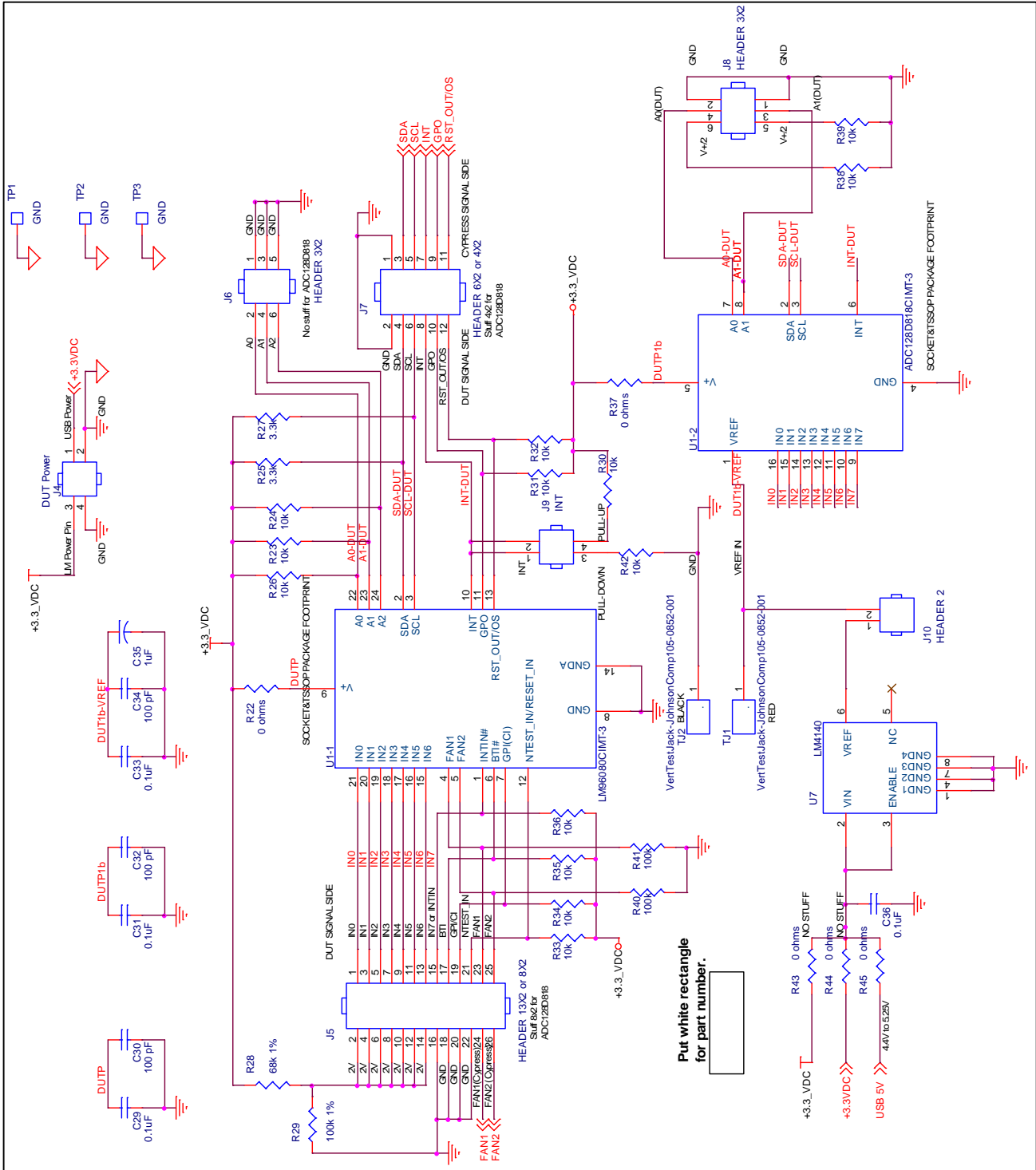
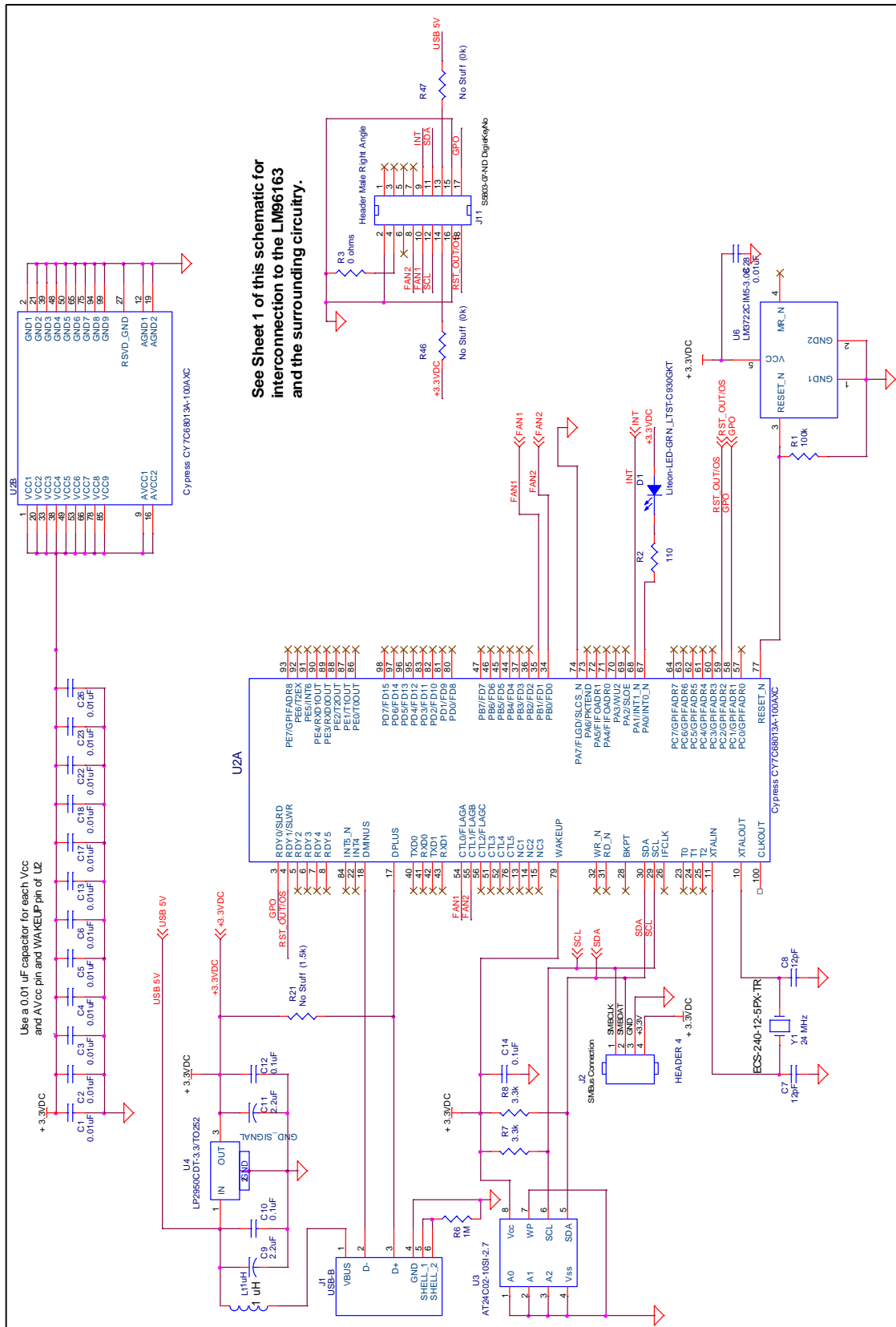

Figure 7 – LM9680 Evaluation Board Schematic, Page 1



See Sheet 1 of this schematic for interconnection to the LM96163 and the surrounding circuitry.

Figure 8 – LM96080 Evaluation Board Schematic, Page 2

## 6.2. Board Layouts

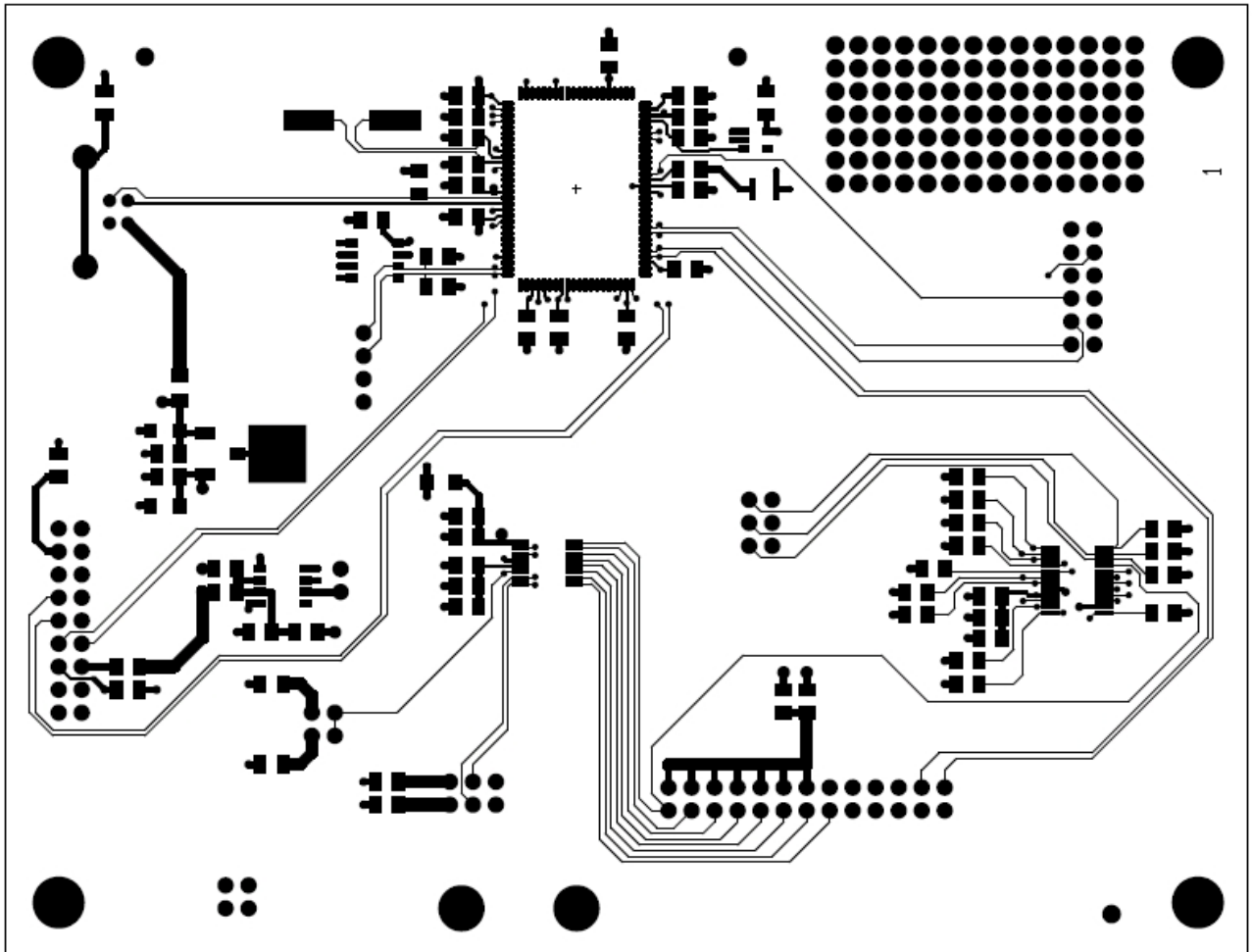

Figure 9 – Top Layer of the LM96080 Evaluation Board

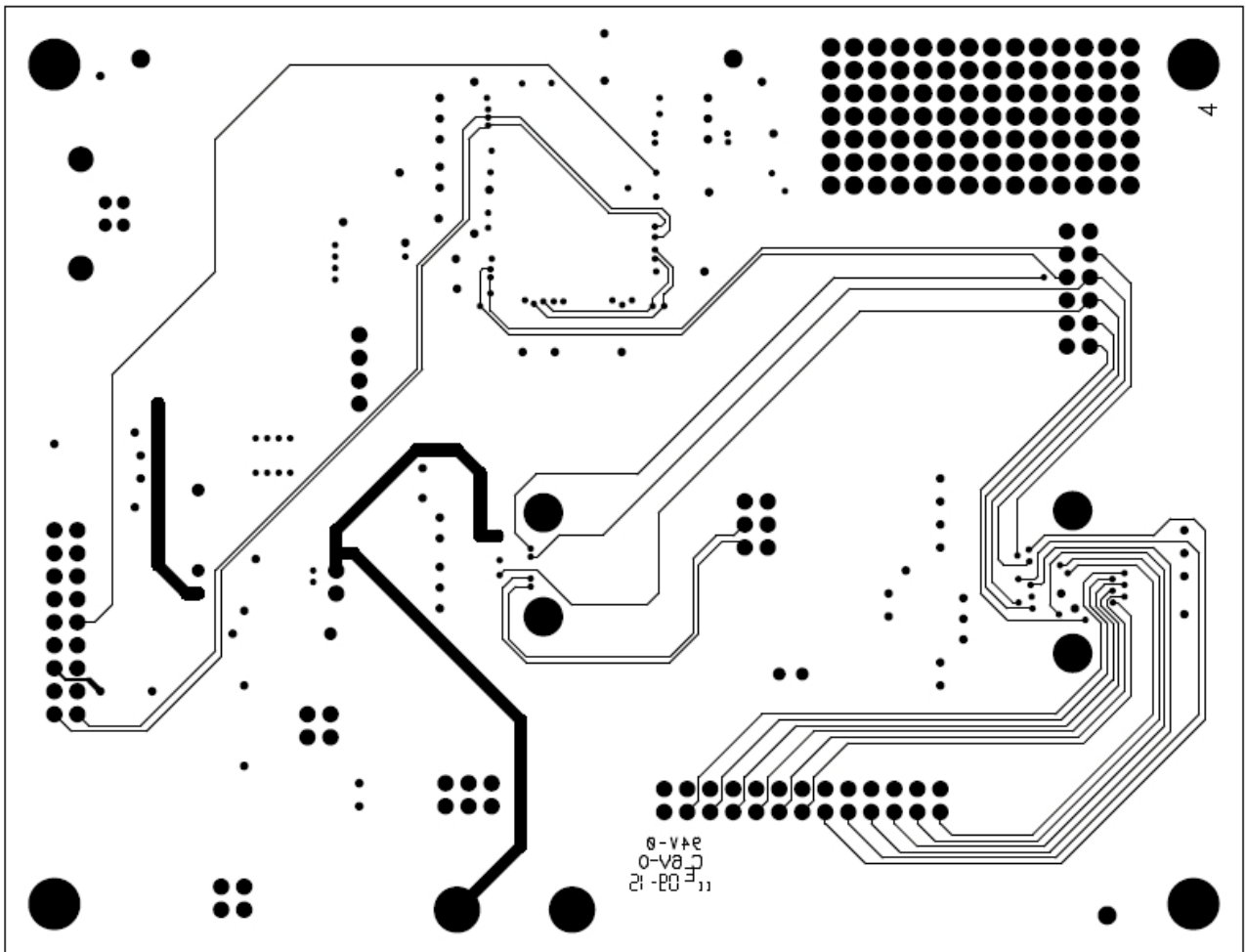

Figure 10 – Bottom Layer of the LM96080 Evaluation Board

### 6.3. Bill of Materials

Item	Qty	Reference	Part	Manf.	Manf. Order #
1	13	C1,C2,C3,C4,C5,C6,C13,C17,C18,C22,C23,C26,C28	0.01uF	Panasonic	ECP-U1C103MA5
2	2	C7,C8	12pF	Panasonic	ECJ-2VC1H330J
3	2	C9,C11	2.2uF	Panasonic	ECS-T1AY225R
4	7	C10,C12,C14,C29,C31,C3,C36	0.1uF	Panasonic	ECP-U1C104MA5
5	3	C30,C32,C34	100 pF	Panasonic	ECJ-2VC1H101J
6	1	C35	1uF	Panasonic	ECS-T1AY225R
7	1	D1	Liteon-LED-GRN_LTST-C930GKT	Lite-On	LTST-C930GKT
8	1	J1	USB-B	Molex	67068-0000
9	1	J2	HEADER 4		
10	1	J4	DUT Power		
11	1	J5	HEADER 13X2 or 8X2		
12	2	J6,J8	HEADER 3X2		
13	1	J7	HEADER 6X2 or 4X2		
14	1	J9	INT		
15	1	J10	HEADER 2		
16	1	J11	Header Male Right Angle	Molex	71764-0030
17	1	L1	1uH	Panasonic	
18	3	R1,R40,R41	100k		
19	1	R2	110		
20	6	R3,R22,R37,R43,R44,R45	0 ohms		
21	1	R6	1M		
22	4	R7,R8,R25,R27	3.3k		
23	1	R21	No Stuff (1.5k)		
24	13	R23,R24,R26,R30,R31,R32,R33,R34,R35,R36,R38,R39,R42	10k		
25	1	R28	68k 1%		
26	1	R29	100k 1%		
27	2	R46,R47	No Stuff (0k)		
28	1	TJ1	VertTestJack-JohnsonComp105-0852-001	Johnson Components	105-0852-001
29	1	TJ2	VertTestJack-JohnsonComp105-0852-001	Johnson Components	105-0853-001
30	3	TP1,TP2,TP3	GND		
31	1	U2	Cypress CY7C68013A-100AXC	Cypress	CY7C68013A-100AXC
32	1	U3	AT24C02-10SI-2.7	Atmel	AT24C02-10SI-2.7
33	1	U4	LP2950CDT-3.3/TO252	National	LP2950CDT-3.3
34	1	U6	LM3722CIM5-3.08	NSC	LM3722EM5-3.08
35	1	U7	LM4140	National	LM4140ACM-2.5
36	1	U1-1	LM96080CIMT-3	National	240228/LM96080

Item	Qty	Reference	Part	Manf.	Manf. Order #
37	1	U1-2	ADC128D818CIMT-3	National	TSSOP16S/ADC128D818
38	1	Y1	24 MHz	ECS	ECS-240-12-5PX-TR

Table IV – Bill of Material



**BY USING THIS PRODUCT, YOU ARE AGREEING TO BE BOUND BY THE TERMS AND CONDITIONS OF NATIONAL SEMICONDUCTOR'S END USER LICENSE AGREEMENT. DO NOT USE THIS PRODUCT UNTIL YOU HAVE READ AND AGREED TO THE TERMS AND CONDITIONS OF THAT AGREEMENT. IF YOU DO NOT AGREE WITH THEM, CONTACT THE VENDOR WITHIN TEN (10) DAYS OF RECEIPT FOR INSTRUCTIONS ON RETURN OF THE UNUSED PRODUCT FOR A REFUND OF THE PURCHASE PRICE PAID, IF ANY.**

The LM96080 Evaluation Board is intended for product evaluation purposes only and is not intended for resale to end consumers, is not authorized for such use and is not designed for compliance with European EMC Directive 89/336/EEC, or for compliance with any other electromagnetic compatibility requirements.

National Semiconductor Corporation does not assume any responsibility for use of any circuitry or software supplied or described. No circuit patent licenses are implied.

**LIFE SUPPORT POLICY**

NATIONAL'S PRODUCTS ARE NOT AUTHORIZED FOR USE AS CRITICAL COMPONENTS IN LIFE SUPPORT DEVICES OR SYSTEMS WITHOUT THE EXPRESS WRITTEN APPROVAL OF THE PRESIDENT OF NATIONAL SEMICONDUCTOR CORPORATION. As used herein:

1. Life support devices or systems are devices or systems which, (a) are intended for surgical implant into the body, or (b) support or sustain life, and whose failure to perform, when properly used in accordance with instructions for use provided in the labeling, can be reasonably expected to result in a significant injury to the user.
2. A critical component is any component in a life support device or system whose failure to perform can be reasonably expected to cause the failure of the life support device or system, or to affect its safety or effectiveness.

<b>National Semiconductor Corporation Americas</b> Tel: 1-800-272-9959 Fax: 1-800-737-7018 Email: support@nsc.com	<b>National Semiconductor Europe</b> Fax: +49 (0) 1 80-530 85 86 Email: europe.support@nsc.com Deutsch Tel: +49 (0) 699508 6208 English Tel: +49 (0) 870 24 0 2171 French Tel: +49 (0) 141 91 8790	<b>National Semiconductor Asia Pacific Customer Response Group</b> Tel: 65-2544466 Fax: 65-2504466 Email: sea.support@nsc.com	<b>National Semiconductor Japan Ltd.</b> Tel: 81-3-5639-7560 Fax: 81-3-5639-7507
<a href="http://www.national.com">www.national.com</a>			

National does not assume any responsibility for any circuitry described, no circuit patent licenses are implied and National reserves the right at any time without notice to change said circuitry and specification.