

**LM26LV Evaluation Board User's Guide**

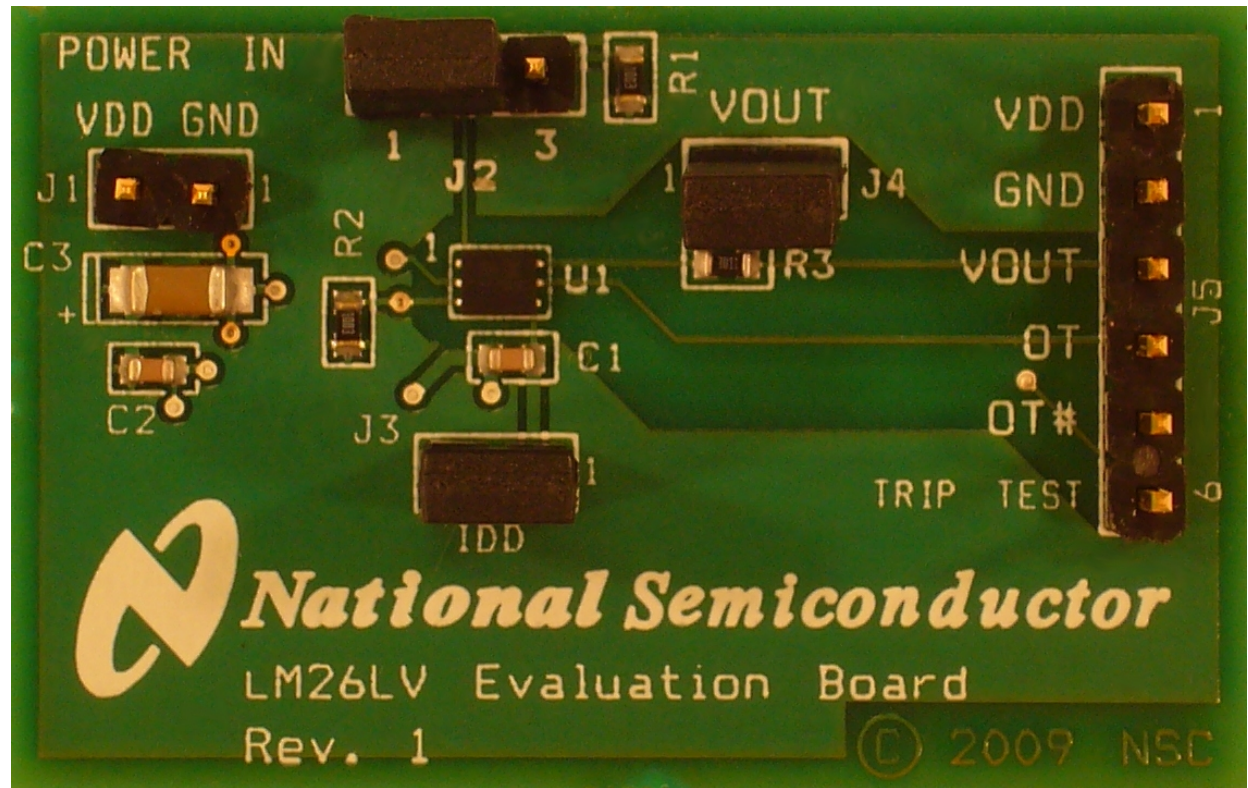

# LM26LV Evaluation Board User's Guide

## Table of Contents

Table of Contents	2
References	3
1.0 Introduction	4
1.1 Block Diagram	4
2.0 Quick Start	5
2.1 Quick Start Diagram	5
3.0 Functional Description	6
3.1 LM26LV Evaluation Board Connection Table	6
4.0 Electrical and Mechanical Specifications	7
4.1 Electrical Specifications	7
4.2 Electrical Schematic	7
4.3 Evaluation Board Layout	8
4.4 Bill of Materials	9
4.5 Mechanical Specifications	9

## LM26LV Evaluation Board User's Guide

### References

1. "LM26LV 1.6V, LLP-6, Factory Preset Temperature Switch and Temperature Sensor" datasheet.

The latest copy of the **LM26LV** datasheet can be obtained by going to the National Semiconductor website [www.national.com](http://www.national.com), by searching on "**LM26LV**", and then downloading the **LM26LV**.pdf file.

## 1.0 Introduction

The LM26LV Evaluation Board offers a convenient way to study the operation and performance of the LM26LV Temperature Switch and Temperature Sensor.

This evaluation board features LM26LV-105 (U1) which produces analog voltage signal inversely proportional to temperature, and is factory programmed to raise the OVERTEMP alarm once ambient temperature reaches 105°C.

Simplicity of the board speaks to the simplicity of use of LM26LV i.e. this temperature sensor does not require any external components for proper operation.

The evaluation board's main function is to provide a robust means of attachment of the power supply and test equipment – in most cases a digital multi-meter is the only instrument needed for testing. All components, besides U1, are present for tester's convenience, and are not necessary in most applications: J2 provides means of enabling TRIP TEST function, J3 provides for easy measurement of  $I_{DD}$ , J4 and R3 give an option of inserting resistance in series with VTEMP output which may be necessary when driving heavy capacitive load, and R2 is the pull-up for the open drain output.

Block diagram in section 1.1 gives the general overview of the evaluation board in its default state.

## 1.1 Block Diagram

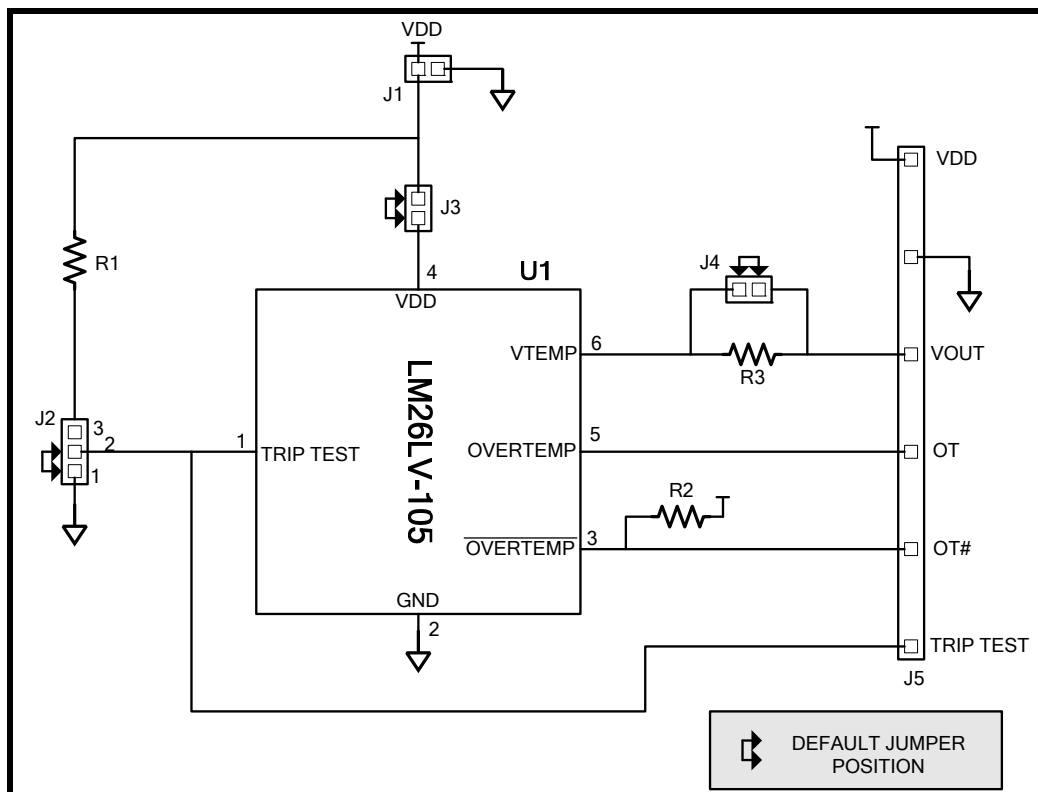

**FIGURE 1.1 Evaluation Board Block Diagram**

## 2.0 Quick Start

Prior to applying power to the LM26LV Evaluation Board, the default jumper positions in J2, J3 and J4 headers should be verified.

The power supply should be adjusted to source 1.6 to 5.5V DC. Source current compliance may be set as low as 100uA.

Once the power is applied, via J1 header, the voltmeter reading at VOUT pin of header J5 should be in the vicinity of 1.35V. The exact value of output voltage VOUT depends on the ambient temperature.

The diagram in section 2.1 shows the LM26LV evaluation board during a typical bench test.

## 2.1 Quick Start Diagram

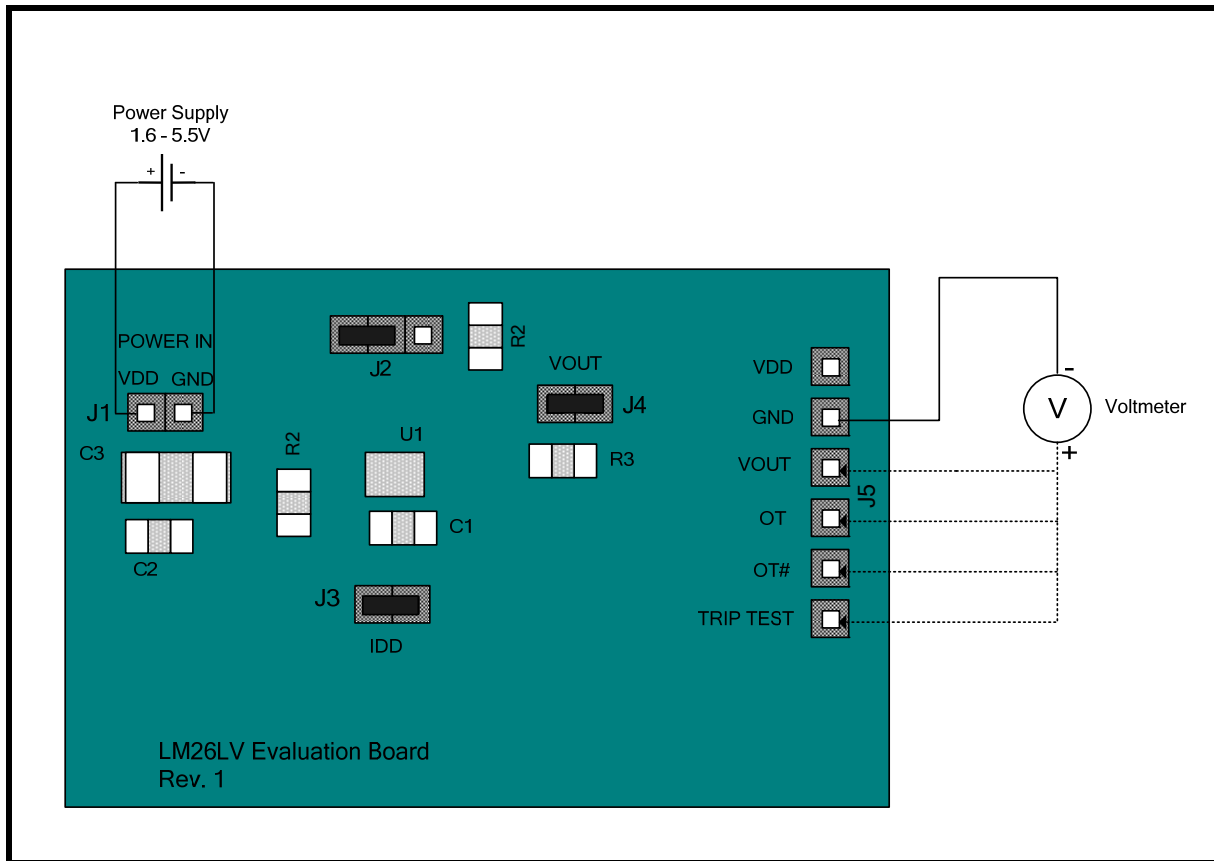

**FIGURE 2.1 Quick Start Diagram – basic functionality test**

### 3.0 Functional Description

Table in section 3.1 outlines the complete functionality of the LM25LV Evaluation Board.

For details of device operation, TRIP TEST function, and output transfer function please see the LM26LV Data Sheet.

### 3.1 LM26LV Evaluation Board Connection Table

Header Label	Header Name	Pin	Description
J1	POWER IN	2	VDD Supply +1.6 to 5.5 VDC
		1	GND This is Power Supply return for VDD Input
J2		<b>1-2</b>	DUT drives VOUT to the level representative of the ambient temperature (DEFAULT)
		2-3	DUT drives VOUT to the pre-programmed level representative of trip temperature
J3	IDD	<b>1-2</b>	Jumper is installed (DEFAULT)
		ammeter	Measure IDD
J4	VOUT	<b>1-2</b>	Jumper is installed across pins 1 and 2 by default. Otherwise resistor R3 is in series with the DUT output.
		Open Circuit	VTEMP drives VOUT through R3, improves stability when VOUT has heavy capacitive load
J5		VDD (1)	VDD test point
		GND (2)	GND test point
		VOUT (3)	DUT VTEMP test point
		OT (4)	DUT OVERTEMP alarm test point
		OT# (5)	DUT OVERTENP# (open drain) alarm test point
		TRIP TEST (6)	DUT TRIP TEST input test point

**TABLE 3.1 Evaluation Board connectivity/functionality – default jumper positions are indicated in BOLD font**

## 4.0 Electrical and Mechanical Specifications

### 4.1 Electrical Specifications

Power Requirements	
The Board uses the +1.6 VDC to +5.5 VDC and GND lines from an external low-noise power supply.	+1.6 VDC to +5.5 VDC

### 4.2 Electrical Schematic

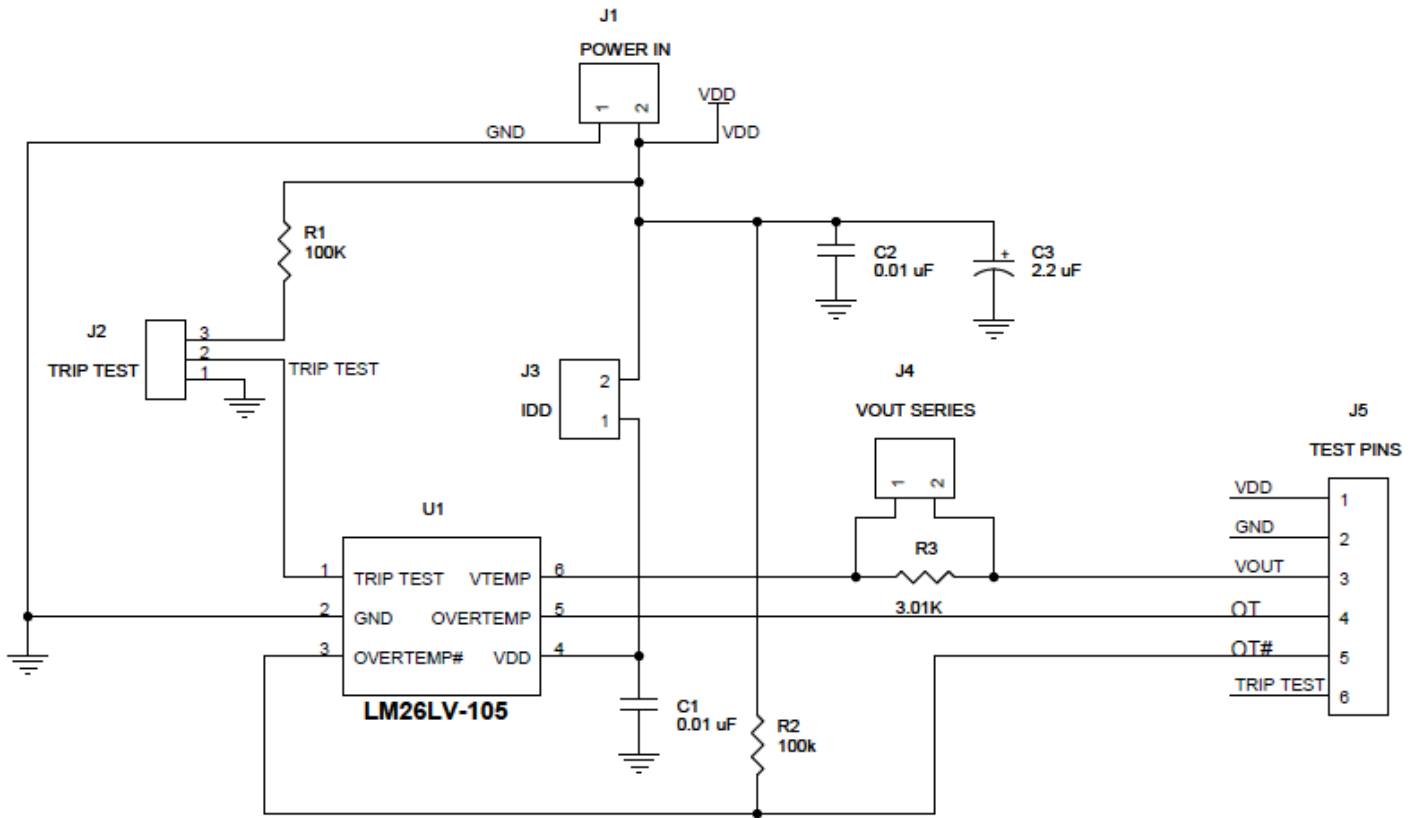

Figure 4.2 Schematic Diagram of the LM26LV Evaluation Board

### 4.3 Evaluation Board Layout

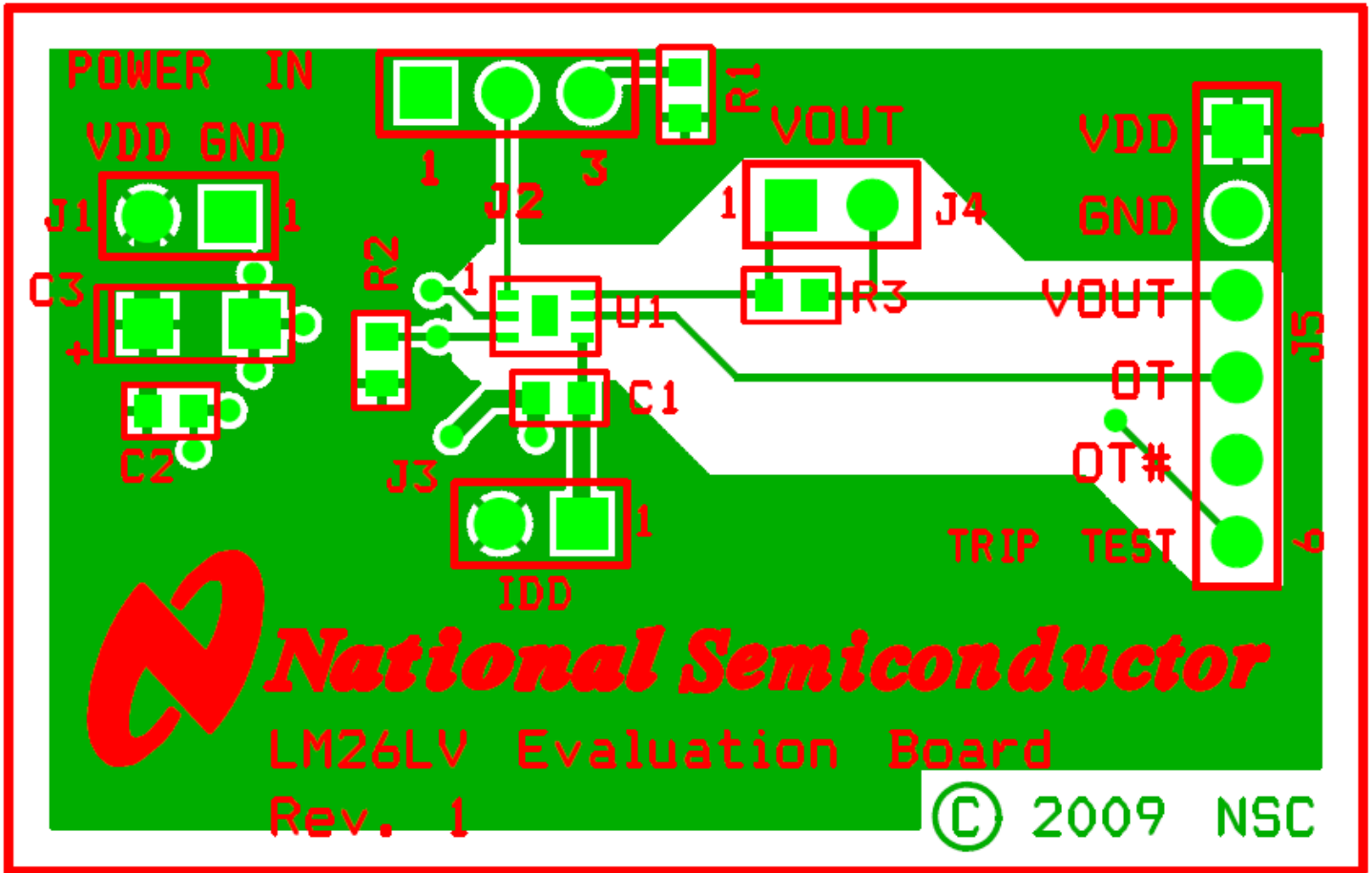

Figure 4.3 Layout diagram of the LM26LV Evaluation Board

#### 4.4 Bill of Materials for LM26LV Evaluation Board

Item	Quantity	Reference	Part
1	2	C1, C2	Capacitor, Ceramic, 0.01 uF
2	1	C3	Capacitor Ceramic, 2.2 uF
3	4	J1, J2, J3, J4	Header, 1X2, 0.1 in centers
4	1	J5	Header, 1X6, 0.1 in centers
6	2	R1, R2	Resistor, 100k
7	1	R3	Resistor, (not stuffed)
8	1	U1	LM26LVCISD-105 Device Under Test (DUT)
9	1	--	Circuit Board, Fabricated, LM26LVEB Evaluation Board, Rev. 1

#### 4.5 Mechanical Specifications

##### 4.5.1 Operating Mechanical and Environmental Specifications

	Minimum	Typical	Maximum
Temperature	0°C	25°C	70°C

##### 4.5.2 Evaluation Board Basic Dimensions

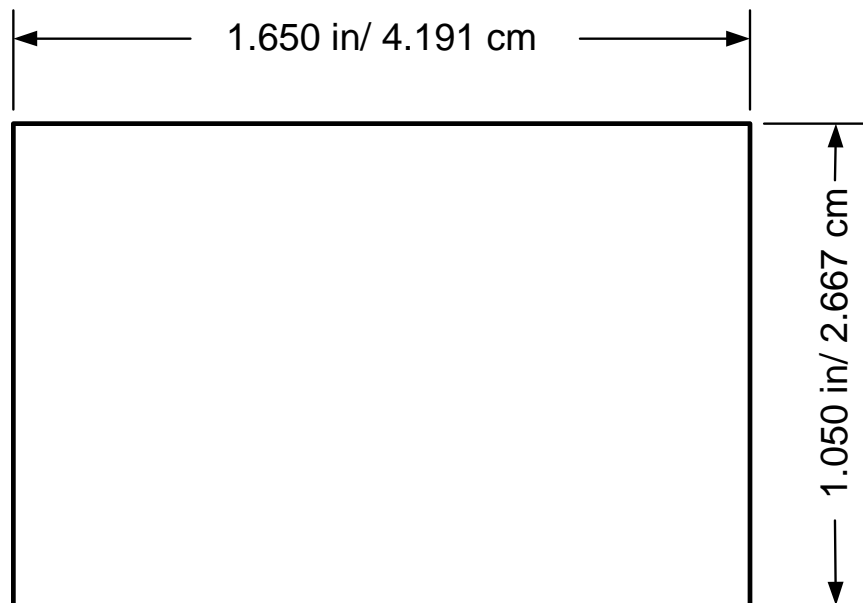

##### 4.5.3 Electrostatic Discharge (ESD) Precautions

The user shall use ESD precautions as specified in National Semiconductor ESD document (SC)CSI-3-038 available through [www.national.com](http://www.national.com).

**BY USING THIS PRODUCT, YOU ARE AGREEING TO BE BOUND BY THE TERMS AND CONDITIONS OF NATIONAL SEMICONDUCTOR'S END USER LICENSE AGREEMENT. DO NOT USE THIS PRODUCT UNTIL YOU HAVE READ AND AGREED TO THE TERMS AND CONDITIONS OF THAT AGREEMENT. IF YOU DO NOT AGREE WITH THEM, CONTACT THE VENDOR WITHIN TEN (10) DAYS OF RECEIPT FOR INSTRUCTIONS ON RETURN OF THE UNUSED PRODUCT FOR A REFUND OF THE PURCHASE PRICE PAID, IF ANY.**

The LM94022 Evaluation Boards are intended for product evaluation purposes only and are not intended for resale to end consumers, are not authorized for such use and are not designed for compliance with European EMC Directive 89/336/EEC, or for compliance with any other electromagnetic compatibility requirements.

National Semiconductor Corporation does not assume any responsibility for use of any circuitry or software supplied or described. No circuit patent licenses are implied.

## **LIFE SUPPORT POLICY**

**NATIONAL'S PRODUCTS ARE NOT AUTHORIZED FOR USE AS CRITICAL COMPONENTS IN LIFE SUPPORT DEVICES OR SYSTEMS WITHOUT THE EXPRESS WRITTEN APPROVAL OF THE PRESIDENT OF NATIONAL SEMICONDUCTOR CORPORATION. As used herein:**

1. Life support devices or systems are devices or systems which, (a) are intended for surgical implant into the body, or (b) support or sustain life, and whose failure to perform, when properly used in accordance with instructions for use provided in the labeling, can be reasonably expected to result in a significant injury to the user.
2. A critical component is any component in a life support device or system whose failure to perform can be reasonably expected to cause the failure of the life support device or system, or to affect its safety or effectiveness.

### **BANNED SUBSTANCE COMPLIANCE**

National Semiconductor certifies that the products and packing materials meet the provisions of the Customer Products Stewardship Specification (CSP-9-111C2) and the Banned Substances and Materials of Interest Specification (CSP-9-111S2) and contain no "Banned Substances" as defined in CSP-9-111S2.



**National Semiconductor Corporation**  
**Americas Customer Support Center**  
Tel: 1-800-272-9959  
Email: [new.feedback@nsc.com](mailto:new.feedback@nsc.com)

**National Semiconductor Europe Customer Support Center**  
Fax: +49 (0) 1 80-530 85 86  
Email: [europe.support@nsc.com](mailto:europe.support@nsc.com)  
Deutsch Tel: +49 (0) 699508 6208  
English Tel: +49 (0) 870 24 0 2171  
Français Tel: +49 (0) 141 91 8790

**National Semiconductor Asia Pacific Customer Support Center**  
Email: [ap.support@nsc.com](mailto:ap.support@nsc.com)

**National Semiconductor Japan Customer Support Center**  
Tel: 81-3-5639-7560  
Fax: 81-3-5639-7507  
Email: [jpn.feedback@nsc.com](mailto:jpn.feedback@nsc.com)

National does not assume any responsibility for any circuitry described, no circuit patent licenses are implied and National reserves the right at any time without notice to change said circuitry and specifications.