

# **DS91M125**

## **125 MHz 1:4 M-LVDS Repeater with LVDS Input Evaluation Kit**

# ***USER MANUAL***

**Part Number: DS91M125EVK NOPB**

For the latest documents concerning these products and evaluation kit, visit [lvds.national.com](http://lvds.national.com). Schematics and gerber files are also available at [lvds.national.com](http://lvds.national.com)

## Overview

The purpose of this document is to familiarize you with the DS91M125 evaluation board, suggest the test setup procedures and instrumentation, and to guide you through some typical measurements that will demonstrate the performance of the device. The board enables the user to examine performance and all functions of the DS91M125 as a standalone device.

The DS91M125 is a high-speed 1:4 M-LVDS repeater with an LVDS input designed for multipoint applications with multiple drivers or receivers. The device conforms to TIA/EIA-899 standard. It utilizes M-LVDS technology for low power, high-speed and superior noise immunity.

## Description

Figure 1 below represents the top layer drawing of the board with the silkscreen annotations. It is a 2.5 x 3 inch 4 layer printed circuit board (PCB) that features a single DS91M125 (U2) device.

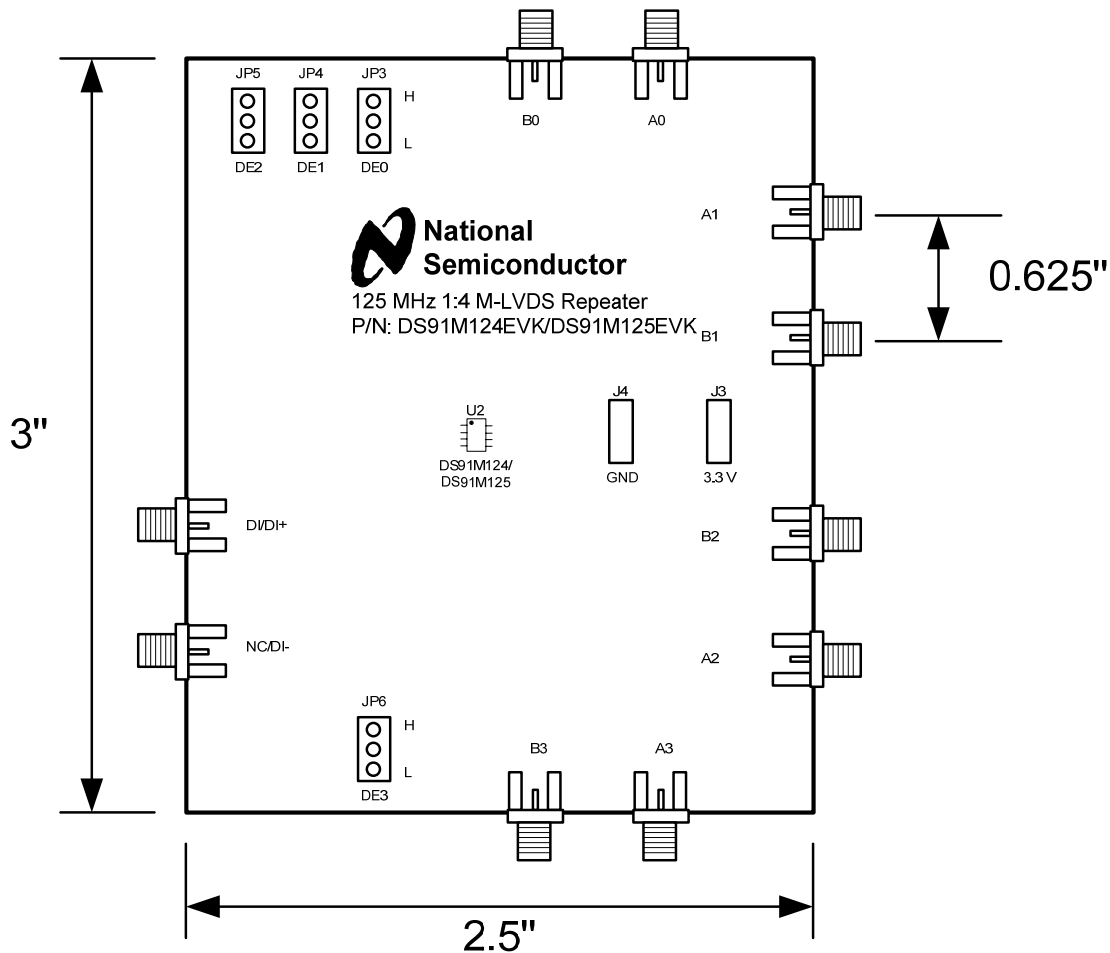
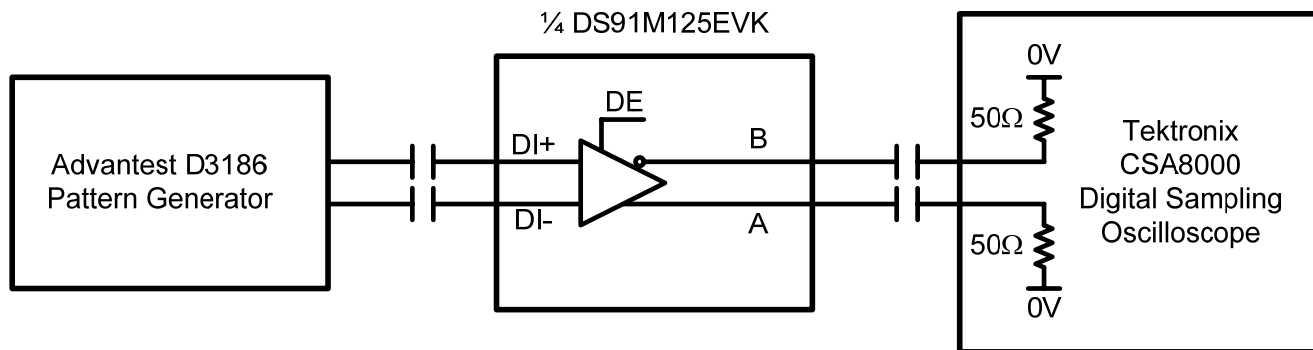

Figure 1 - DS91M125EVK Top View Drawing

## DS91M125 Evaluation in a Point-to-Point Link

The following is a recommended procedure for using and evaluating the DS91M125EVK. Figure 2 depicts a typical setup and instrumentation used.

1. Select a single DS91M125 evaluation board.
2. Apply the power to the board (3.3 V typical) between J3 and J4 power tabs, observe the value of  $I_{CC}$ , and compare it with the expected value (refer to the datasheet) to ensure that the devices are functional.
3. Enable one of the U2 driver outputs. This is accomplished by setting the DE0-3 pin to VDD (JP3-6).
4. Connect a signal source to the driver input (DI+, DI-). The signal needs to be an LVDS/M-LVDS/CML/LVPECL compliant signal. Refer to the DS91M125 datasheet for the receiver input compatibility.
5. Connect one of the U2 outputs (A0-3/B0-3) to an oscilloscope and observe the waveforms.



**Figure 2 – DS91M125 Test Setup**

Figure 3 shows an eye diagram acquired at the output of the DS91M125 driver loaded with a 100-ohm resistor. The generator connected to the driver input simulated a 100 Mbps PRBS-7 NRZ.

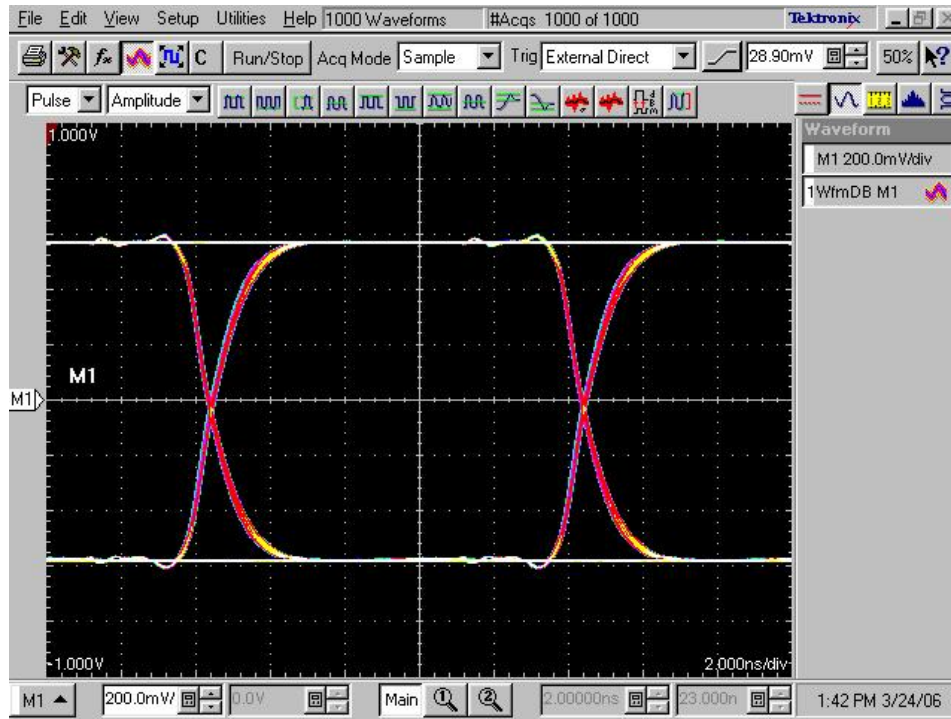

**Figure 3 – DS91M125 Output**



6

5

4

3

2

1

REVISION RECORD			
LTR:	ECO NO:	APPROVED:	DATE:
0	INITIAL RELEASE		

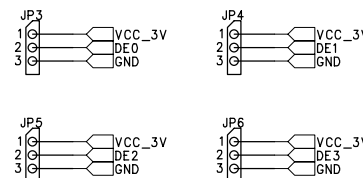
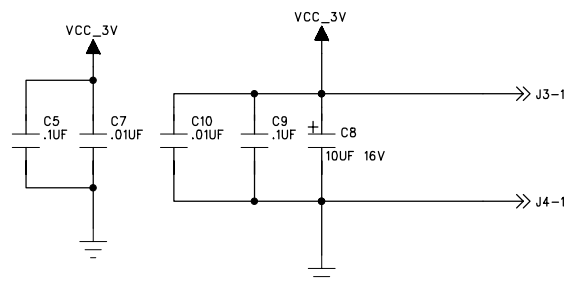
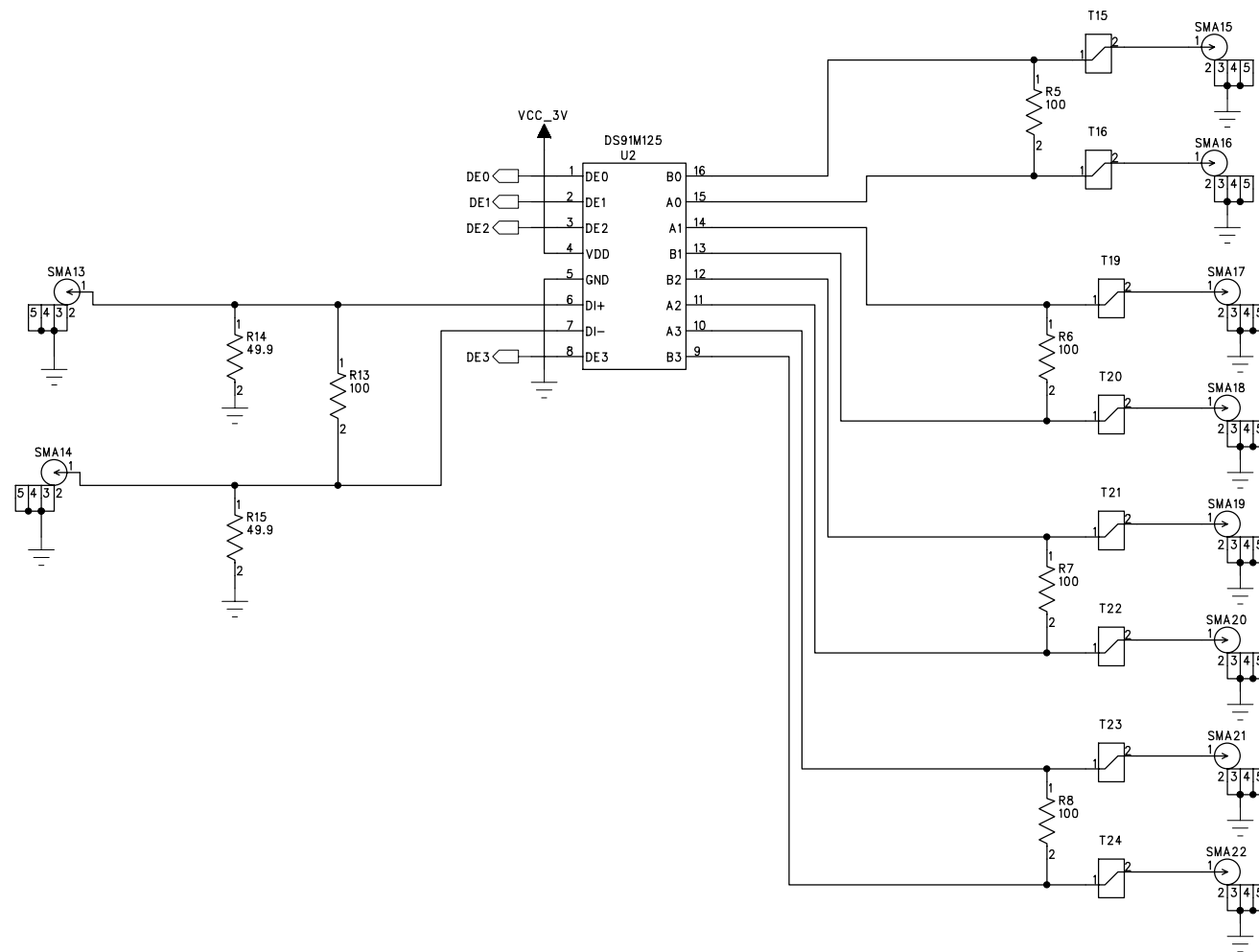

COMPANY:	NATIONAL SEMICONDUCTOR		
TITLE:	SCHEMATIC DS91M047EVK/DS91M124EVK/DS91M125EVK		

 25 NorthBrook Drive Gray, Maine 04039 U.S.A.	CODE:	SIZE:	DRAWING NO:	REV:
		C	S-6539	0
DRAWN: ACF	DATED: 3/11/08	SCALE:		SHEET: 2 OF 2

<b>ENERCON - BILL OF MATERIALS</b>	TITLE: <b>NATIONAL SEMICONDUCTOR PCBA, DS91M125EVK, ROHS DS91M125</b>	PL Number: <b>Z3252-01</b>	Rev: <b>1</b>	Rev By: <b>BJ</b>	Rev Date: <b>04/30/08</b>	PL Status: <b>Released</b>
		Responsible Eng/Mgr: <b>Arlene Fox</b>		Creator: <b>Arlene Fox</b>		Creation Date: <b>03/14/08</b>
Main Product: <b>PCBA, DS91M125EVK, ROHS</b>						

Item	Part Type	Part Number/Value	Mfg	NoSub	Description	Qty	SMT	Ref Des	Notes	Rev
1	PCB	P-06540R0	ENERCON			1				0
2										
3	SUBASY	Z3211-04	ENERCON		LABEL, MADE IN U.S.A.	1			Apply to bottom of PCBA	1
4										
5	IC	DS91M125TMA	NAT		125MHz 1:4 M-LVDS Repeater, SOIC16	1	X	U2		0
6										
7	RES	ERJ-2RKF1000	PANA		100 Ohm 1/16W ±1% 0402 100ppm, Pb-Free	1	X	R13		0
8										
9	CAP	06035C103KAT	AVX		.01µF, 50V, ±10%, 0603, Ceramic, X7R, Pb-Free	2	X	C7,10		0
10	CAP	0603YC104KAT	AVX		.1µF, 16V, ±10%, 0603, Ceramic, X7R, Pb-Free	2	X	C5,9		0
11	CAP	TAJA106K016	AVX		10µF, 16V, ±10%, A-Case, Tantalum, Pb-Free	1	X	C8		0
12										
13	CONN	1287	KEYSTONE		Faston, Male, .250", Pb-Free	2		J3,4		0
14	CONN	142-0701-851	EMERSON		SMA, Jack Receptacle, 50 OHM, Pb-Free	10		SMA13-22		0
15	CONN	15-29-1024	MOLEX		Jumper Shunt, 2p, Gold, Pb-Free	4			Use on JP3,4,5,6 Pins 2&3	0
16	CONN	TSW-103-07-G-S	SAMTEC		Header, 3p, Male, .100"sp, Gold, Pb-Free	4		JP3,4,5,6		0
17										
18	STENCL	T-06544R0	ENERCON		STENCIL FABRICATION, BOTTOM, DS91M047EVK/DS91M1...	1				0
19										
20	REF	C-06541R0	ENERCON		FAB DWG, DS91M047EVK/DS91M124EVK/DS91M125EVK					0
21	REF	C-06542R0	ENERCON		PALLET DWG, DS91M047EVK/DS91M124EVK/DS91M125EVK					0
22	REF	S-06539R0	ENERCON		SCHEMATIC, DS91M047EVK/DS91M124EVK/DS91M125EVK					0
23										

<b>ENERCON - BILL OF MATERIALS</b>	TITLE: <b>NATIONAL SEMICONDUCTOR PCBA, DS91M125EVK, ROHS DS91M125</b>	PL Number: <b>Z3252-01</b>	Rev: <b>1</b>	Rev By: <b>BJ</b>	Rev Date: <b>04/30/08</b>	PL Status: <b>Released</b>
		Responsible Eng/Mgr:		Creator: <b>Arlene Fox</b>		Creation Date: <b>03/14/08</b>
Main Product: <b>PCBA, DS91M125EVK, ROHS</b>						

Notes:

**DO NOT STUFF:**

**U1**

**M1-10**

**JP1,2**

**R1-12,14,15**

**T1-2,7,15,17,19,21,23,3,11,12,16,18,20,22,24**

**J1,2**

**C1,2,3,4,6**

**SMA1-12**



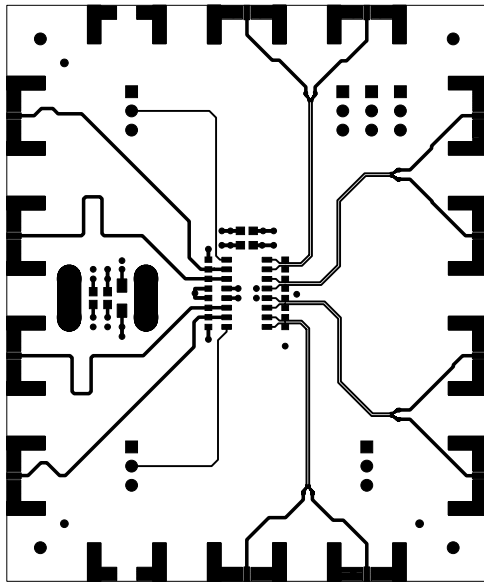

-  
TOP

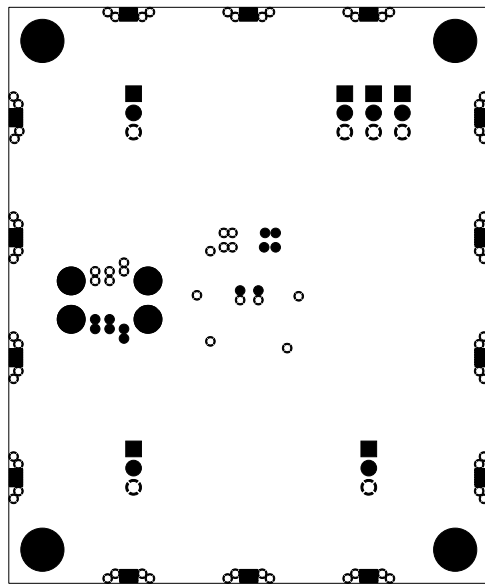

-  
LAYER 2

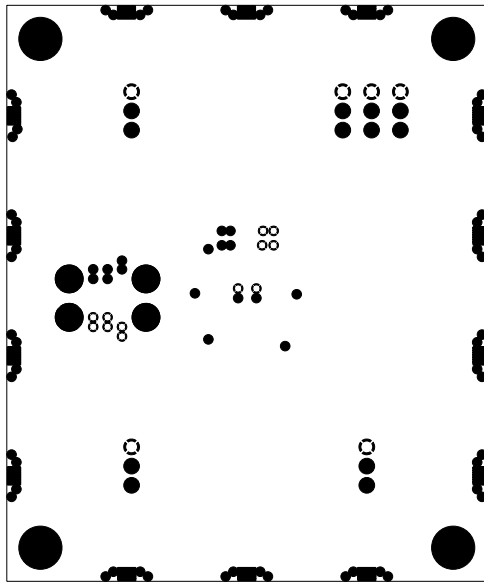

LAYER 3

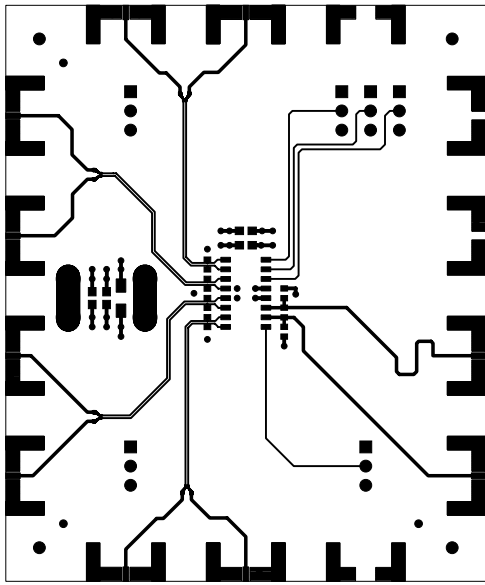

BOTTOM

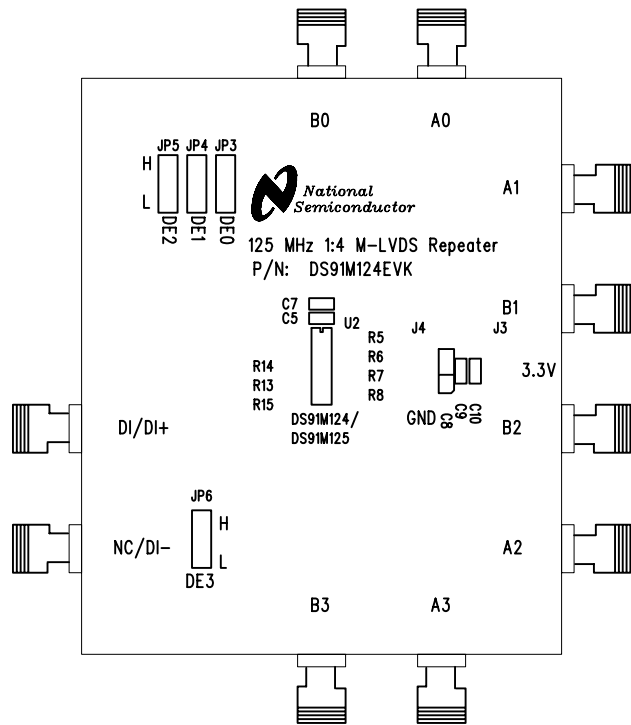

SILKSCREEN BOTTOM

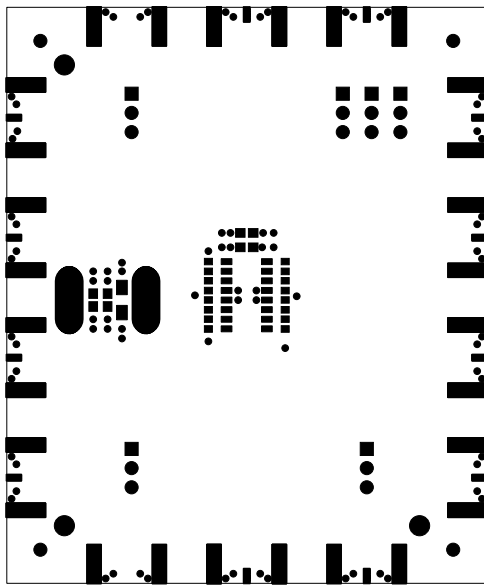

-  
SOLDERMASK TOP

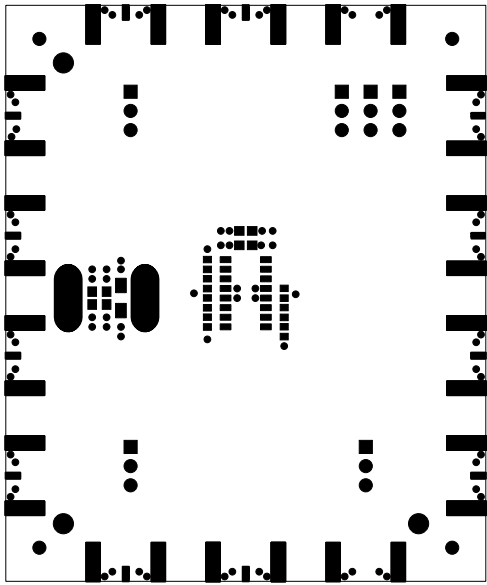

20LDERMA3K BOTTOM

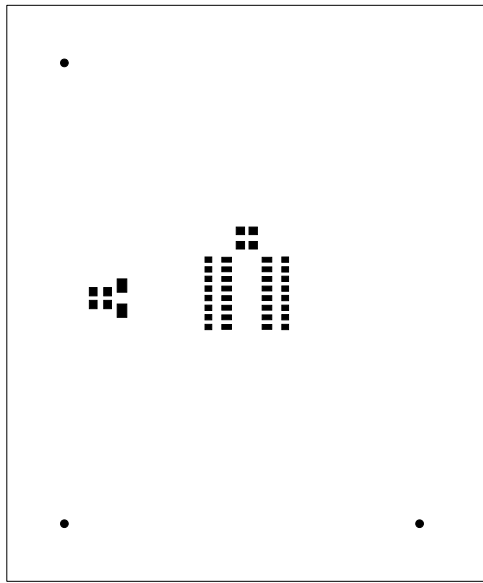

-  
SOLDERPASTE TOP  
SQUEEGEE VIEW

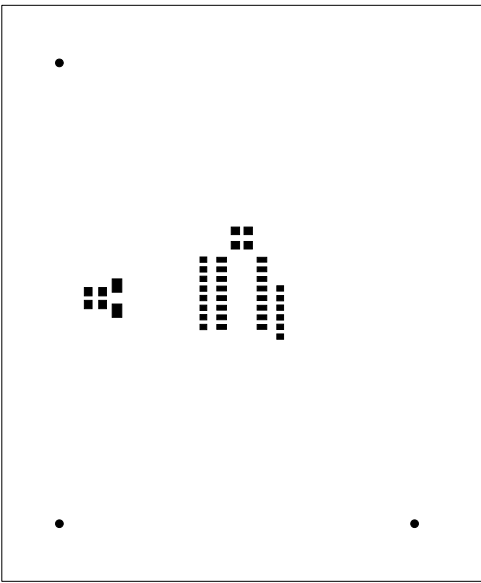

SOLDERPASTE BOTTOM