

# DS90UR908Q-EVK

## FPD-Link II to FPD-Link Converter

### Evaluation Kit

Rev 0.1  
May, 2010

---

#### General Description

The DS90UR908Q-EVK converts FPD-link II to FPD-Link. It translates a high-speed serialized interface with an embedded clock over a single pair to four LVDS data/control streams and one LVDS clock pair. It is backward compatible for operation with older generation deserializer devices.

The DS90UR908Q-EVK board has a space saving 20-position wall header as the FPD-Link output, and a Rosenberger Automotive HSD Connector as the input. USB or SMA connectors can also be configured as the input, based on the type of the cable to be used.

#### Features

- 5 – 65 MHz support (140 Mbps to 1.82 Gbps Serial Link)
- 5-channel (4 data + 1 clock) FPD-Link driver outputs
- AC Coupled STP Interconnect up to 10 meters in length
- Integrated input termination
- @ Speed link BIST Mode and reporting pin
- Optional I2C compatible Serial Control Bus
- RGB888 + VS, HS, DE converted from 1 pair
- Power down mode minimizes power dissipation
- FAST random data lock; no reference clock required
- Adjustable input receive equalization
- LOCK (real time link status) reporting pin
- Low EMI FPD-Link output
- SSCG option for lower EMI
- 1.8V or 3.3V compatible I/O interface
- Automotive grade product: AEC-Q100 Grade 2 qualified
- >8kV HBM ESD tolerance
- Backward compatible mode for operation with older generation devices

#### Applications

- Automotive Displays for Navigation
- Automotive Display for Entertainment

#### Ordering Information

**PART:** DS90UR908QSQ  
**Demo board:** DS90UR908Q-EVK  
[national.com](http://national.com)

1



© National Semiconductor Corporation 2009



Printed in U.S.

## Typical Configuration

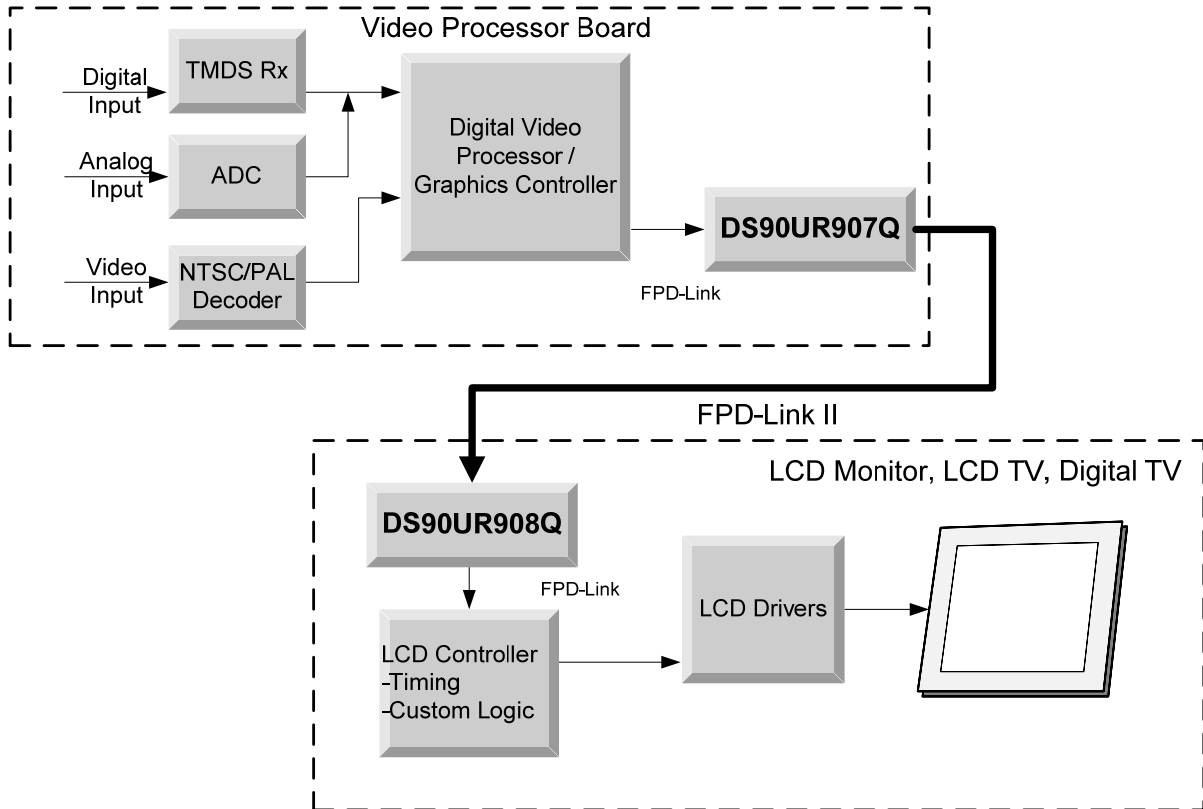

### Quick Start Guide:

1. Connect 3.3V DC power and ground of the board to the JP1 from the power supply. Connect 1.8V DC power and ground of the board to the J4 and J5 from the power supply.
2. Attach an applicable cable (not supplied) to this RX board (DS90UR908) input from a TX board (DS90UR907) output.
3. From the Video Decoder board, connect a flat cable (not supplied) to the TX board and connect another flat cable (not supplied) from this RX board to the panel.
4. Jumpers and switches have been configured at the factory; they should not require any changes for immediate operation of the board. See text on Configuration Settings and datasheet for more details.

## Configuration Settings

Component	Name	Function
<b>Power Connections</b>		
J7	5V DC	Optional 5V DC Power Jack.
J4	1.8V DC	1.8V VDD Power.
JP1	3.3V DC	3.3V VDD Power.
J5	VSS	Ground.
JP2	VDDIO	Connect to 3.3V or 1.8V.
JP3	VDDA2	Always connect to 1.8V.
-	VDDPC	Always connect to 1.8V.
-	VDDL	Always connect to 1.8V.
-	VDDTXC	Always connect to 3.3V.
<b>Input and Output Connections</b>		
J8	20 position wall header	Connect to FPD-Link output.
J1	Automotive HSD Connector	Connect to FPD-Link II input (default).
J9 and J10	SMA Connector	Connect to FPD-Link II input. (When using these connectors, R3 and R4 should be placed with 0Ω resistors, the traces from R3 and R4 to the J1 should be cut).
J2	USB Connector	Connect to FPD-Link II input. (When using this connector, P1 should be removed, and R24 and R25 should be placed with 0Ω resistors)
JP12 and JP13	Power Wire in USB cable through J2	Connect to VSS is recommended.
<b>Control Connections</b>		
JP4	TESTEN	NSC test mode. Always connect it to "L" or leave it unconnected.
JP5	LF_MODE	Connect to "L" or "H" for the PCLK frequency select. See datasheet for detail information.
JP6	OSSEL	Connect to "L" or "H" for the Output State select. See datasheet for detail information.
JP7	MAPSEL	Connect it to "L" or "H" for the FPD Link mapping select. See datasheet for detail information.
JP8	VODSEL	Connect it to "L" or "H" for the FPD-Link VOD level select. See datasheet for detail information.
JP9	OEN	Connect it to "L" or "H" for the Output Enable select. See datasheet for detail information.
JP10	BISTEN	Connect it to "H" for the BIST enable mode. See datasheet for detail information.
-	PDB	Connect it to "L" for the power down mode. Connect it to "H" for the enable mode. See datasheet for detail information.
-	SSC[2:0]	Connect them to "L" or "H" for the SSCG selection.
-	CONFIG	Configuration select. See datasheet for detail information.
JP24 and VR3	ID[x]	Connect JP24 to VSS to have the default device PHY address (h'DC). Connect JP24 to VR3; then adjust VR3 value to select desired device PHY address. See datasheet for detail information.
J3 and JP23	I2C Interface	Connect JP23 if the I2C power is not supplied on J6. Otherwise, leave it unconnected.
<b>Others</b>		
LED1	PASS	PASS output. "ON" when PASS is "H"
LED2	LOCK	LOCK output. "ON" when LOCK is "H"
JP11, JP25, JP26	Other options	Do not connect

## Bill of Material

Item	Quantity	Reference	Part	Comments	Digi-Key P/N	Part Number
1	2	C3,C4	0.1uF	CAP CERAMIC .1UF25V X5R 0402	445-4964-1-ND	C1005X5R1E104K
2	1	C5	4.7uF	CAP .1UF 16V CERAMIC Y5V 0402.	PCC1731CT-ND	ECJ-0EF1C104Z
3	9	C6,C18,C20,C22,C25,C26, C27,C28,C29	0.01uF	CAP CERAMIC .01UF 100V X7R 0603	399-3189-1-ND	C0603C103K1RACTU
4	10	C7,C17,C19,C21,C23,C24, C30,C31,C32,C35	0.1uF	CAP .1UF 0% 25V CERAMIC X7R 0603	PCC2277CT-ND	ECJ-1VB1E104K
5	2	C10,C13	22uF	CAP TANTALUM 22UF 25V 20% SMD	493-2391-1-ND	F931E226MNC
6	2	C11,C14	2.2uF	CAPACITOR TANT 2.2UF 20V 10% SMD	399-3714-1-ND	T491B225K020AT
7	2	C12,C15	0.1uF	CAP .10UF 50V CERAMIC X7R 1206	399-1249-1-ND	C1206C104K5RACTU
8	3	C16,C33,C34	22uF	CAPACITOR TANT 22UF 16V 20% SMD	399-3835-1-ND	T494B226M016AT
9	2	JP1,JP23	2-Pin Header	CONN HEADER VERT .100 2POS 30AU	A26542-ND	87220-2
10	24	JP2,JP3,JP4,JP5,JP6,JP7, JP8,JP9,JP10,JP12, JP13,JP14,JP15,JP16,JP17, JP18,JP19,JP20,JP21,JP22, JP24	3-Pin Header	CONN HEADER VERT .100 3POS 15AU	A26545-ND	87224-3
11	1	J2	mini USB 5pin	CONN RECEPT MINI USB2.0 5POS.	H2959CT-ND	UX60-MB-5ST
12	1	J3	IDC1X4	CONN HEADER 4POS .100 VERT GOLD	WM2702-ND	22-11-2042
13	2	J4,J5	BANANA	BANANA-female (non-insulated) CONN HEADER 20 POS STRGHT	J147-ND	108-0740-001
14	1	J8	2X10-Pin Header	GOLD. End Launch Jack Receptacle - Tab	MHC20K-ND	N2520-6002RB
15	2	J9,J10	SMA	Contact.	J658-ND	142-0701-851
16	1	LED1	0402_orange_LED	LED ORN/CLEAR 610NM 0402 SMD	67-1879-1-ND	SML-LX0402SOC-TR
17	1	LED2	0603_green_LED	LED GREEN CLEAR THIN 0603 SMD	160-1446-1-ND	LTST-C191KGKT
18	2	R1,R2	0 Ohm,0402	RES ZERO OHM 1/16W 5% 0402 SMD.	P0.0JTR-ND	ERJ-2GEJ0R00X
19	9	R6,R20,R21,R22,R23,R26, R27,R28,R29	0 Ohm,0402	RES ZERO OHM 1/16W 5% 0402 SMD	P0.0JTR-ND	ERJ-2GEJ0R00X
20	1	R7	10K	RES 10.0K OHM 1/10W 1% 0402 SMD	P10.0KHCT-ND	ERJ-3EKF1002V
21	2	R10,R11	82.5ohm	RES 82.5 OHM 1/10W 1% 0603 SMD	P82.5HCT-ND	ERJ-3EKF82R5V
22	5	R13,R14,R15,R16,R17	100	RES 100 OHM 0201 SMD. 1/20W .5%	RR03P100DCT- ND	RR0306P-101-D
23	2	R31,R32	4.7K	RES 4.7K OHM 1/10W 5% 0603 SMD	P4.7KGCT-ND	ERJ-3GEYJ472V
24	1	U1	DS90UR908	11-Turn Trimming Potentiometer; Top Adjust	3224W-1- 104ECT-ND	DS90UR908
25	1	VR3	SVR100K			3224W-1-104E

# Schematics

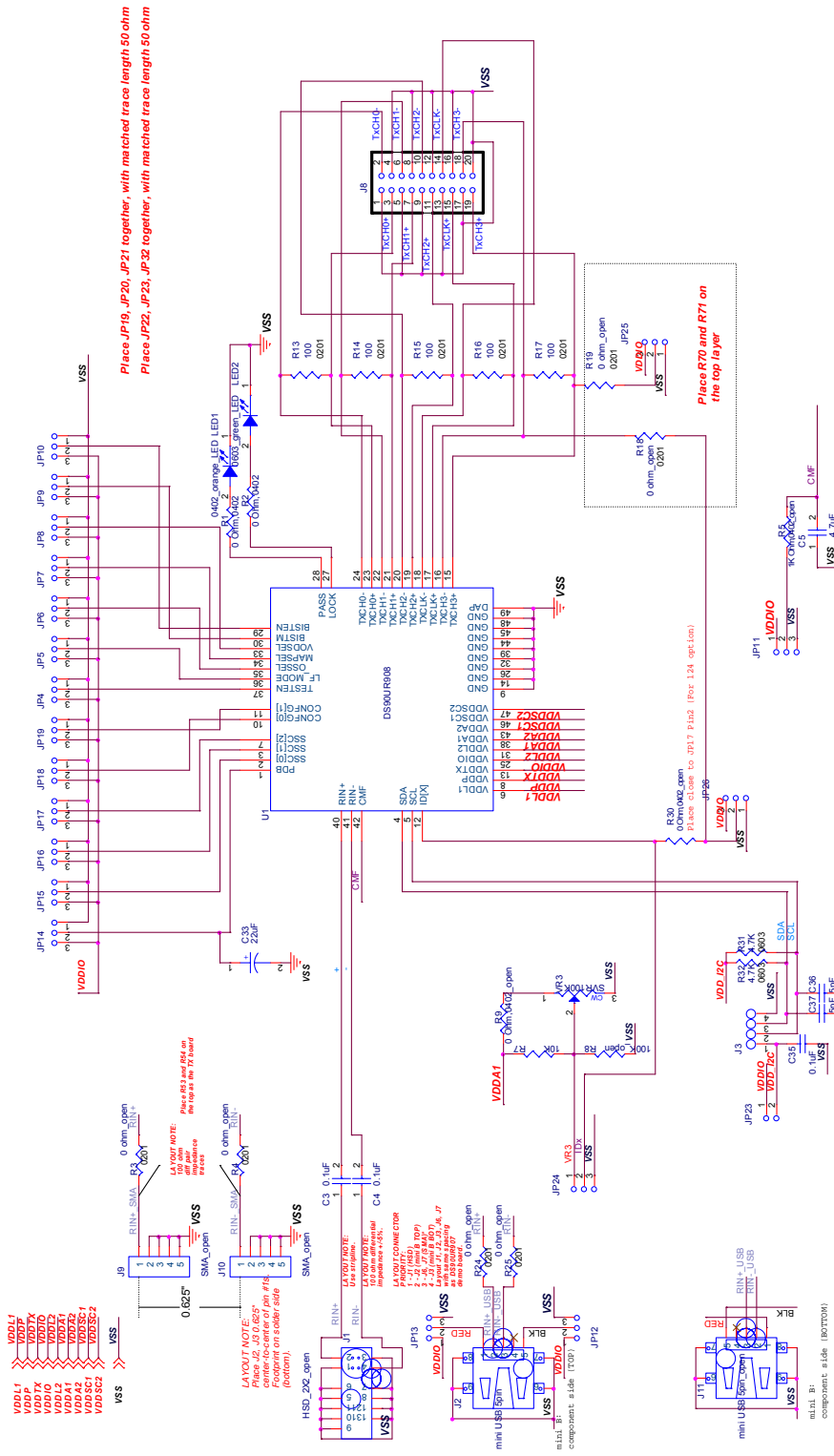



# Reference Layout

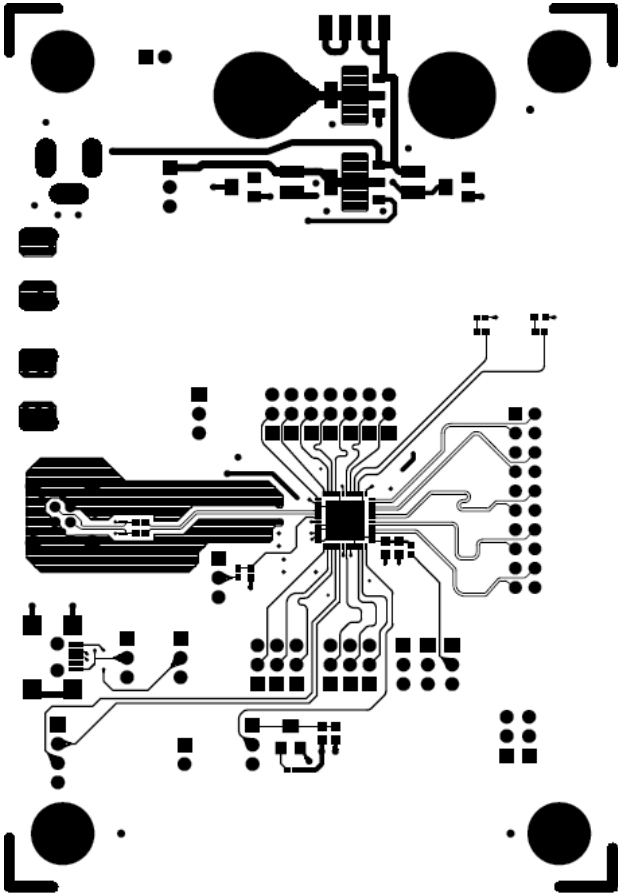

Top Layer

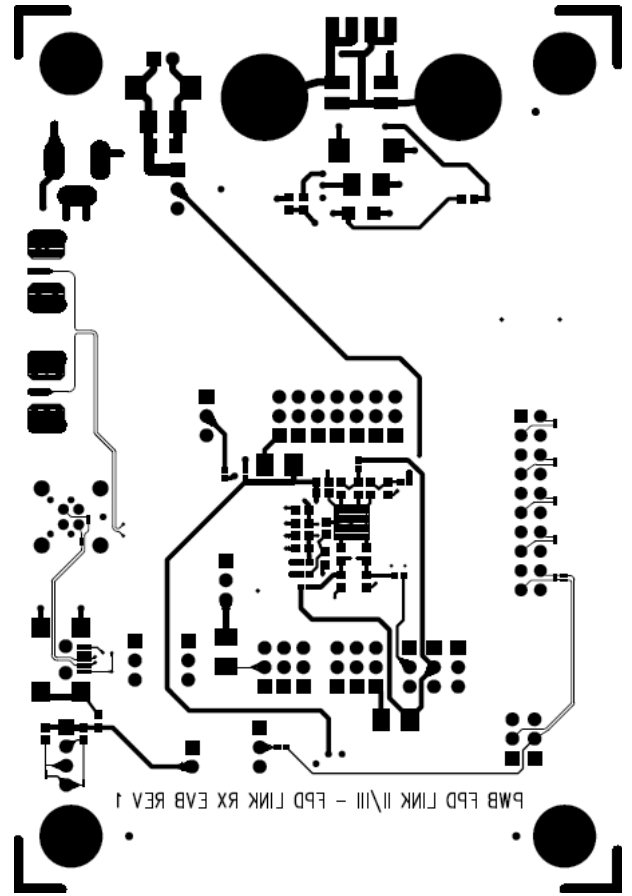

Bottom Layer