

**CONFIDENTIAL**

National Semiconductor Corporation

Reproduction or disclosure without written authorization from National Semiconductor Corporation is strictly PROHIBITED.

Title		
DsPhyter II DP83847 Mau Demo2 Cover		
Size	Document Number	Rev
B	870011498-200	A
Date:	Wednesday, July 25, 2001	Sheet 1 of 4
	2	1

Auto-Negotiation Straps

AN_EN	AN1	AN0	Description
0	0	0	10Mbps HD Force
0	0	1	10Mbps FD Force
0	1	0	100Mbps HD Force
0	1	1	100Mbps FD Force
1	0	0	10Mbps H/FD Advertised
1	0	1	100Mbps H/FD Advertised
1	1	0	10/100Mbps HD Advertised

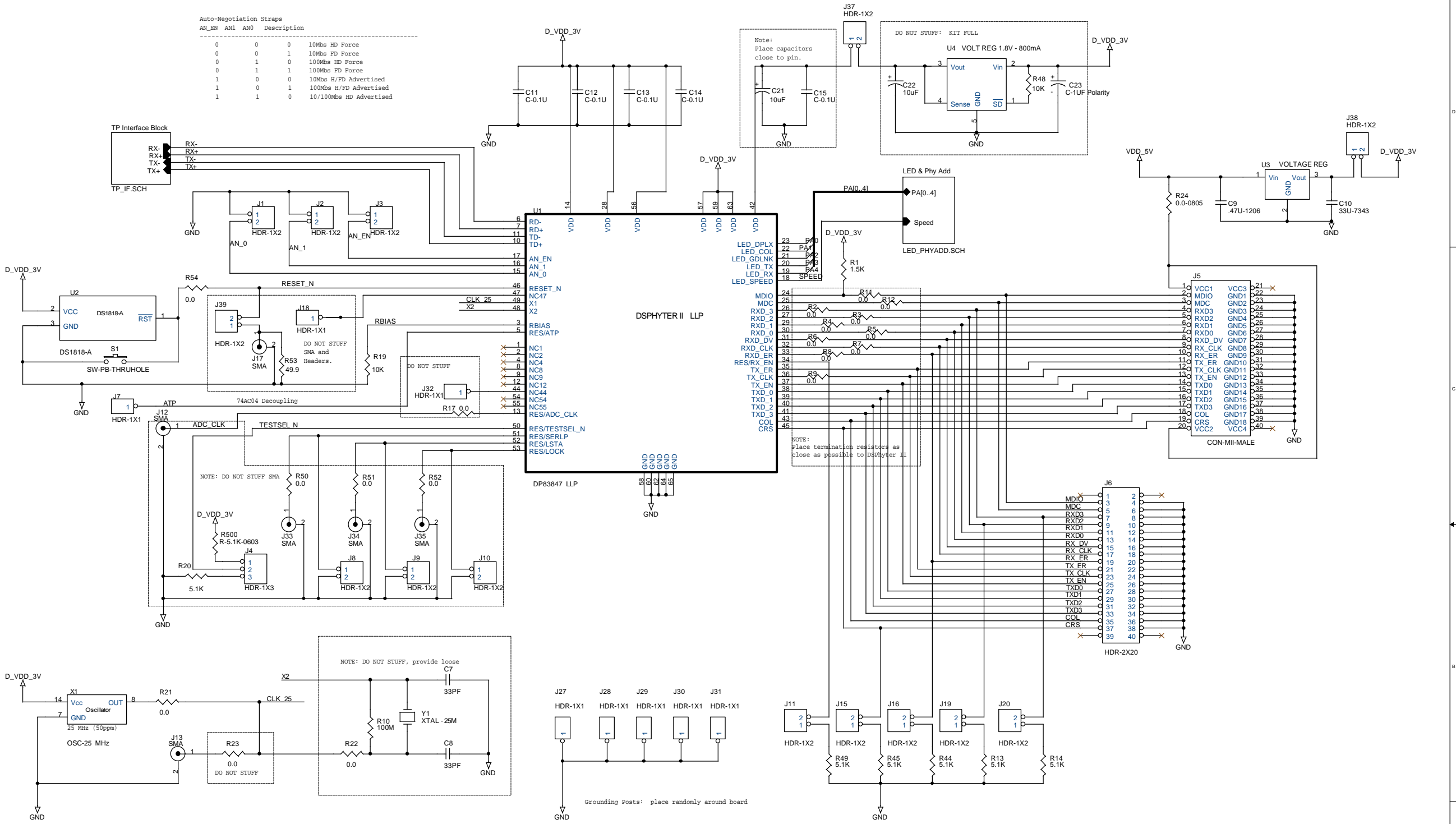

**CONFIDENTIAL**  
National Semiconductor Corporation

Reproduction or disclosure without written authorization from National Semiconductor Corporation is strictly PROHIBITED.

Title DsPhyter II DP83847 Mau Demo2		
Size C	Document Number 870011498-200	Rev A
Date: Wednesday, July 25, 2001	Sheet 2	of 4

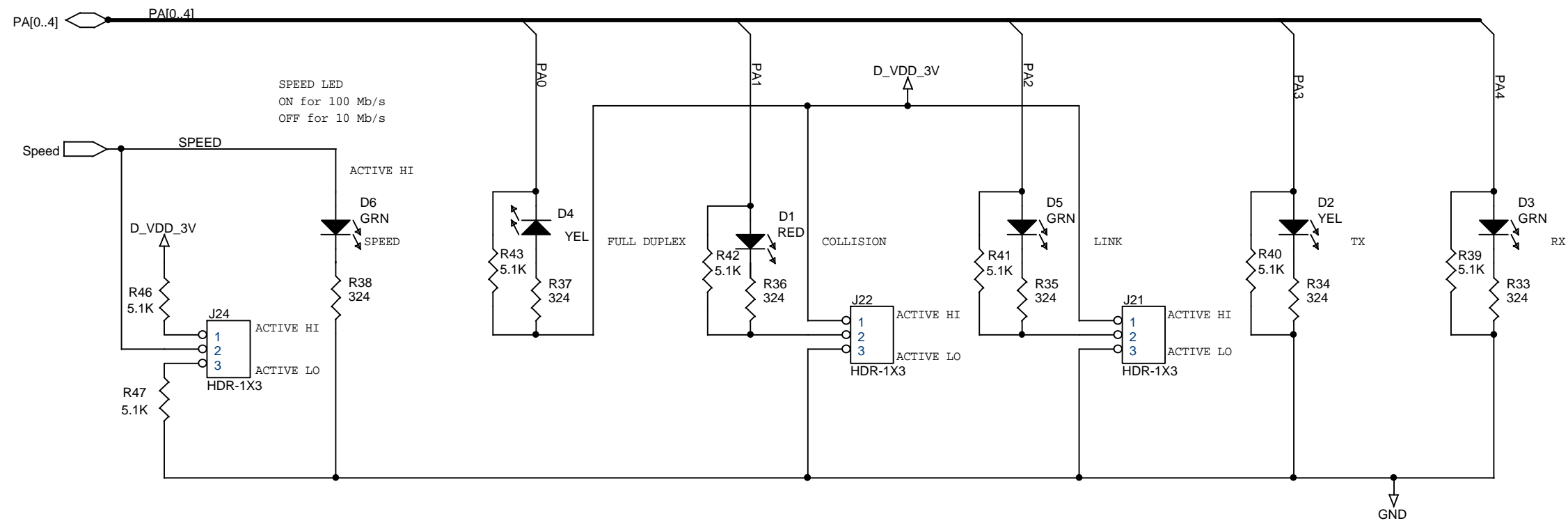

Phy Address Strap

J22	J21	Address
2-3	2-3	1

**CONFIDENTIAL**

National Semiconductor Corporation

Reproduction or disclosure without written authorization from National Semiconductor Corporation is strictly PROHIBITED.

Title		
DsPhyter II DP83847 Mau Demo2 LED & Phy Addr Config		
Size	Document Number	Rev
B	870011498-200	A
Date:	Wednesday, July 25, 2001	Sheet 3 of 4
	2	1

