

Figure 1. ADC14V155 Evaluation Board Connector and Jumper Locations

1.0 Introduction

The ADC14V155 Evaluation Board is designed to support the ADC14V155 14-bit 155 Mega Sample Per Second (MSPS) Analog to Digital Converter with LVDS Outputs.

The ADC14V155 Evaluation Board comes in two versions:

1. ADC14V155HFEB (high frequency version) for input frequencies greater than 150 MHz.
2. ADC14V155LFEB (low frequency version) for input frequencies less than 150 MHz.

The digital data from the ADC14V155 evaluation board can be captured with a suitable instrument, such as a logic analyzer, or with National Semiconductor's WaveVision signal path data acquisition hardware and software platform. The ADC14V155 evaluation board can be connected to the data acquisition hardware through the FutureBus connector (schematic reference designator FB).

The ADC14V155 is compatible with National Semiconductor's WaveVision 5.1 and higher Signal Path Digital Interface Board and associated WaveVision software. Please note that the ADC14V155 board is not compatible with previous versions of the WaveVision hardware (WaveVision 4.x Digital Interface Boards).

The WaveVision hardware and software package allows fast and easy data acquisition and analysis. The WaveVision hardware connects to a host PC via a USB cable and is fully configured and controlled by the latest WaveVision software. The latest version of the WaveVision software is included in this evaluation kit on a CD-ROM. The WaveVision 5.1 Signal Path Digital Interface hardware is available through the National Semiconductor website (part number: WAVEVSN 5.1).

2.0 Board Assembly

Each evaluation board from the factory is configured for single-ended clock operation and is populated with an analog input network which has been optimized for one of two analog input frequencies ranges:

1. ADC14V155HFEB (high frequency version) for input frequencies greater than 150 MHz.
2. ADC14V155LFEB (low frequency version) for input frequencies less than 150 MHz.

Please refer to the input circuit configurations described in the Analog Input Section (4.2) of this guide.

The location and description of the components on the ADC14V155 evaluation board can be found in Figure 1 as well as Section 5.0 (Schematic) and Section 7.0 (Bill of Materials) of this user's guide.

3.0 Quick Start

The ADC14V155 evaluation board enables easy set up for evaluating the performance of the ADC14V155.

If the WaveVision data acquisition and data analysis system is to be used for capturing data, please follow the Quick Start Guide in the WaveVision User's Guide to install the required software and to connect the WaveVision Digital Interface Board to the PC and to the ADC14V155 evaluation board. Please note that the ADC14V155 evaluation board is only compatible with National Semiconductor's WaveVision 5.1 and higher Signal Path Digital Interface boards.

3.1 Evaluation Board Jumper Positions

The ADC14V155 evaluation board jumpers should be configured as follows. Please refer to Figure 1 for the exact jumper locations.

1. **J1** on the reverse of the board should be shorted.
2. The **PD** jumper places the ADC14V155 into either powerdown or sleep mode. Table 1 below shows how to select between the power modes.

| PD Jumper Setting | Mode |
|-------------------|------------------|
| Open | Normal Operation |
| 1-2 | Power-down |
| 3-4 | Sleep |

Table 1. CLK_SEL/DF Selection Table

3. **CLK_SEL/DF** pin jumpers select the output data format (2's complement or offset binary) and clock mode (single-ended or differential). Table 2 below shows how to select between the clock modes and output data formats. Please note that the ADC14V155 evaluation board is delivered with the ADC14V155 clock input configured for single-ended operation and Offset Binary output data format (Jumper 7-8).

| CLK_SEL/DF Jumper Setting | Clock Mode | Output Data Format |
|---------------------------|--------------|--------------------|
| 1-2 | Differential | 2's Complement |
| 3-4 | Differential | Offset Binary |
| 5-6 | Single-Ended | 2's Complement |
| 7-8* | Single-Ended | Offset Binary |

* As assembled from factory.

Table 2. CLK_SEL/DF Selection Table

3.2 Connecting Power and Signal Sources

1. To power the ADC14V155 evaluation board, connect a 5.0V power supply capable of supplying up to 500mA to the green power connector labeled "+5V" which is located along the bottom edge of the ADC14V155 evaluation board.
2. Use the FutureBus connector (FB) to connect the ADC14V155 evaluation board to the instrument being used to capture the data from the evaluation board. If the WaveVision Digital Interface Board is being used for data capture, please consult the WaveVision User's Guide for details on installing and operating the WaveVision hardware and software system.
3. Connect the clock and signal inputs to the CLK_IN_SE and AIN_XX (where XX = HF or LF) SMA connectors.

4.0 Functional Description

4.1 Clock Input

The clock used to sample the analog input should be applied to the CLK_IN_SE SMA connector (if using the single-ended clock mode).

To achieve the best noise performance (best SNR), a low jitter clock source with total additive jitter less than 150 fs should be used. A low jitter crystal oscillator is recommended, but a sinusoidal signal generator with low phase noise, such as the SMA100A from Rohde & Schwarz or the HP8644B (discontinued) from Agilent / Hewlett Packard, can also be used with a slight degradation in the noise performance. When using a low phase noise clock source, the SNR is primarily degraded by the broadband noise of the signal generator. The clock signal generator amplitude is typically set to +19.9 dBm to produce the highest possible slew rate, but the SNR performance will be impacted minimally by lowering the signal generator amplitude slightly. Placing a bandpass filter between the clock source and the CLK_IN_SE SMA connector will further improve the noise performance of the ADC

by filtering out the broadband noise of the clock source. All results in the ADC14V155 datasheet are obtained with a tunable bandpass filter made by Trilithic, Inc. in the clock signal path.

The noise performance of the ADC14V155 can be improved further by making the edge transitions of the clock signal entering the ADC clock input (pin 11, CLK+) very sharp. The ADC14V155 evaluation board is assembled with a high speed buffer gate (NC7WV125K8X, schematic reference designator U2) in the clock input path to provide a sharp clock edge to the clock inputs and improve the noise performance of the ADC. The amplitude of the clock signal from the NC7WV125K8X high speed buffer is 3.3V.

4.2 Analog Input

To obtain the best distortion results (best SFDR), the analog input network on the evaluation board must be optimized for the signal frequency being applied.

For analog input frequencies up to 150 MHz, the circuit in Figure 2 is recommended. This is the configuration of the assembled ADC14V155LFEB as it is delivered from the factory. For input frequencies above 150 MHz, the circuit in Figure 3 is recommended. This is the configuration of the assembled ADC14V155HFEB as it is delivered from the factory.

A low noise signal generator such as the HP8644B is recommended to drive the signal input of the ADC14V155 evaluation board. The output of the signal generator must be filtered to suppress the harmonic distortion produced by the signal generator and to allow accurate measurement of the ADC14V155 distortion performance. A low pass or a bandpass filter is recommended to filter the analog input signal. In some cases, a second low pass filter may be necessary. The bandpass filter on the analog input will further improve the noise performance of the ADC by filtering the broadband noise of the signal generator. Data shown in the ADC14V155 datasheet was taken with a tunable bandpass filter made by Trilithic in the analog signal path.

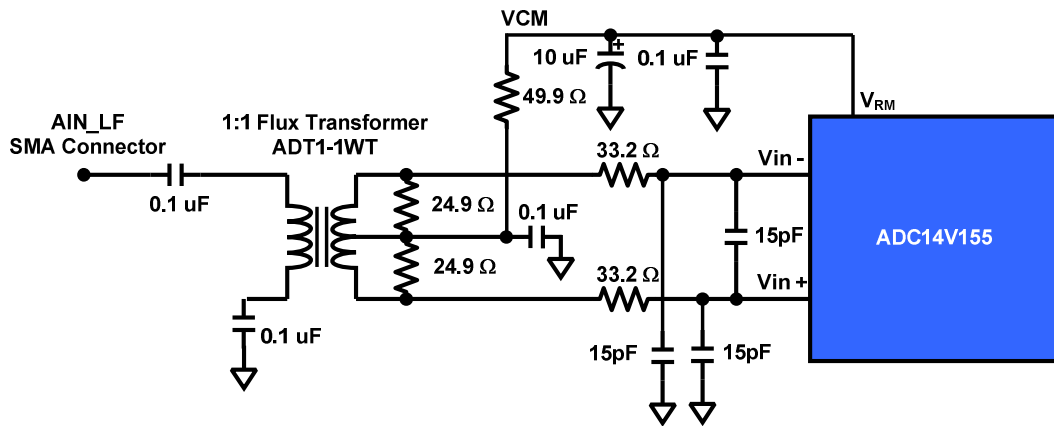

Figure 2. Analog Input Network of ADC14V155LFEB: $F_{IN} < 150$ MHz

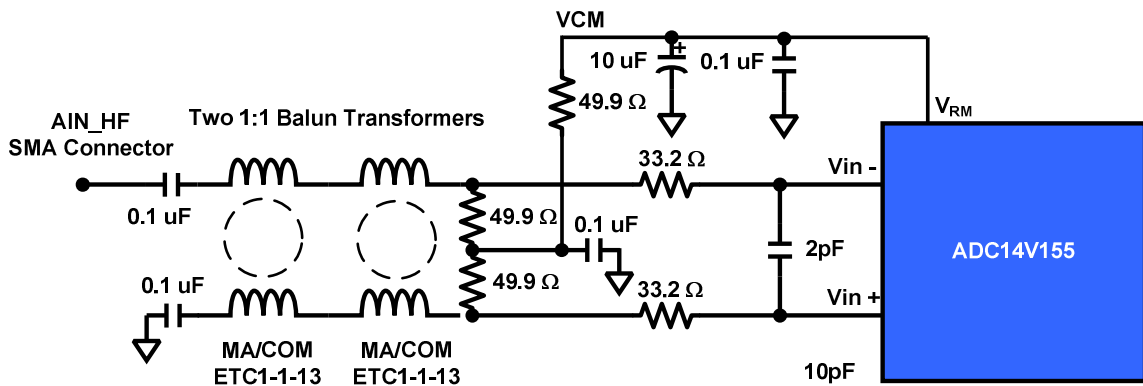

Figure 3. Analog Input Network of ADC14V155HFEB: $F_{IN} > 150$ MHz

4.3 ADC Reference and Input Common Mode

The internal 1.0V reference on the ADC14V155 is used to acquire all of the results in the ADC14V155 datasheet. It is recommended to use the internal reference on the ADC14V155. However, if an external reference is required, the ADC14V155 is capable of accepting an external reference voltage between 0.9V and 1.1V (1.0V recommended). The input impedance of the ADC14V155 V_{REF} pin (pin 46) is 9 k Ω . Therefore, to overdrive this pin, the output impedance of the external reference source should be $\ll 9$ k Ω .

It is recommended to use the voltage at the V_{RM} pin (pin 45) of the ADC14V155 to provide the 1.5V common mode voltage required for the differential analog inputs V_{IN+} and V_{IN-} . The ADC14V155 evaluation board is factory-assembled with V_{RM} connected to the transformer center-tap through a

49.9 Ω resistor to provide the necessary common mode voltage to the differential analog input.

4.4 Board Outputs

The digitized 14-bit output word from the ADC14V155 evaluation board is presented in interleaved double data rate (DDR) format. The digital output lines from the ADC14V155 evaluation board consist of 18 lines which are arranged into 9 LVDS pairs. These 9 pairs of lines carry the 14-bit output data (7 pairs), the DRDY signal which should be used to capture the output data (1 pair) and the over-range bit (OVR) which indicates that the digital output has exceeded the maximum digitizable signal (1 pair).

Since the data is presented in interleaved double data rate (DDR) format, the 14-bit word is output on 7 data pair lines with half of the data (odd bits: D1+/-, D3+/-, ..., D13+/-) being emitted with one clock edge during the first half of the clock period and the other half of the

data (even bits: D0+/-, D2+/-, ..., D12+/-) being emitted with the opposite clock edge during the second half of the clock period. The odd data bits should be captured with the falling edge of DRDY and the rising edge of DRDY should be used to capture the even bits of the data.

The data is available on the evaluation board at pins A5/B5 (MSB +/-) through A11/B11 (LSB +/-) of the FutureBus connector (schematic reference designator FB). Please keep in mind that because the data is in DDR format, pins A5/B5 will carry data bit D13+/- during the first half of the clock period and these lines will carry bit D12+/- during the second half of the clock period. Similarly, pins A11/B11 will carry D1+/- during the first half of the clock period and these pins will carry D0+/- during the second half of the clock period. The DRDY signal which is used to capture the data is also

in LVDS format and it is available at pins A4/D4 (DRDY+/-) on the FutureBus connector. The over-range bit (OVR) LVDS signal is available on pins D22/D21 (OVR+/-) on the FutureBus connector.

Please see the Evaluation Board schematic in Section 5.0 and the ADC14V155 datasheet for further details.

4.5 Power requirements.

Power to the ADC14V155 evaluation board is supplied through the green power connector labeled "+5V" which is located along the bottom edge of the board. Voltage and current requirements are:

- +5V capable of providing up to 500mA (ADC14V155 evaluation board only)

5.0 Evaluation Board Schematic

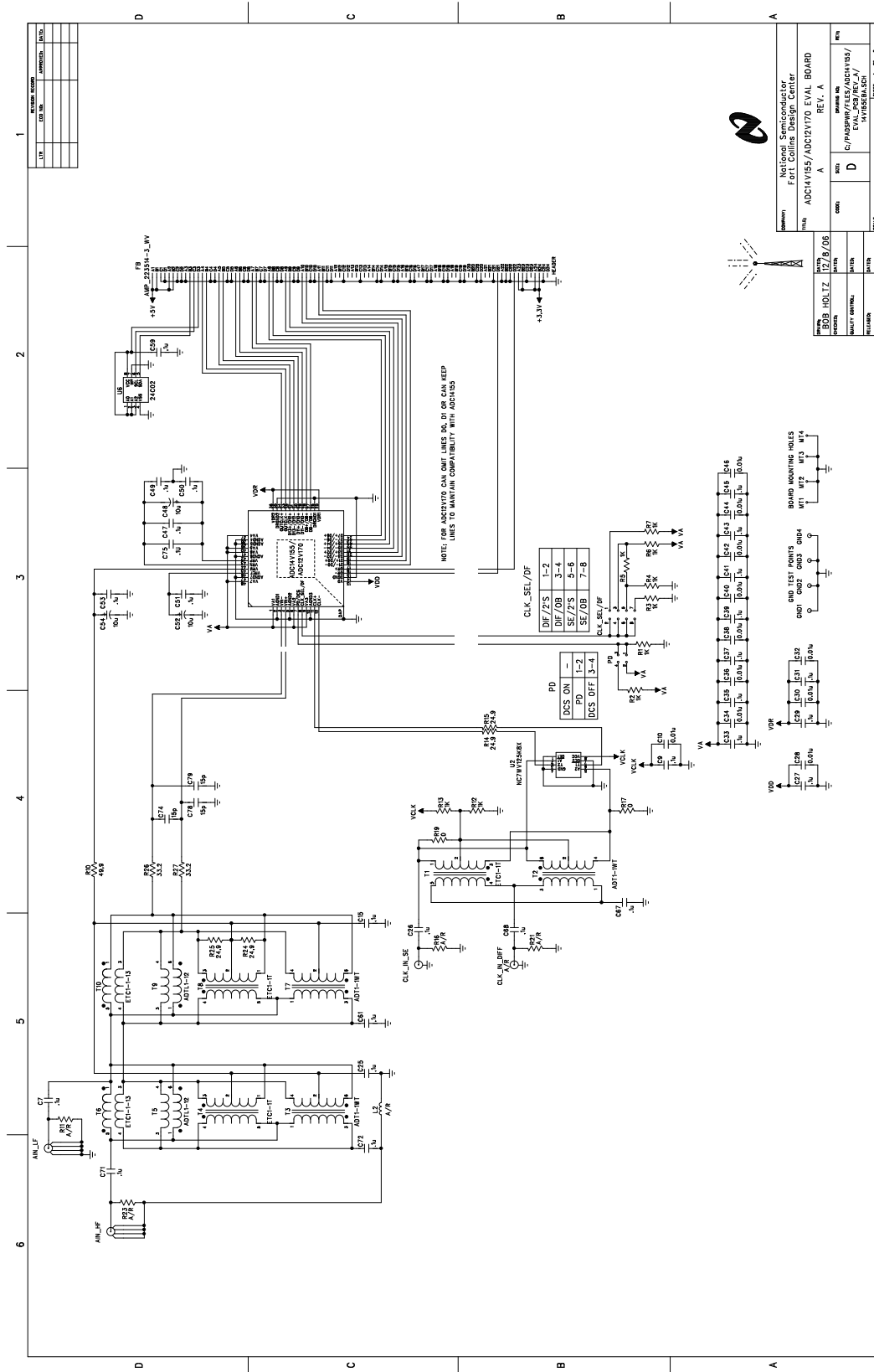

Figure 4. Signals

5.0 Schematic (cont.)

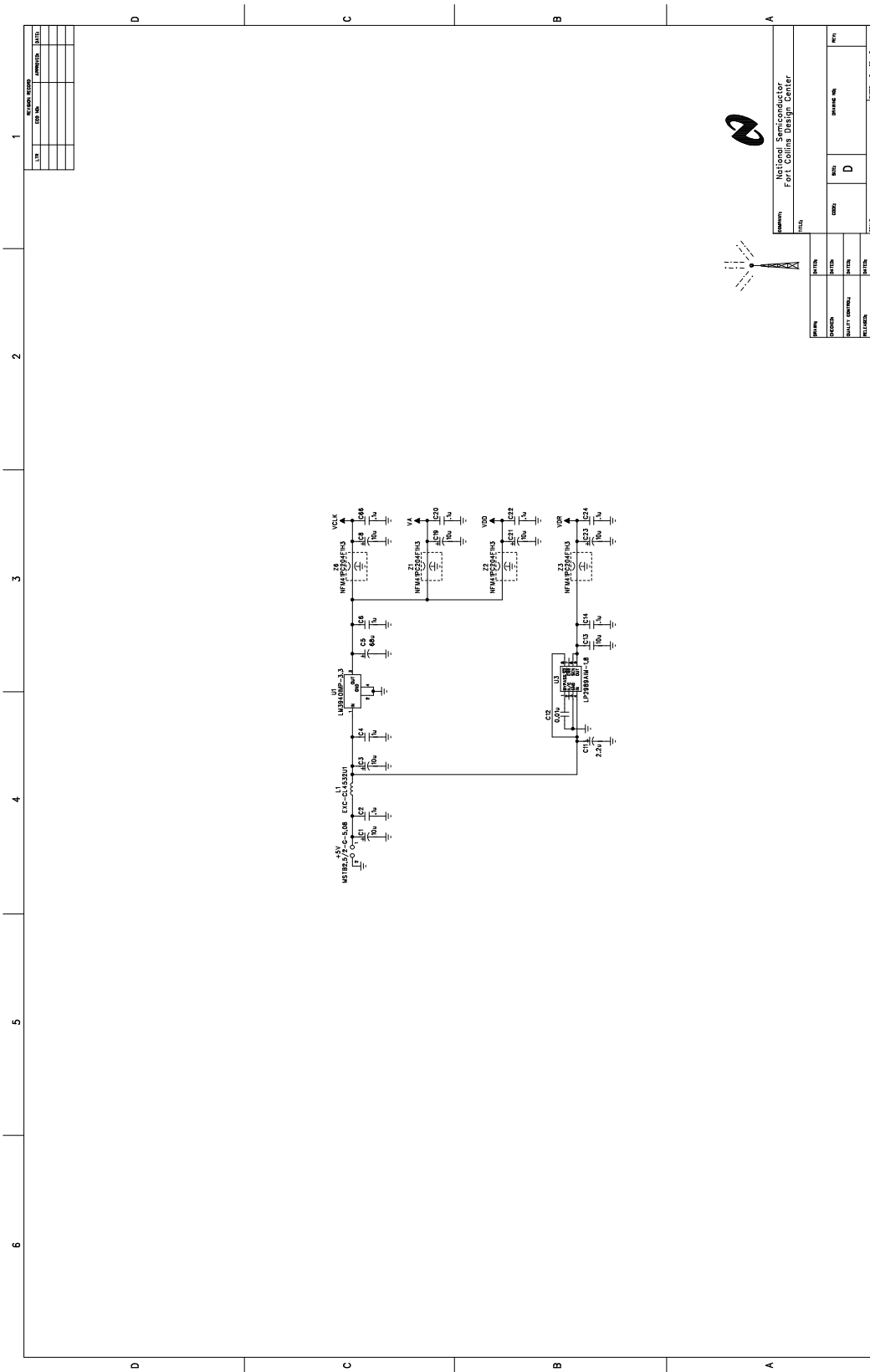

Figure 5. Power Distribution



6.0 Evaluation Board Layout

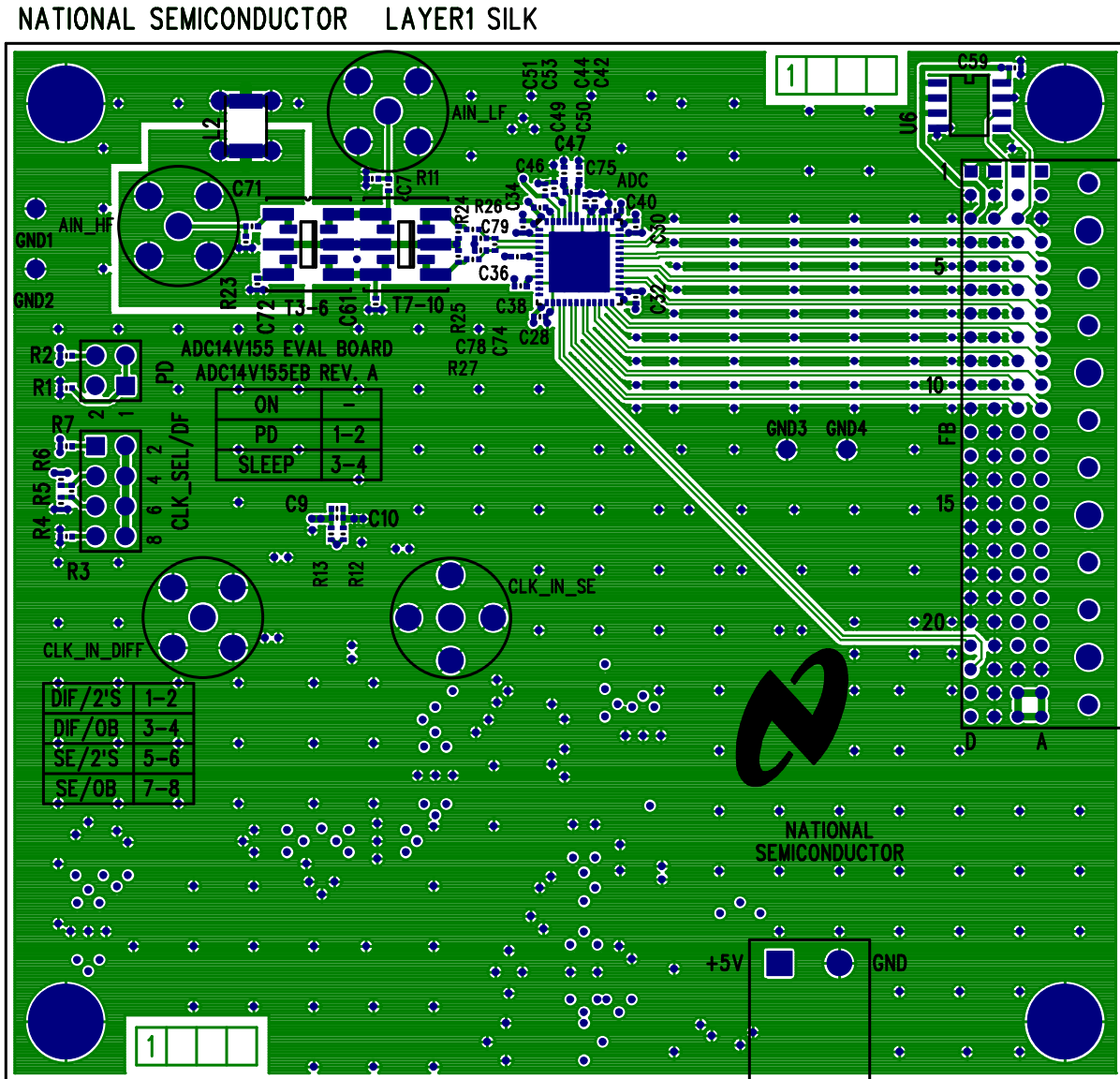

Figure 6. Layer 1 - Signal

6.0 Evaluation Board Layout (cont.)

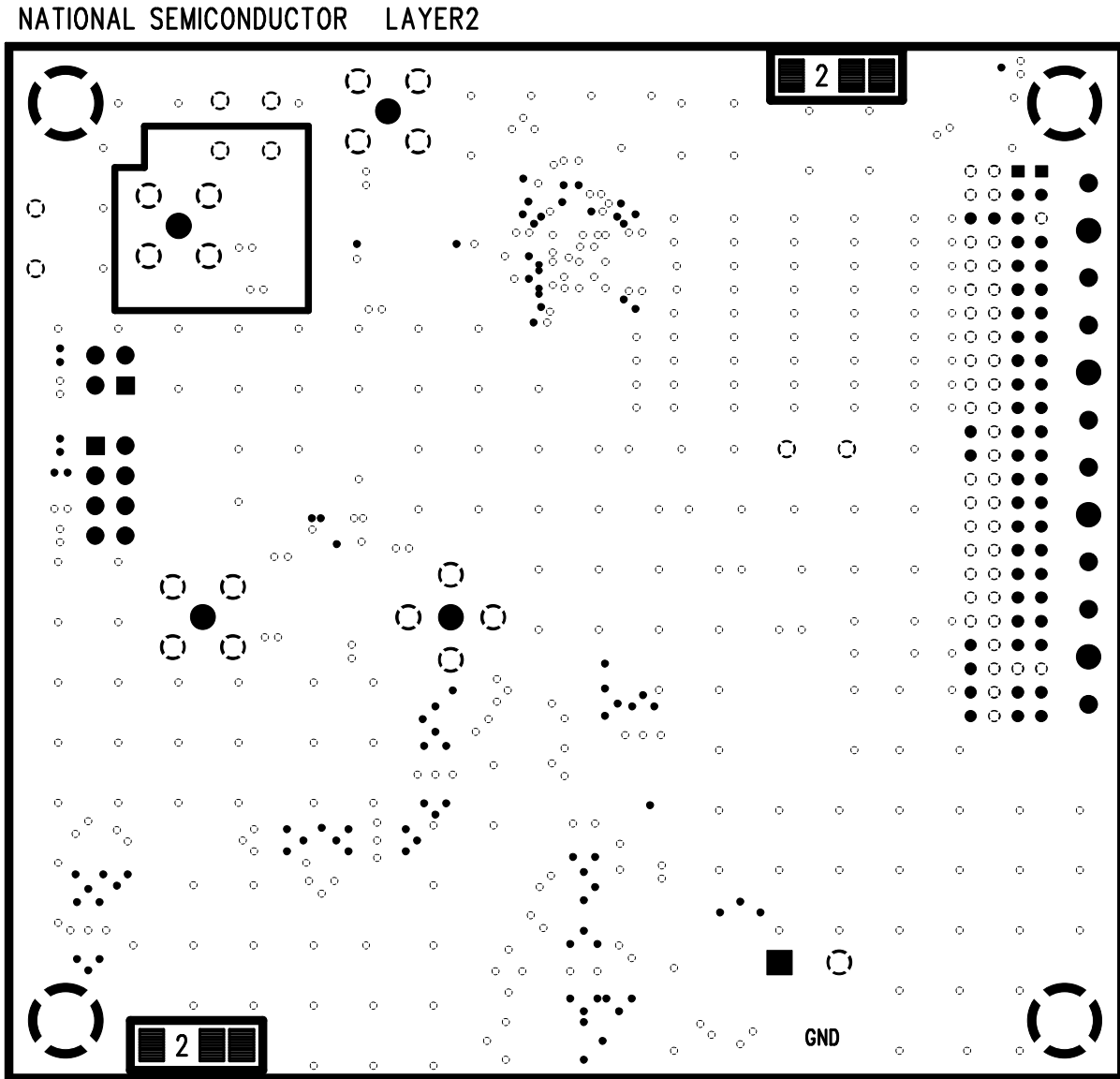

Figure 7. Layer 2 - Ground

6.0 Evaluation Board Layout (cont.)

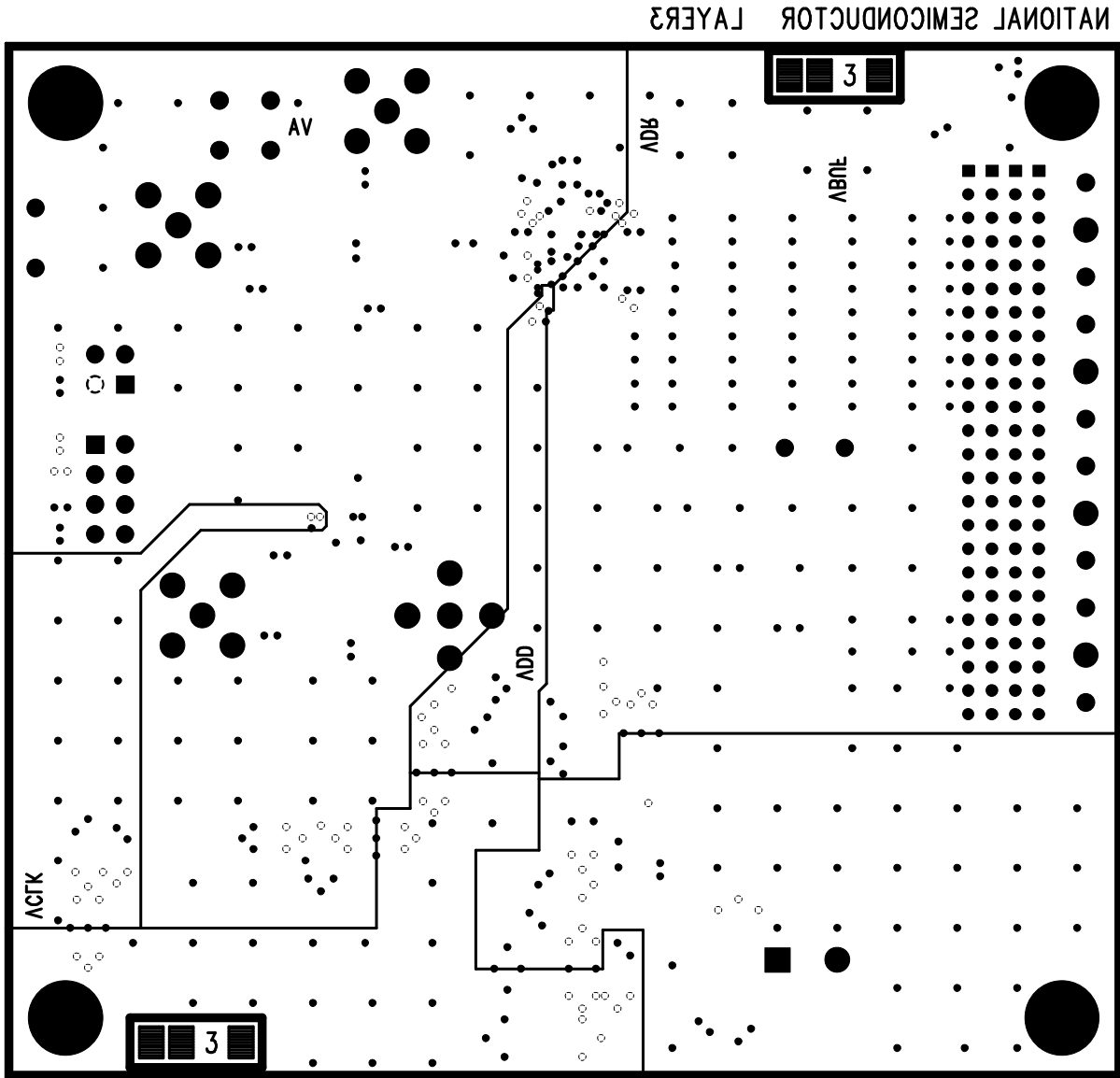

Figure 8. Layer 3 - Power

6.0 Evaluation Board Layout (cont.)

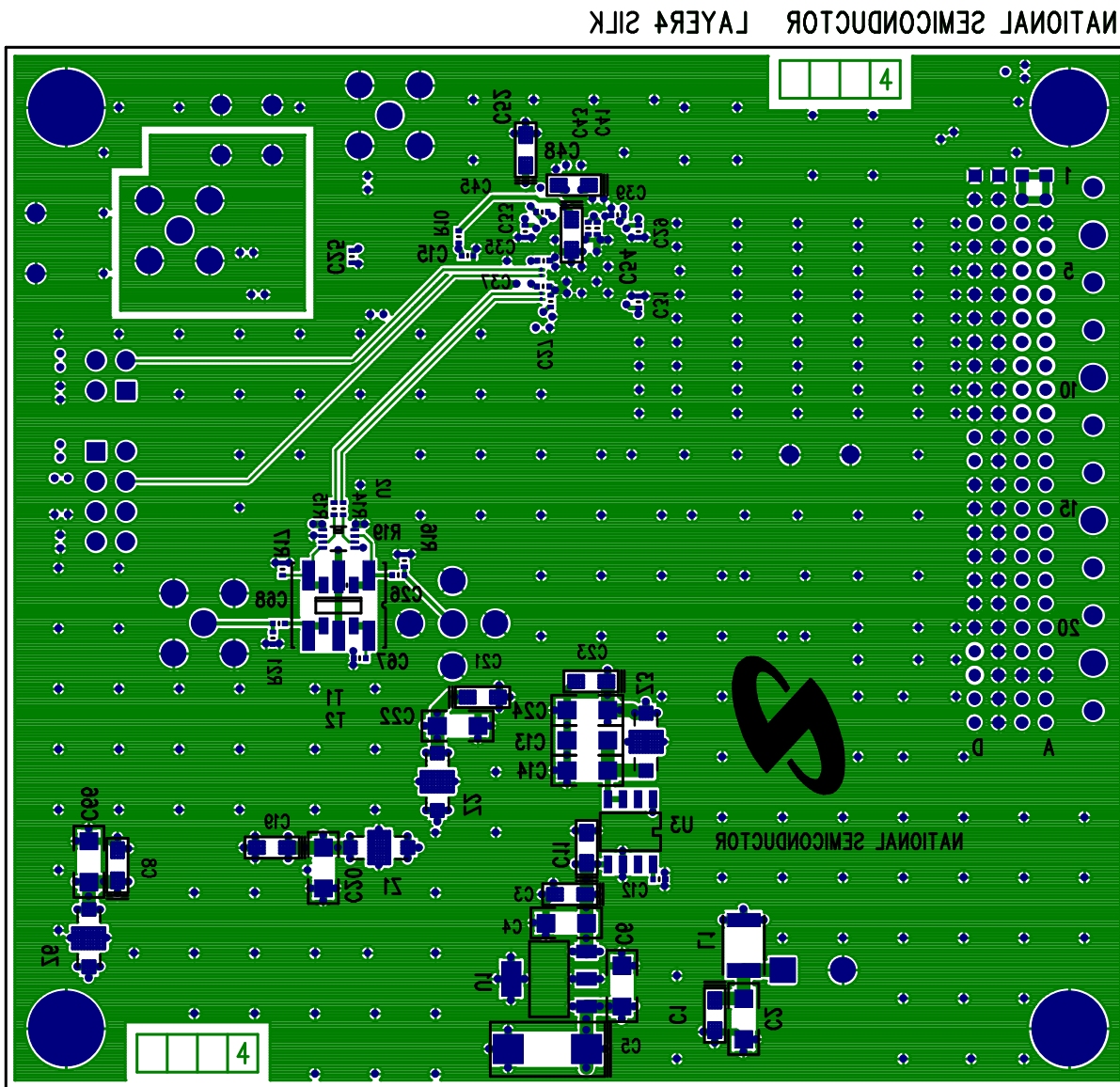

Figure 9. Layer 4 - Signal

7.0 Evaluation Board Bill of Materials

7.1 ADC14V155HFEB (For Fin > 150 MHz)

| Item | Quantity | Schematic Reference | Part Name | Description | PCB Footprint | Manufacturer |
|------|----------|---|--------------------------------|--|----------------|------------------------------------|
| 1 | 1 | U6 | 24C02 | 2K SERIAL EEPROM 1.8V | SOIC-8 | Atmel |
| 2 | 1 | ADC | ADC14V155 | 14-Bit, 155 MSPS Analog/Digital Converter with LVDS Outputs | 48-LLP | National Semiconductor |
| 3 | 2 | T6, T10 | ETC1-1-13 | BALUN TRANSFORMER | | MA/COM |
| 4 | 4 | FB | AMP 5223514-1 | Z-PACK 2mm FB (Futurebus+) RIGHT ANGLE HEADER CONNECTOR | - | AMP |
| 5 | 1 | C75 | 0.1uF | 0.1uF SMD CAP CERAMIC 6.3V X5R 10% | sm/c_0201 | Panasonic - ECG |
| 6 | 6 | C2, C14, C20, C22, C24, C66 | 0.1uF | 0.1uF SMD CAP CERAMIC 25V X7R 10% | sm/c_1206 | Panasonic - ECG |
| 7 | 21 | C9, C15, C26, C27, C29, C31, C33, C35, C37, C39, C41, C43, C45, C47, C49-51, C53, C59, C71, C72 | 0.1uF | 0.1uF SMD CAP CERAMIC 10V X5R 10% | sm/c_0402 | Panasonic - ECG |
| 8 | 12 | C10, C12, C28, C30, C32, C34, C36, C38, C40, C42, C44, C46 | 0.01uF | 0.01uF SMD CAP CERAMIC 16V X7R 10% | sm/c_0402 | AVX Corporation |
| 9 | 1 | C13 | 10uF | 10uF SMD CAP CERAMIC 10V X5R 20% | sm/c_1206 | Panasonic - ECG |
| 10 | 1 | C74 | 2pF | 2pF SMD CAP CERAMIC 50v +/-0.25pF | sm/c_0402 | Murata Electronics |
| 11 | 2 | C4, C6 | 1uF | 1uF SMD CAP CERAMIC 25V X7R 10% | sm/c_1206 | Panasonic - ECG |
| 12 | 9 | C1, C3, C8, C19, C21, C23, C48, C52, C54 | 10uF | 10uF SMD CAP TANTALUM 6.3V 20% | sm/c_3216 | Kemet |
| 13 | 1 | C11 | 2.2uF | 2.2uF SMD CAP TANTALUM 16V 10% | sm/c_3216 | Kemet |
| 14 | 1 | C5 | 68uF | 68uF SMD CAP TANTALUM 6.3V 10% | sm/c_7343 | Kemet |
| 15 | 2 | L1, L2 | Ferrite Bead Core | SMD FERRITE BEAD CORE 4.5X3.2X1.8 | - | Panasonic - ECG |
| 16 | 1 | JTAG | Jumper 1x8 | JUMPER BLOCK USING 8 PIN SIP HEADER | - | Samtec |
| 17 | 1 | PD | Jumper 2X2 | 2X2 JUMPER BLOCK HEADER CUT TO SIZE FROM 2X6 HEADER | - | Samtec |
| 18 | 1 | CLK_SEL/DF | Jumper 2X4 | 2X4 JUMPER BLOCK HEADER CUT TO SIZE FROM 2X6 HEADER | - | Samtec |
| 19 | 1 | - | Shunt | PLACE SHUNT ACROSS PINS 7-8 ON CLK_SEL/DF JUMPER | - | FCI Electronic |
| 20 | 1 | U1 | 3.3V Regulator | 1A LOW DROPOUT REGULATOR FOR 5V TO 3.3 V CONVERSION | SOT-223 | National Semiconductor |
| 21 | 1 | U3 | 1.8V Regulator | MICROPOWER/LOW NOISE, 500 mA ULTRA LOW-DROPOUT REGULATO | SOIC NARROW -8 | National Semiconductor |
| 22 | 1 | +5V | Power Connector Terminal Block | TERMINAL BLOCK 2POS 5.08mm | - | Phoenix Contact |
| 23 | 1 | - | Power Connector Plug | TERMINAL BLOCK PLUG 2POS 5.08mm | - | Phoenix Contact |
| 24 | 4 | MT1-4 | Bump-on Rubber Feet | PLACE BUMP ONS AT THE 4 CORNERS, ON BOTTOM OF BOARD | - | 3M |
| 25 | 1 | U2 | Tinylogic Buffer | TINYLOGIC ULP-A BUFFER WITH 3-STATE OUTPUT 8-LEAD US8, JEDEC MO-187, CA 3.1 mm WIDE | - | Fairchild Semiconductor |
| 26 | 4 | Z1-3, Z6 | Noise Suppression Filter | FILTER LC HIGH FREQ .2UF | 1806 | Murata Electronics |
| 27 | 2 | R17, R19 | 0 ohms | 0 OHM SMD RESISTOR | sm/r_0402 | Vishay Dale |
| 28 | 9 | R1-7, R12-13 | 1 KOHM | 1 KOHM SMD RESISTOR 1/16W 1% | sm/r_0402 | Panasonic - ECG |
| 29 | 2 | R14-15 | 24.9 ohms | 24.9 OHM SMD RESISTOR 1/16W 1% | sm/r_0402 | Yageo Corporation |
| 30 | 2 | R26-27 | 33.2 ohms | 33.2 OHM SMD RESISTOR 1/16W 1% | sm/r_0402 | Vishay Dale |
| 31 | 3 | R10, R24-25 | 49.9 ohms | 49.9 OHM SMD RESISTOR 1/16W 1% | sm/r_0402 | Yageo Corporation |
| 32 | 2 | AIN_HF, CLK_IN_SE | SMA Input | PCB MOUNTABLE SMA CONNECTOR | - | Emerson Network Power Connectivity |

7.0 Evaluation Board Bill of Materials (cont.)

7.2 ADC14V155LFE8 (For Fin < 150 MHz)

| Item | Quantity | Schematic Reference | Part Name | Description | PCB Footprint | Manufacturer |
|------|----------|---|--------------------------------|--|----------------|------------------------------------|
| 1 | 1 | U6 | 24C02 | 2K SERIAL EEPROM 1.8V | SOIC-8 | Atmel |
| 2 | 1 | ADC | ADC14V155 | 14-Bit, 155 MSPS Analog/Digital Converter with LVDS Outputs | 48-LLP | National Semiconductor |
| 3 | 1 | T7 | ADT1-1WT+ | WIDEBAND RF TRANSFORMER 0.4MHz - 800 MHz | CD542 | MINI CIRCUITS |
| 4 | 4 | FB | AMP_5223514-1 | Z-PACK 2mm FB (Futurebus+) RIGHT ANGLE HEADER CONNECTOR | - | AMP |
| 5 | 1 | C75 | 0.1uF | 0.1uF SMD CAP CERAMIC 6.3V X5R 10% | sm/c_0201 | Panasonic - ECG |
| 6 | 6 | C2, C14, C20, C22, C24, C66 | 0.1uF | 0.1uF SMD CAP CERAMIC 25V X7R 10% | sm/c_1206 | Panasonic - ECG |
| 7 | 21 | C9, C15, C26, C27, C29, C31, C33, C35, C37, C39, C41, C43, C45, C47, C49-51, C53, C59, C71, C72 | 0.1uF | 0.1uF SMD CAP CERAMIC 10V X5R 10% | sm/c_0402 | Panasonic - ECG |
| 8 | 12 | C10, C12, C28, C30, C32, C34, C36, C38, C40, C42, C44, C46 | 0.01uF | 0.01uF SMD CAP CERAMIC 16V X7R 10% | sm/c_0402 | AVX Corporation |
| 9 | 1 | C13 | 10uF | 10uF SMD CAP CERAMIC 10V X5R 20% | sm/c_1206 | Panasonic - ECG |
| 10 | 3 | C74, C78-79 | 15pF | 15pF SMD CAP CERAMIC 50v NP0 5% | sm/c_0402 | Panasonic - ECG |
| 11 | 2 | C4, C6 | 1uF | 1uF SMD CAP CERAMIC 25V X7R 10% | sm/c_1206 | Panasonic - ECG |
| 12 | 9 | C1, C3, C8, C19, C21, C23, C48, C52, C54 | 10uF | 10uF SMD CAP TANTALUM 6.3V 20% | sm/c_3216 | Kemet |
| 13 | 1 | C11 | 2.2uF | 2.2uF SMD CAP TANTALUM 16V 10% | sm/c_3216 | Kemet |
| 14 | 1 | C5 | 68uF | 68uF SMD CAP TANTALUM 6.3V 10% | sm/c_7343 | Kemet |
| 15 | 2 | L1, L2 | Ferrite Bead Core | SMD FERRITE BEAD CORE 4.5X3.2X1.8 | - | Panasonic - ECG |
| 16 | 1 | JTAG | Jumper 1x8 | JUMPER BLOCK USING 8 PIN SIP HEADER | - | Samtec |
| 17 | 1 | PD | Jumper 2X2 | 2X2 JUMPER BLOCK HEADER CUT TO SIZE FROM 2X6 HEADER | - | Samtec |
| 18 | 1 | CLK_SEL/DF | Jumper 2X4 | 2X4 JUMPER BLOCK HEADER CUT TO SIZE FROM 2X6 HEADER | - | Samtec |
| 19 | 1 | - | Shunt | PLACE SHUNT ACROSS PINS 7-8 ON CLK_SEL/DF JUMPER | - | FCI Electronic |
| 20 | 1 | U1 | 3.3V Regulator | 1A LOW DROPOUT REGULATOR FOR 5V TO 3.3 V CONVERSION | SOT-223 | National Semiconductor |
| 21 | 1 | U3 | 1.8V Regulator | MICROPOWER/LOW NOISE, 500 mA ULTRA LOW-DROPOUT REGULATI | SOIC NARROW -8 | National Semiconductor |
| 22 | 1 | +5V | Power Connector Terminal Block | TERMINAL BLOCK 2POS 5.08mm | - | Phoenix Contact |
| 23 | 1 | - | Power Connector Plug | TERMINAL BLOCK PLUG 2POS 5.08mm | - | Phoenix Contact |
| 24 | 4 | MT1-4 | Bump-on Rubber Feet | PLACE BUMP ONS AT THE 4 CORNERS, ON BOTTOM OF BOARD | - | 3M |
| 25 | 1 | U2 | Tinylogic Buffer | TINYLOGIC ULP-A BUFFER WITH 3-STATE OUTPUT 8-LEAD US8, JEDEC MO-187, CA 3.1 mm WIDE | - | Fairchild Semiconductor |
| 26 | 4 | Z1-3, Z6 | Noise Suppression Filter | FILTER LC HIGH FREQ .2UF | 1806 | Murata Electronics |
| 27 | 2 | R17, R19 | 0 ohms | 0 OHM SMD RESISTOR | sm/r_0402 | Vishay Dale |
| 28 | 9 | R1-7, R12-13 | 1 KOHM | 1 KOHM SMD RESISTOR 1/16W 1% | sm/r_0402 | Panasonic - ECG |
| 29 | 4 | R14-15, R24-25 | 24.9 ohms | 24.9 OHM SMD RESISTOR 1/16W 1% | sm/r_0402 | Yageo Corporation |
| 30 | 2 | R26-27 | 33.2 ohms | 33.2 OHM SMD RESISTOR 1/16W 1% | sm/r_0402 | Vishay Dale |
| 31 | 1 | R10 | 49.9 ohms | 49.9 OHM SMD RESISTOR 1/16W 1% | sm/r_0402 | Yageo Corporation |
| 32 | 2 | AIN_LF, CLK_IN_SE | SMA Input | PCB MOUNTABLE SMA CONNECTOR | - | Emerson Network Power Connectivity |

The ADC14V155 Evaluation Board is intended for product evaluation purposes only and is not intended for resale to end consumers, is not authorized for such use and is not designed for compliance with European EMC Directive 89/336/EEC.

WaveVision is a trademark of National Semiconductor Corporation. National does not assume any responsibility for use of any circuitry or software supplied or described. No circuit patent licenses are implied.

LIFE SUPPORT POLICY

NATIONAL'S PRODUCTS ARE NOT AUTHORIZED FOR USE AS CRITICAL COMPONENTS IN LIFE SUPPORT DEVICES OR SYSTEMS WITHOUT THE EXPRESS WRITTEN APPROVAL OF THE PRESIDENT OF NATIONAL SEMICONDUCTOR CORPORATION. As used herein:

1. Life support devices or systems are devices or systems which, (a) are intended for surgical implant into the body, or (b) support or sustain life, and whose failure to perform, when properly used in accordance with instructions for use provided in the labeling, can be reasonably expected to result in a significant injury to the user.
2. A critical component is any component in a life support device or system whose failure to perform can be reasonably expected to cause the failure of the life support device or system, or to affect its safety or effectiveness.

| | | | | |
|---|--|--|--|--|
|  | National Semiconductor Corporation Americas Tel: 1-800-272-9959 Fax: 1-800-737-7018 Email: support@nsc.com | National Semiconductor Europe Fax: +49 (0) 1 80-530 85 86 Email: europe.support@nsc.com Deutsch Tel: +49 (0) 1 80-530 85 85 English Tel: +49 (0) 1 80 532 78 32 | National Semiconductor Asia Pacific Customer Response Group Tel: 65-2544466 Fax: 65-2504466 Email: sea.support@nsc.com | National Semiconductor Japan Ltd. Tel: 81-3-5639-7560 Fax: 81-3-5639-7507 |
|---|--|--|--|--|

National does not assume any responsibility for any circuitry described, no circuit patent licenses are implied and National reserves the right at any time without notice to change said circuitry and specifications.