

Evaluation Board User's Guide

ADC10DV200, 10-Bit, 200 Msp/s A/D Converter

ADC11DV200, 11-Bit, 200 Msp/s A/D Converter

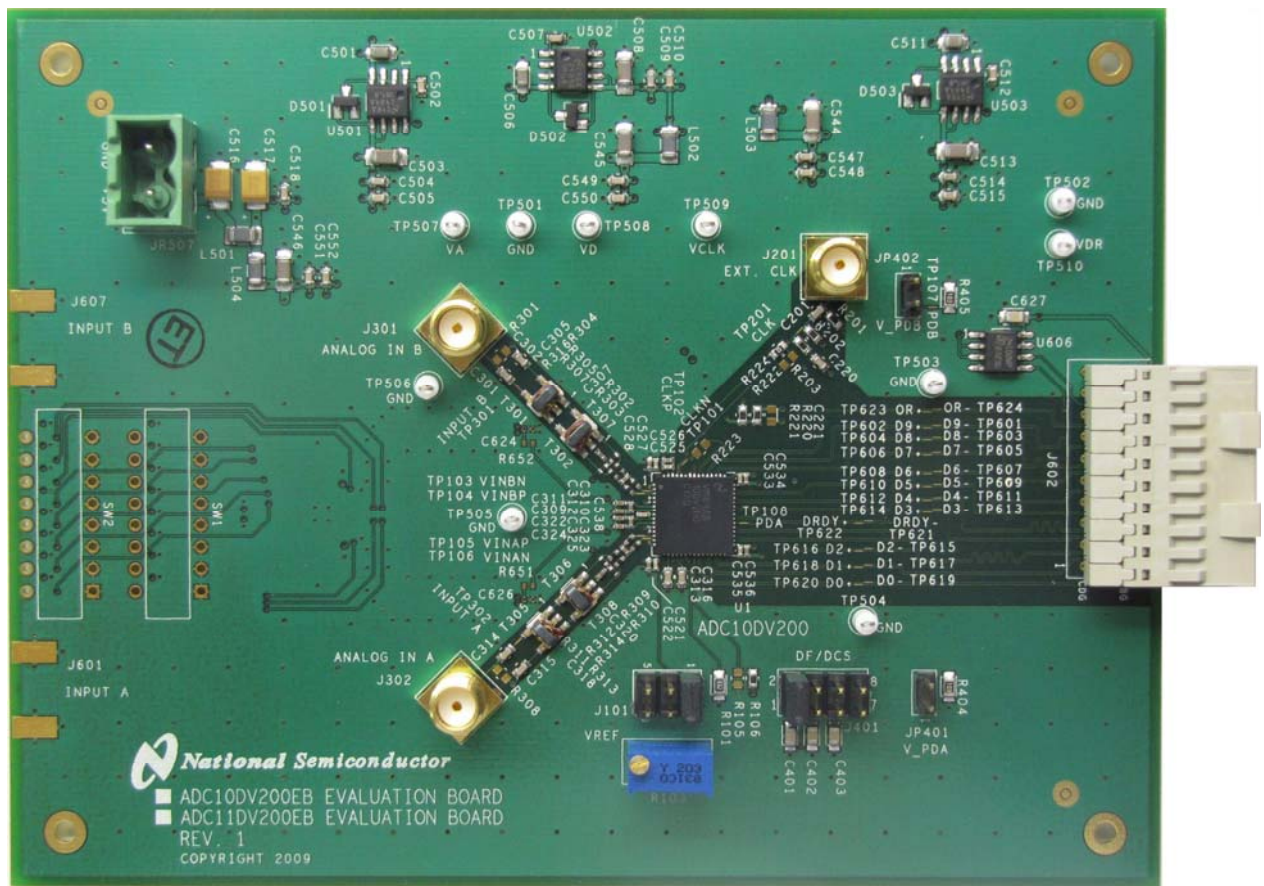

Table of Contents

1.0 Introduction	3
2.0 Board Assembly	3
3.0 Quick Start.....	4
4.0 Functional Description	4
4.1 Analog Input	4
4.2 ADC reference circuitry	5
4.3 ADC clock circuit	5
4.4 Digital Data Output	5
4.5 Data Format/ Duty Cycle Stabilizer	5
4.6 Power Supply Connections	5
5.0 Installing the ADC10DV200 Evaluation Board.....	5
6.0 Hardware Schematic.....	6
7.0 Evaluation Board Layout.....	12
8.0 Evaluation Board Bill of Materials.....	15
A1.0 Operating in the Computer Mode	17
A2.0 Summary Tables of Test Points, Connectors, and Jumper Settings.....	17
A2.1 Test Points	17
A2.2 Connectors.....	17
A2.3 Jumper settings	17
A2.4 Clock Circuit Solder Jumper settings	18

1.0 Introduction

This Evaluation Board may be used to evaluate the ADC10DV200, or ADC11DV200. The ADC is one of a family of 10 and 11 bit converters that provides data at rates of up to 200MHz. Further reference in this manual to the ADC10DV200 is meant to also include the other listed parts unless otherwise specified

The evaluation board is designed to be used with the WaveVision5™ Data Capture Board which is connected to a personal computer through a USB port and running WaveVision5™ software, operating under Microsoft Windows. The software can perform an FFT on the captured data upon command and, in addition to a

frequency domain plot, shows dynamic performance in the form of SNR, SINAD, THD and SFDR. The latest WaveVision hardware and software is available through the National Semiconductor website:

http://www.national.com/store/view_item/index.html?nsid=WAVEVSN+BRD+5.1

2.0 Board Assembly

The ADC10DV200 Evaluation Board comes pre-assembled. Refer to the Bill of Materials in Section 8 for a description of components, to Figure 1 for major component placement and to Section 6 for the Evaluation Board schematic.

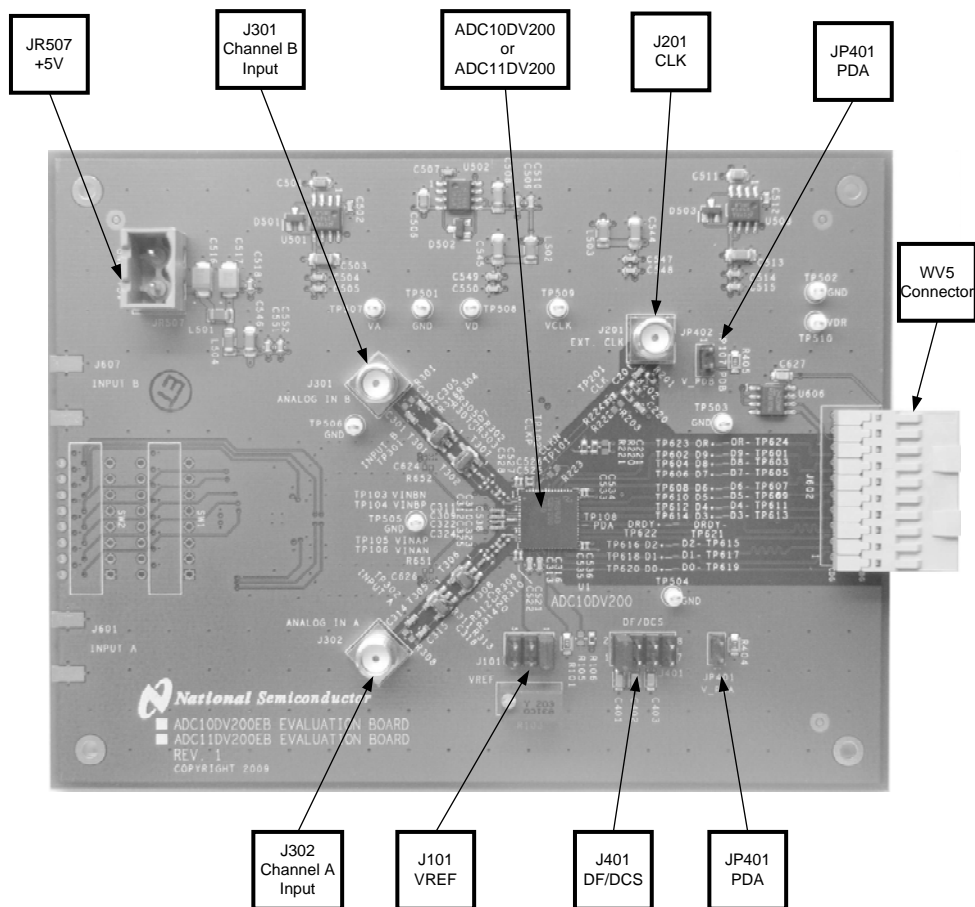

Figure 1. Major Component and Jumper Locations

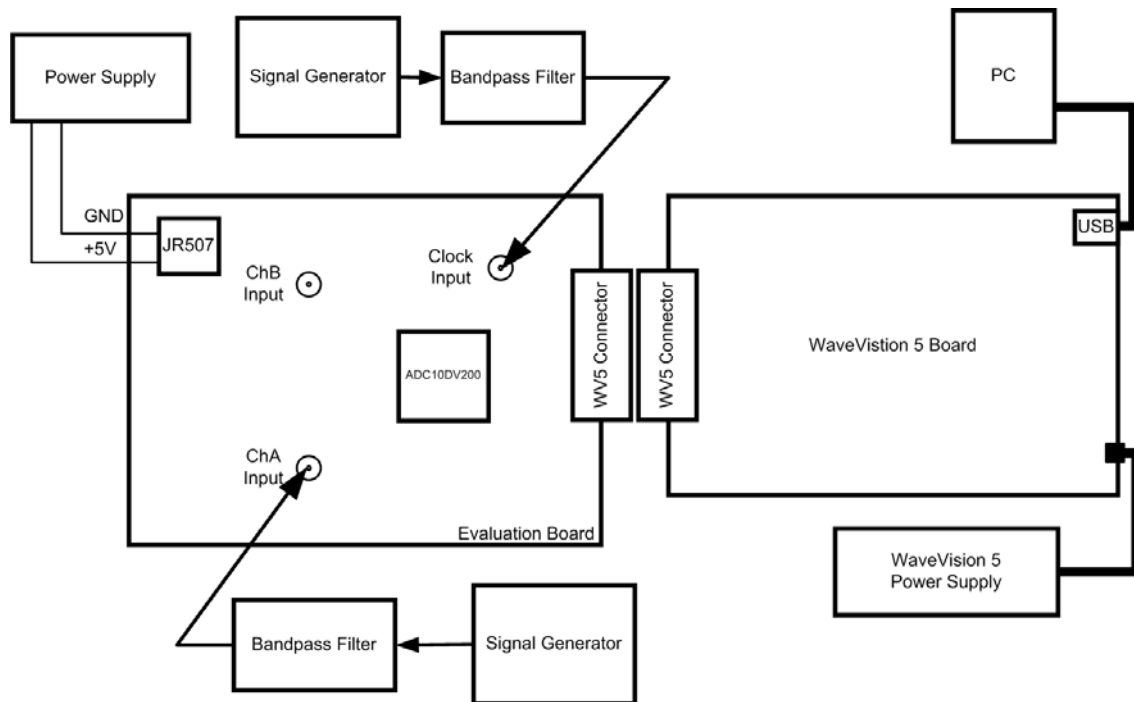

Figure 2. Test Set up

3.0 Quick Start

Refer to *Figure 1* for locations of jumpers, test points and major components. Refer to *Figure 2* for the test set up. The board is configured by default to use a external clock source and internal reference. Refer to Section 4.0 and the Appendix for more information on jumper settings. The input network of this board is configured for input frequencies greater than 70MHz. Refer to Section 4.1 for more information about input networks.

You must have version 5.0 or later of the WaveVision™ software to properly test this board. You can download the latest version from:

<http://www.national.com/analog/adc/wavevision5>

1. Apply power to the WaveVision5™ board and connect it to the computer using a USB cable. See the WaveVision5™ Board Manual for operation of that board. Connect the evaluation board to the WaveVision™ Digital Interface Board.
2. Connect a clean +5V power supply to pin 2 of Power Connector JR507. Pin 1 is ground.
3. Connect a signal from a 50-Ohm source to connector J301 or J302. Be sure to use a bandpass filter before the Evaluation Board.
4. Adjust the input signal amplitude as needed to ensure that the signal does not over-range by examining a histogram of the output data with the WaveVision5™ software.

4.0 Functional Description

The ADC10DV200 Evaluation Board schematic is shown in *Section 6*. A list of test points and jumper settings can be found in the Appendix.

4.1 Analog Input

To obtain the best distortion results the analog input network must be optimized for the signal frequency being applied. The ADC10DV200 Evaluation Board comes configured as seen in *Figure 3*.

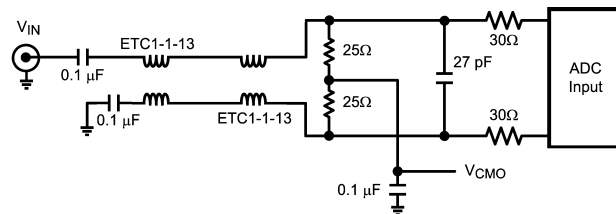

Figure 3. Analog Input Network for $F_{IN} > 70\text{MHz}$

The input network is intended to accept a low-noise sine wave and will perform well over a wide input frequency range. To accurately evaluate the dynamic performance of this converter, the input test signal will have to be passed through a high-quality bandpass filter.

Input signals can also be amplified using an onboard LMH6517 DVGA (U601). To use the DVGA, some components must be installed and some removed. The following components must be installed: R651-R656. The following components must be removed: R302, R303, R309, and R310. Then connect signals from a 50-Ohm source to connectors J601 and J607.

4.2 ADC reference circuitry

The ADC10DV200 can use an internal or external voltage reference. The internal reference is selectable between a 0.75V or 0.5V reference. External references can be set from 0.2V to 1.4V. This Evaluation Board is configured to use the internal 0.75V reference.

4.3 ADC clock circuit

Components can be installed or removed to select the path of the clock to the ADC. While not as convenient as pin-type jumpers, these introduce less distortion into the clock signal.

Care must be taken to provide a high quality low jitter clock source. A single ended input clock can be buffered by U203 (NC7SV125) and applied to the ADC's clock input pin. Or U203 can be bypassed and the input clock pin driven directly.

A differential clock can also be applied to the ADC's clock input pins through U201 (ETC-1-13).

Refer to Appendix A to configure the clock for your application. The Evaluation Board is configured by default to use a single ended clock to drive the input pins directly.

4.4 Digital Data Output

The LVDS digital output data is available for probing at test points TP601 through TP624. The signals are also available at the WaveVision™ (WV5) connector J602.

4.5 Data Format/ Duty Cycle Stabilizer

Output data format and the duty cycle stabilizer (DCS) are controlled by jumper J401.

Shorting pins 1-2 of J401 sets the output format to offset binary with DCS On. This is the default setting.

Shorting pins 3-4 of J401 sets the output format to 2's complement with DCS Off.

Shorting pins 5-6 of J401 sets the output format to offset binary with DCS Off.

Shorting pins 7-8 of J401 sets the output format to 2's complement with DCS On.

4.6 Power Supply Connections

Power to this board is supplied through power connector J507. The only supply needed is +5V at pin 2 plus ground at pin 1.

Voltage and current requirements for the ADC10DV200 Evaluation Board are:

- +5.0V at 500 mA

5.0 Installing the ADC10DV200 Evaluation Board

The evaluation board requires power supplies as described in *Section 4.6*. An appropriate signal source

should be connected to the Signal Input SMA connectors J301 or J302. When evaluating dynamic performance, an appropriate signal generator (such as the HP8644B or the R&S SME-03) with 50 Ohm source impedance should be connected to the Analog Input connector through an appropriate bandpass filter as even the best signal generator available can not produce a signal pure enough to evaluate the dynamic performance of an ADC.

If this board is used in conjunction with the WaveVision5™ Data Capture Board and WaveVision5™ software, a USB must be connected between the Data Capture Board and the host. See the WaveVision5™ Data Capture Board manual for details.

6.0 Hardware Schematic

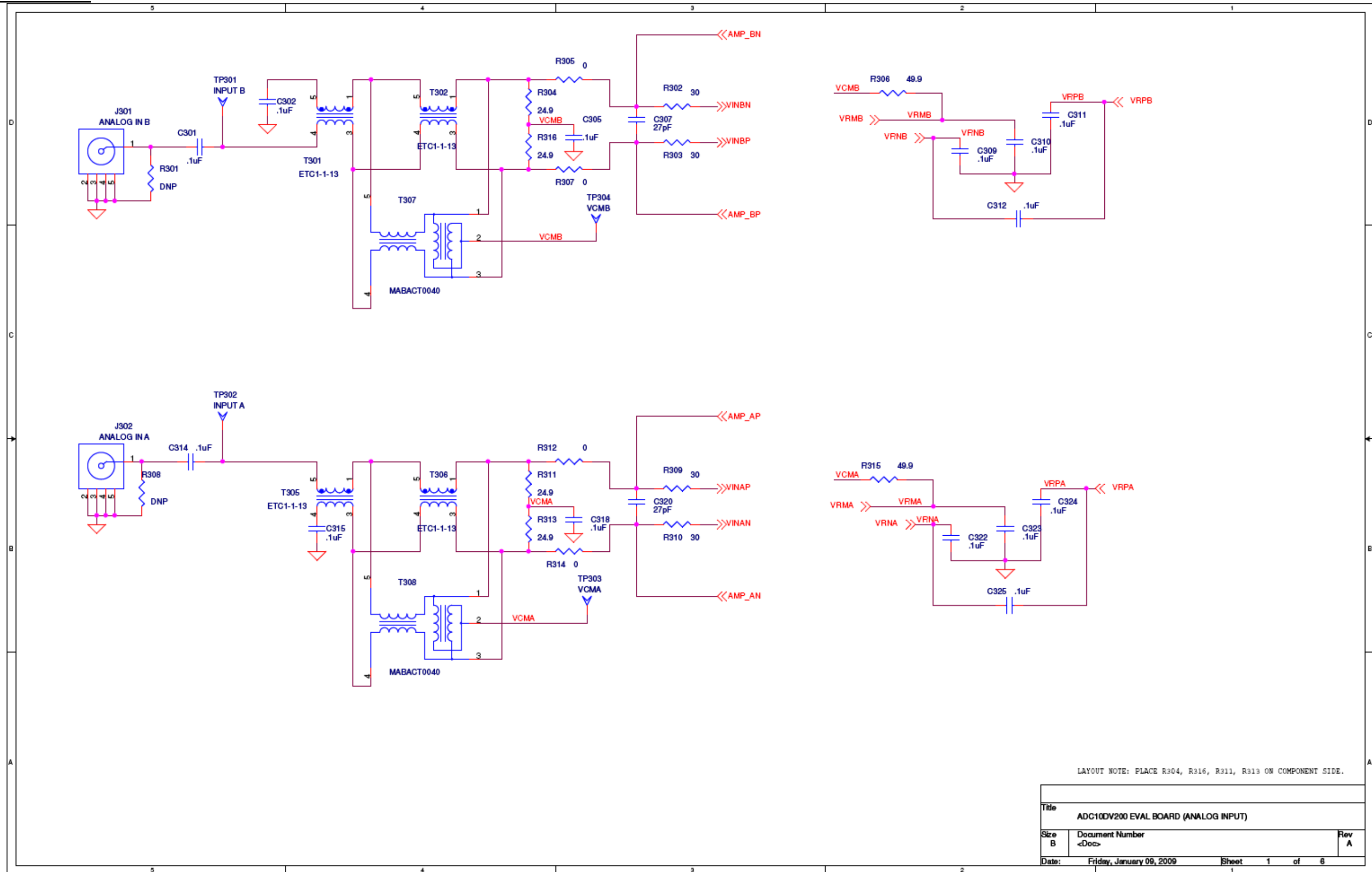

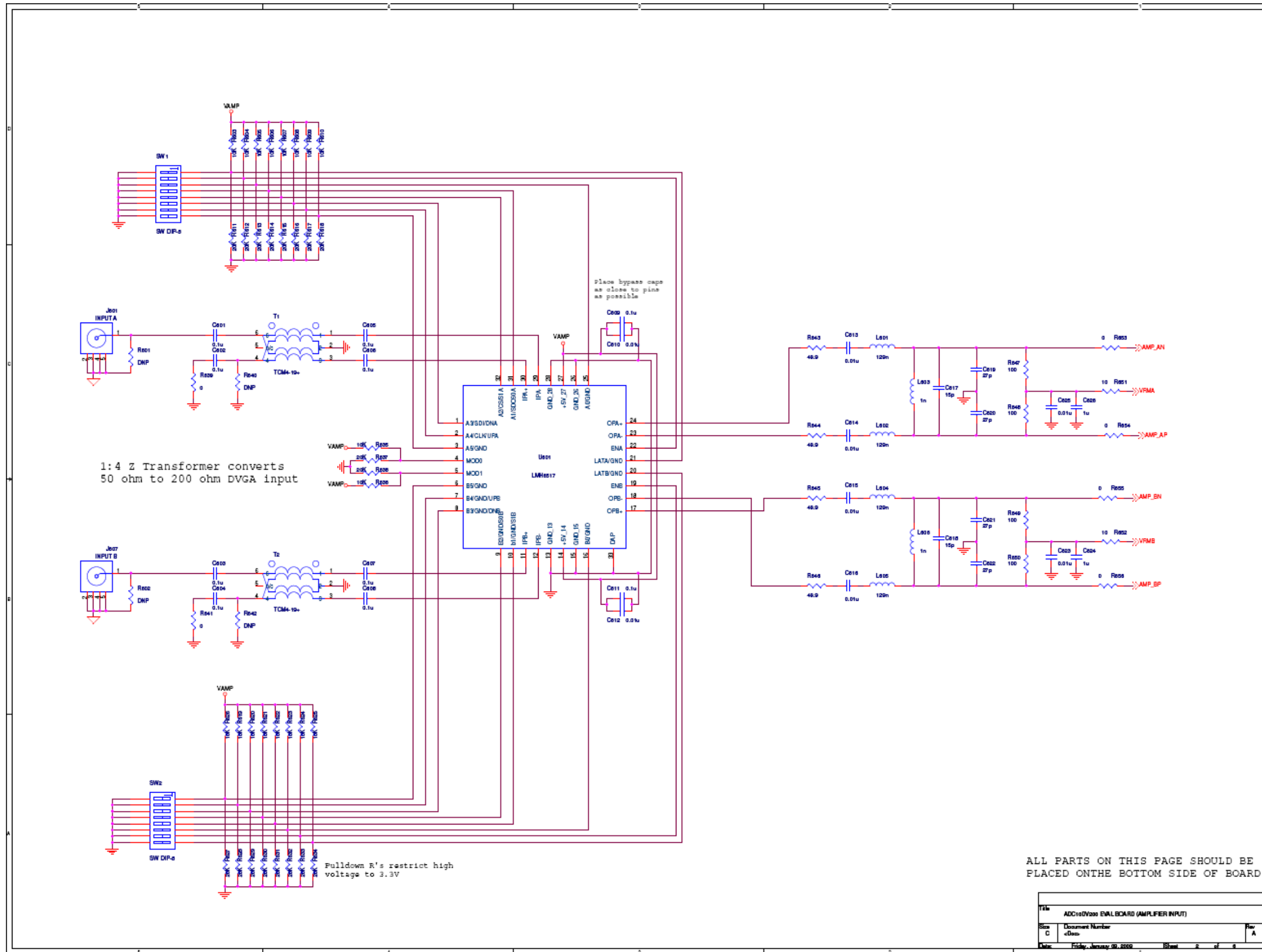

ALL PARTS ON THIS PAGE SHOULD BE PLACED ON THE BOTTOM SIDE OF BOARD

File	ADC16D500 EVALBOARD (AMPLIFIER INPUT)	
Size	Document Number	Rev
C	<Doc>	A
Date	Friday, January 29, 2009	Sheet 2 of 8

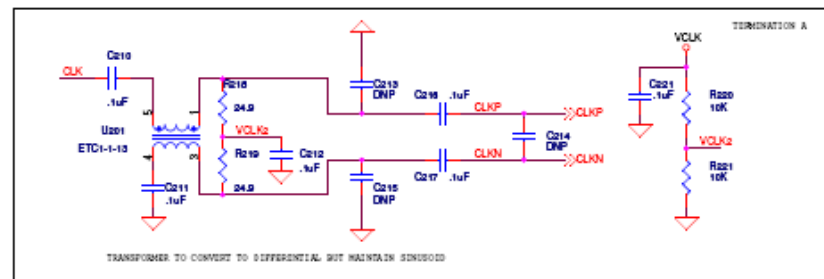
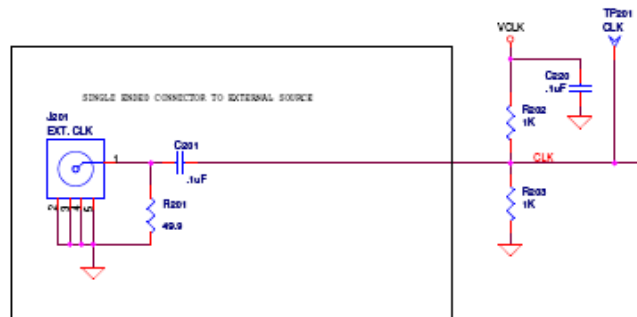

TRANSFORMER TO CONVERT TO DIFFERENTIAL BUT MAINTAIN SINUSOID

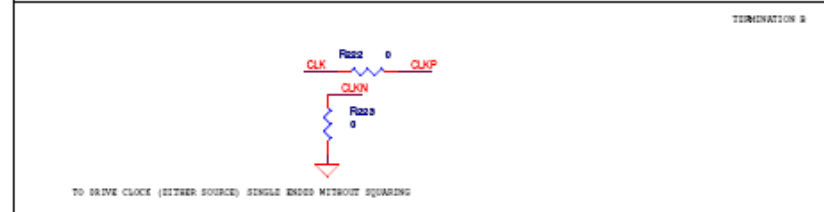

TO DRIVE CLOCK (EITHER SOURCE) SINGLE ENDED WITHOUT SQUARING

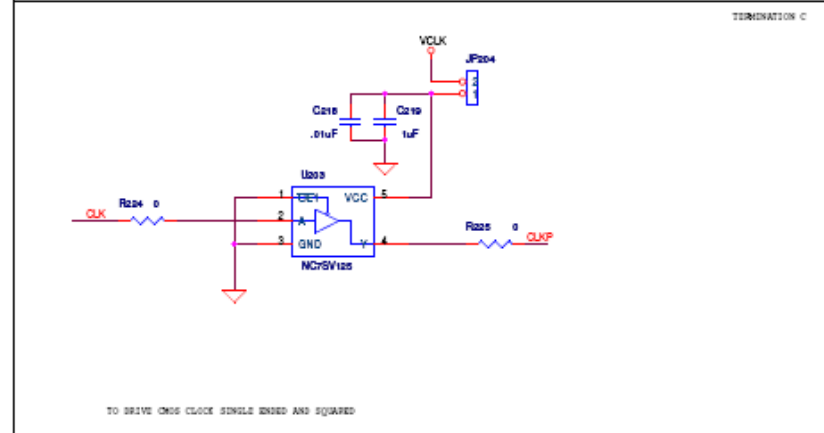

TO DRIVE CMOS CLOCK SINGLE ENDED AND SQUARED

CLOCK TERMINATION/DRIVER TO PUT (SELECT ONLY ONE OF THE THREE, A TO C, NOT MULTIPLES)

DIFFERENTIAL CLOCK
TO USE MAIN; APPLY C210, C214 AND C217. REMOVE R222, R223, R224, R225 AND JP204

SINGLE ENDED CLOCK (IN BOTH TERMINATIONS B & C, POPULATE R223)
TO SEND THE SINGLE ENDED CLOCK TO THE PART DIRECTLY, POPULATE R222 AND R223.
REMOVE C210, C214, C217, R224, R225 AND JP204

TO SEND A SQUARED SINGLE-ENDED CLOCK, POPULATE R224, R224, R225 AND JP204.
REMOVE C210, C214, C217 AND R222

Title		ADC16D1500 EVALBOARD (CLOCK INPUTS)	
Size	Document Number	Rev	
C	<Doc>	A	
Date	Friday, January 09, 2009	Sheet	3 of 8

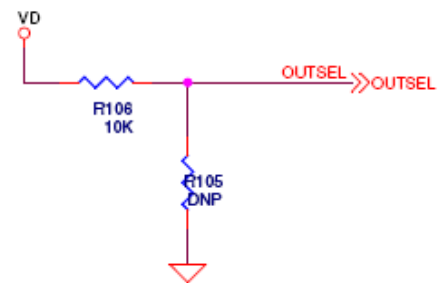
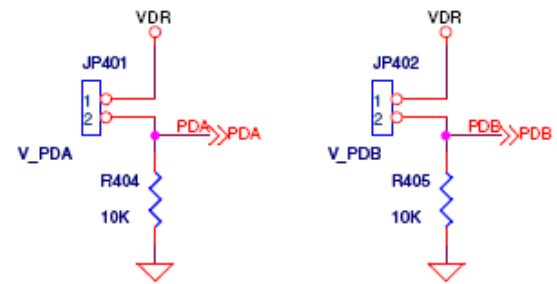
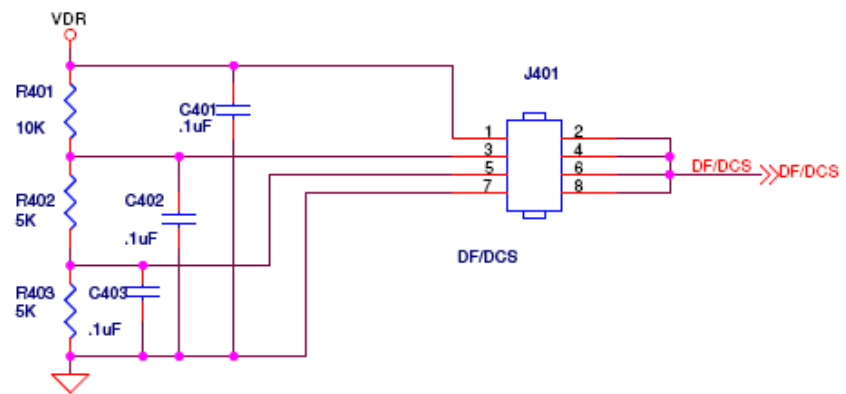

Title		
ADC10DV200 (DIGITAL INPUTS)		
Size	Document Number	Rev
B	<Doc>	A
Date:	Friday, January 09, 2009	Sheet 4 of 6

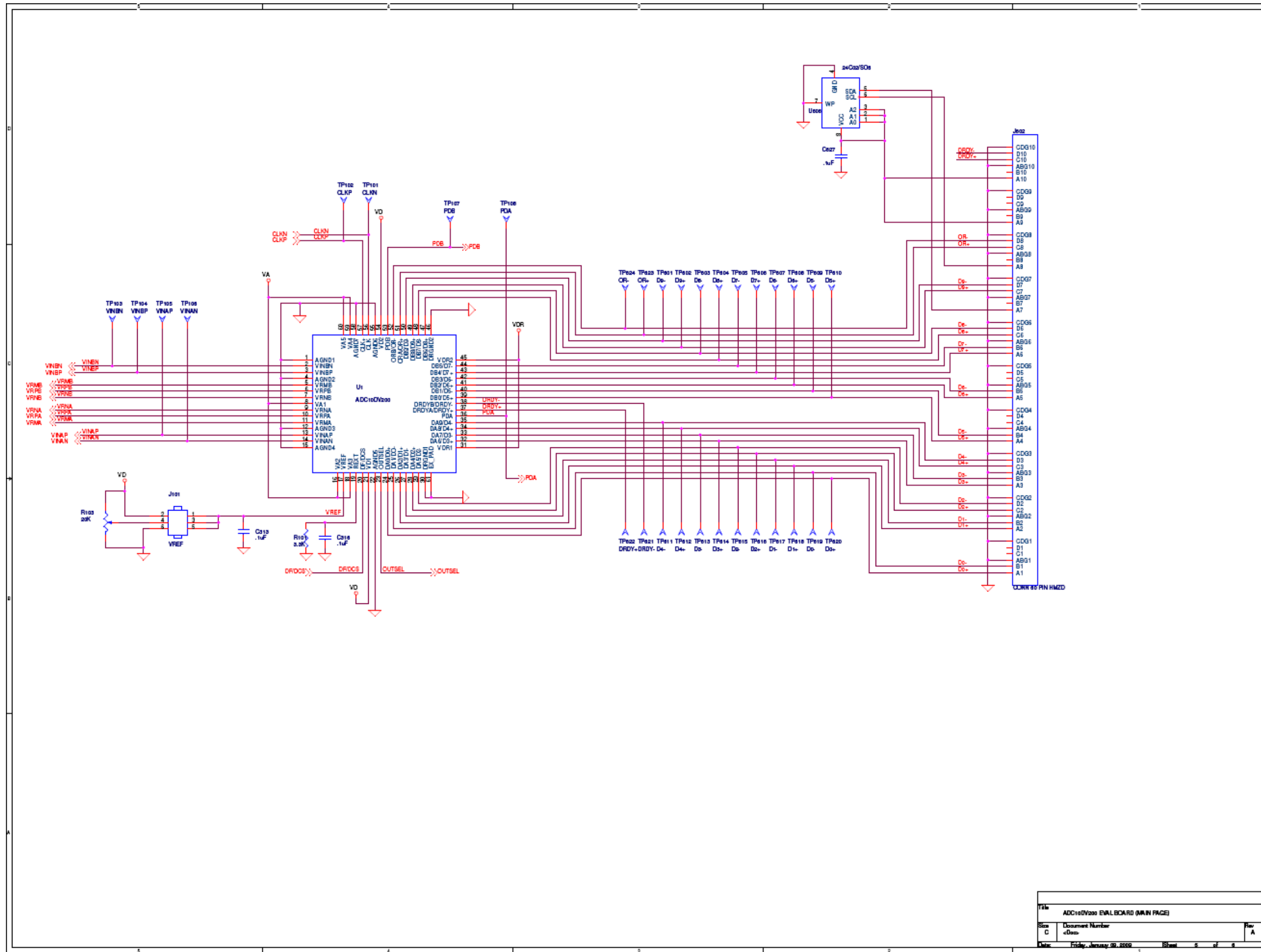

Title			ADC16D7300 EVALBOARD (MAIN PAGE)
Size	Document Number	Rev	
C	<Doc>	A	
Date	Friday, January 09, 2009	Sheet	5 of 8

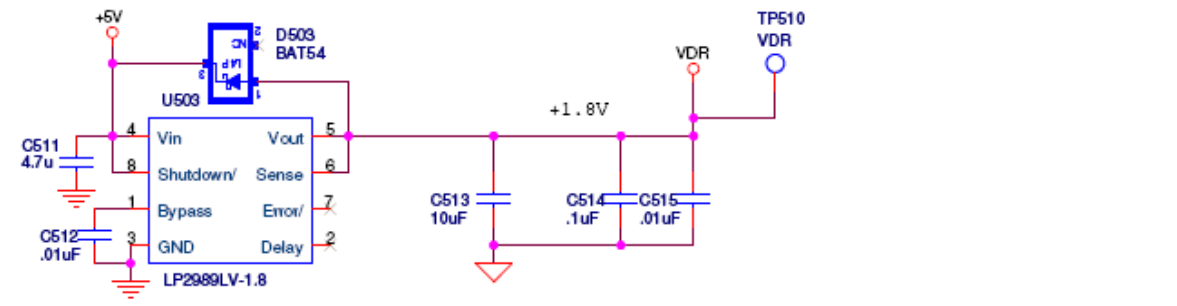
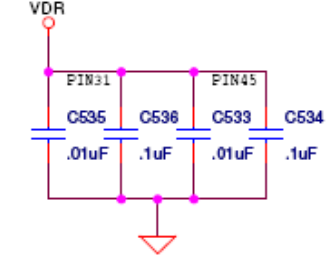
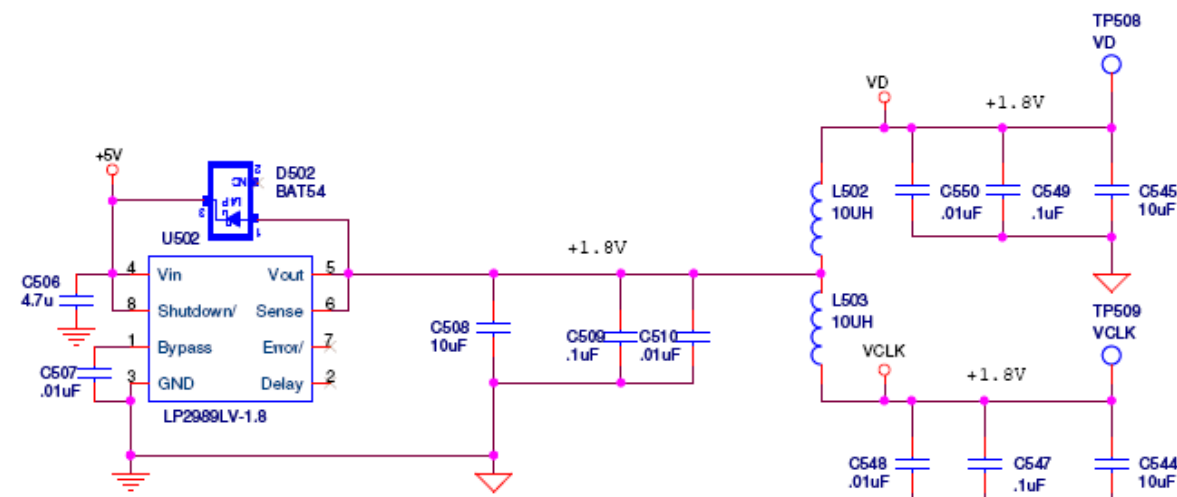
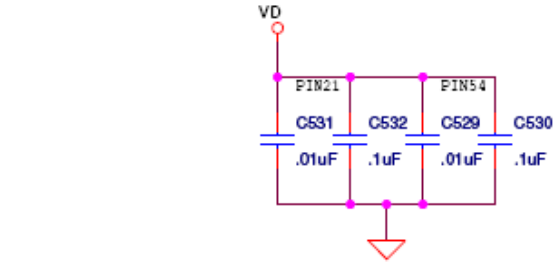
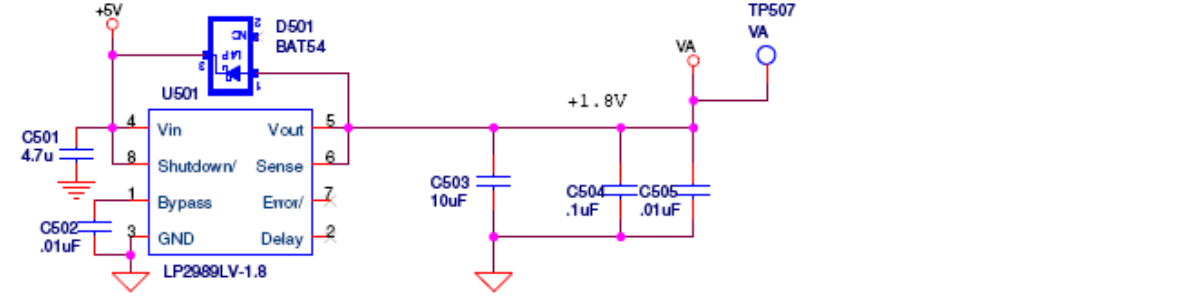
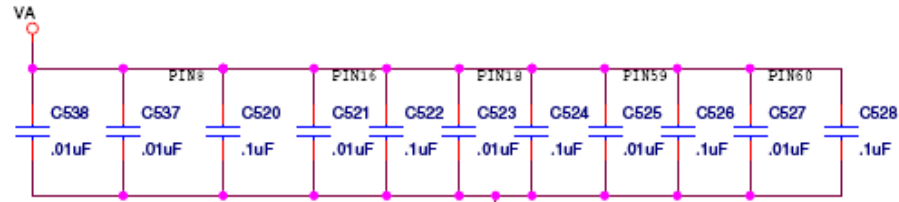
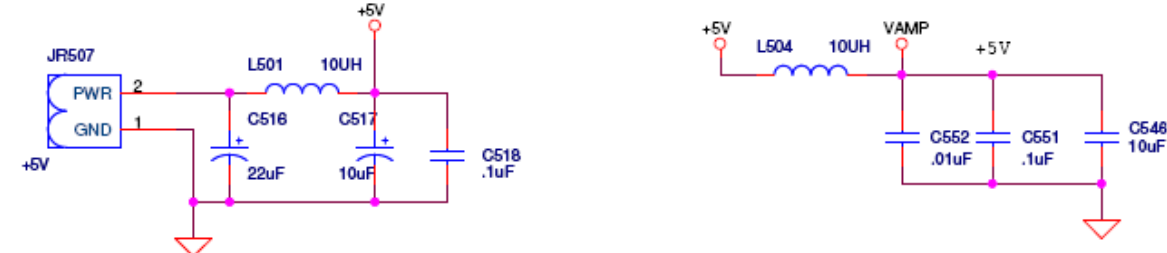

LIST OF POWER SUPPLIES:

NAME	VOLTAGE	FUNCTION
VA	1.8V	ANALOG POWER SUPPLY FOR CHIP
VD	1.8V	DIGITAL POWER SUPPLY FOR CHIP
VDR	1.8V	OUTPUT DRIVER POWER SUPPLY FOR CHIP
VCLK	1.8V	SUPPLIES ANY CLOCK COMPONENTS ON BOARD WITH 1.8V



Title ADC10DV200 EVAL BOARD (POWER SUPPLIES AND BYPASS CAPS)		
Size B	Document Number <Doc>	Rev A
Date: Friday, January 09, 2009	Sheet 6	of 6

7.0 Evaluation Board Layout

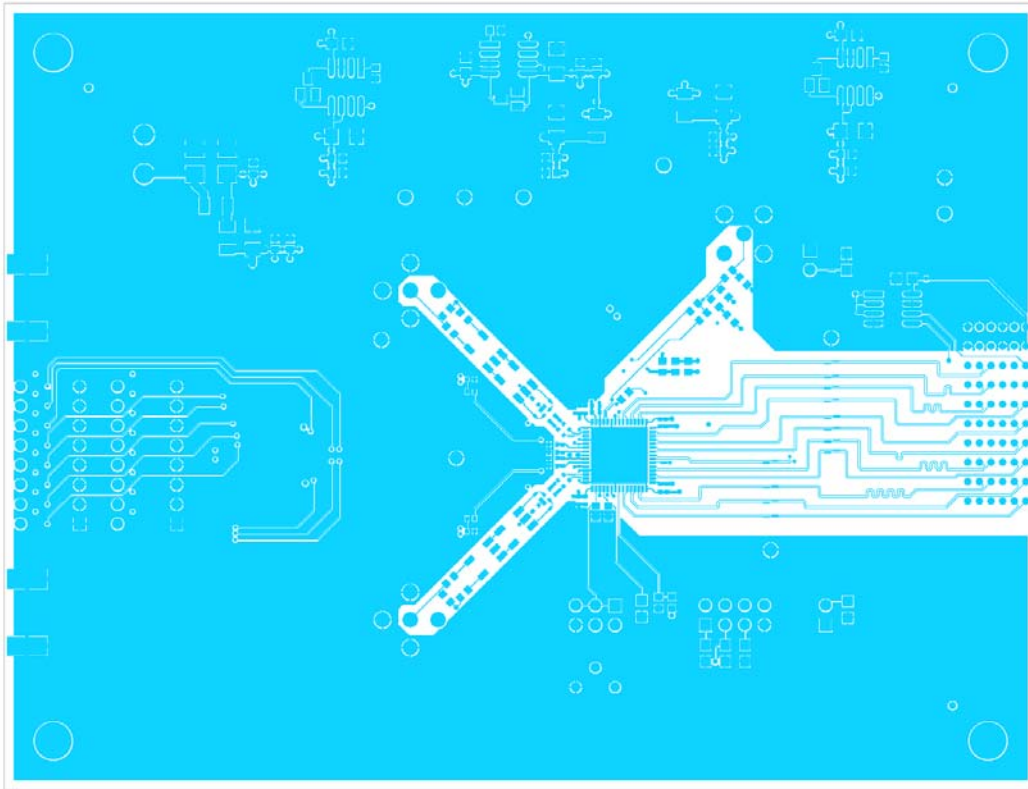

Layer 1 : Component Side

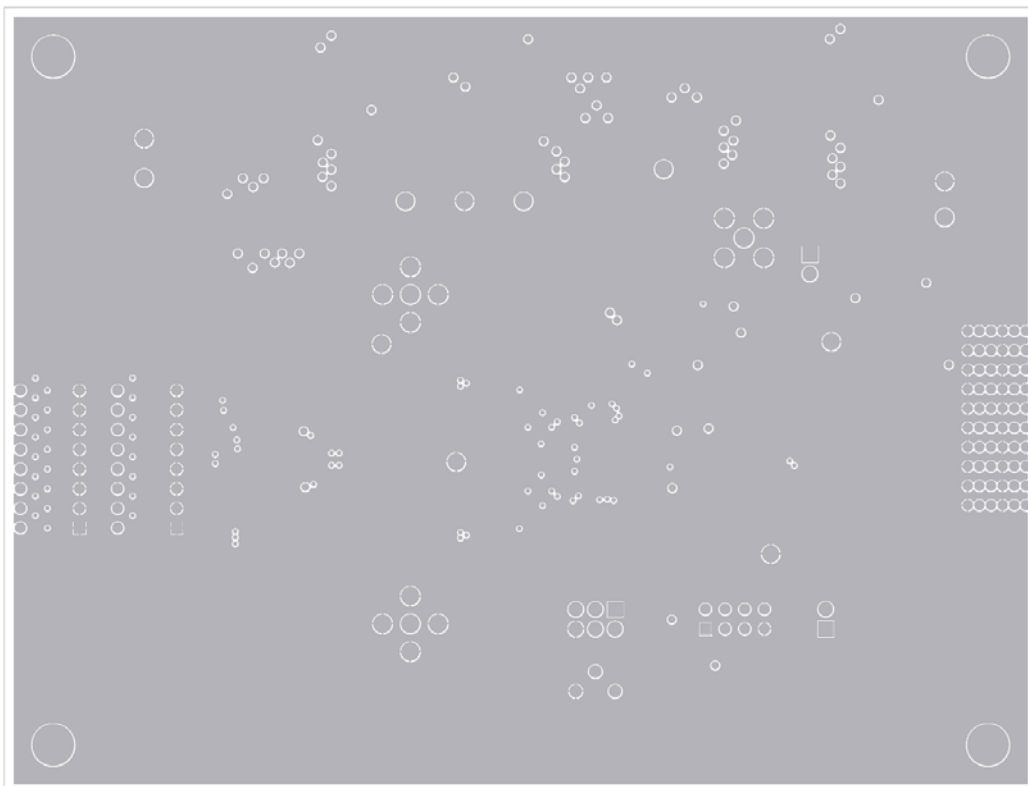

Layer 2 : Ground

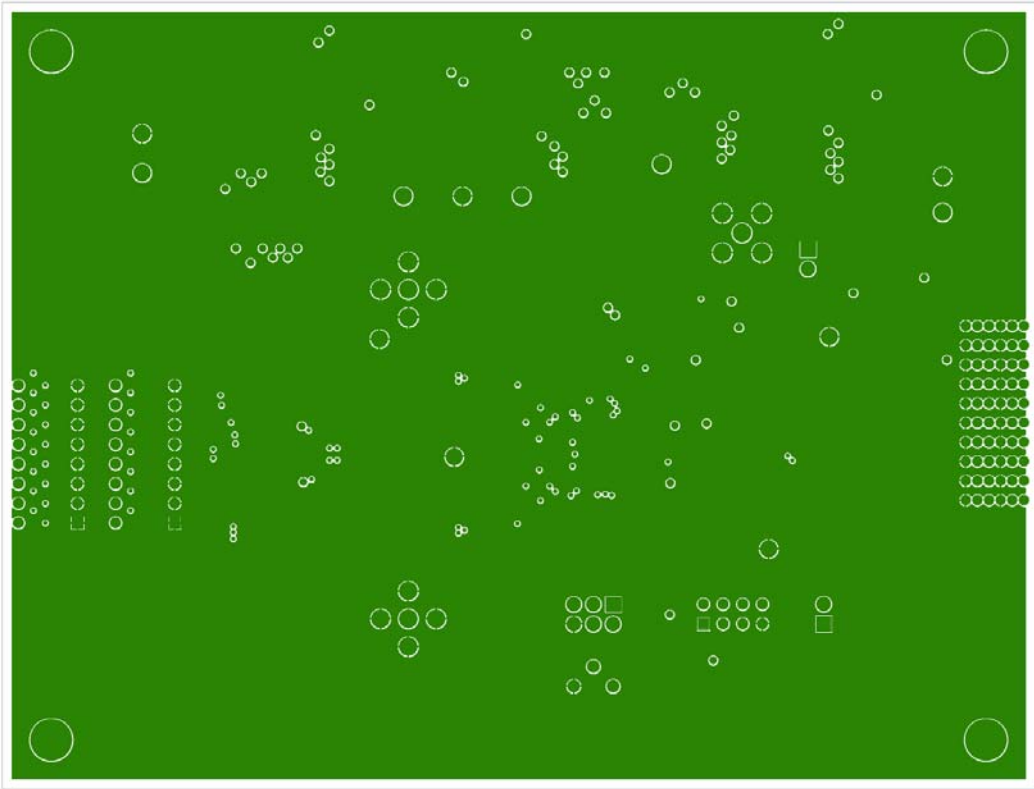

Layer 3 : Ground

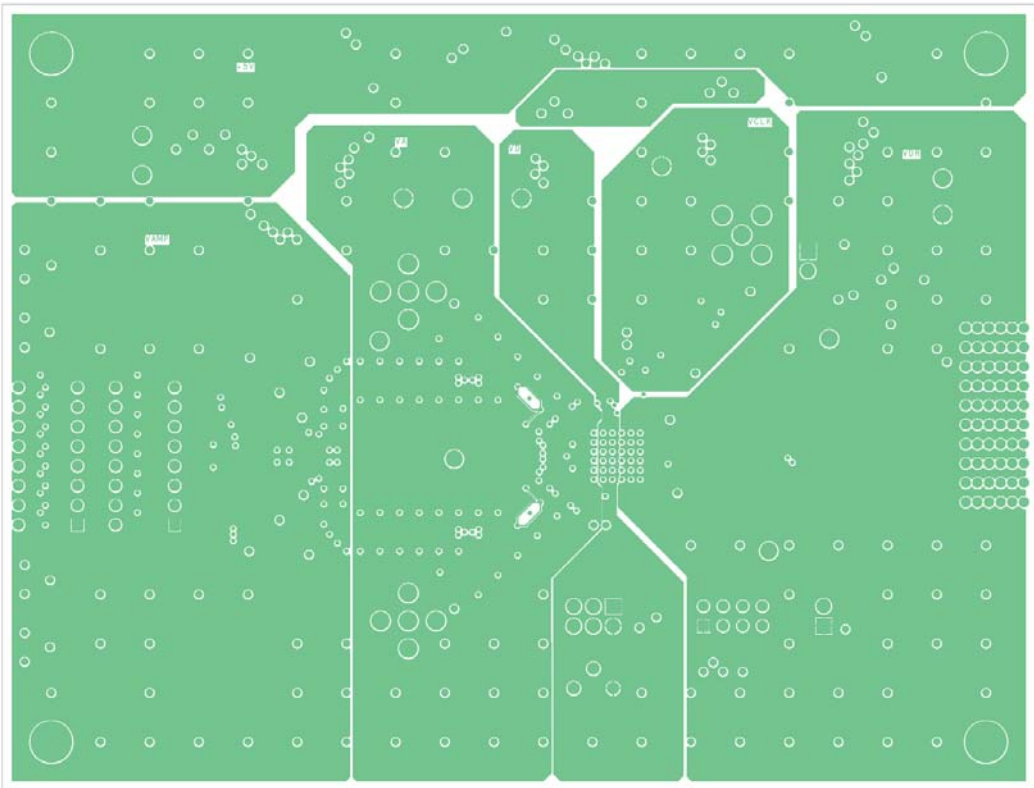

Layer 4 : Power

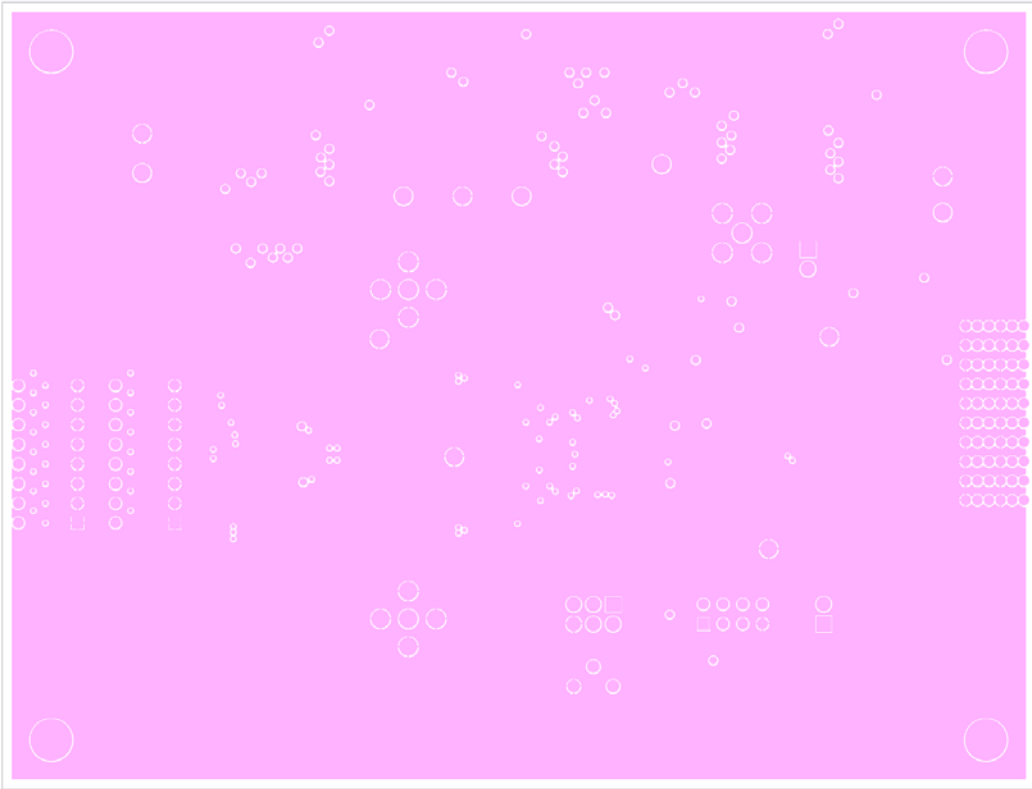

Layer 5 : Ground

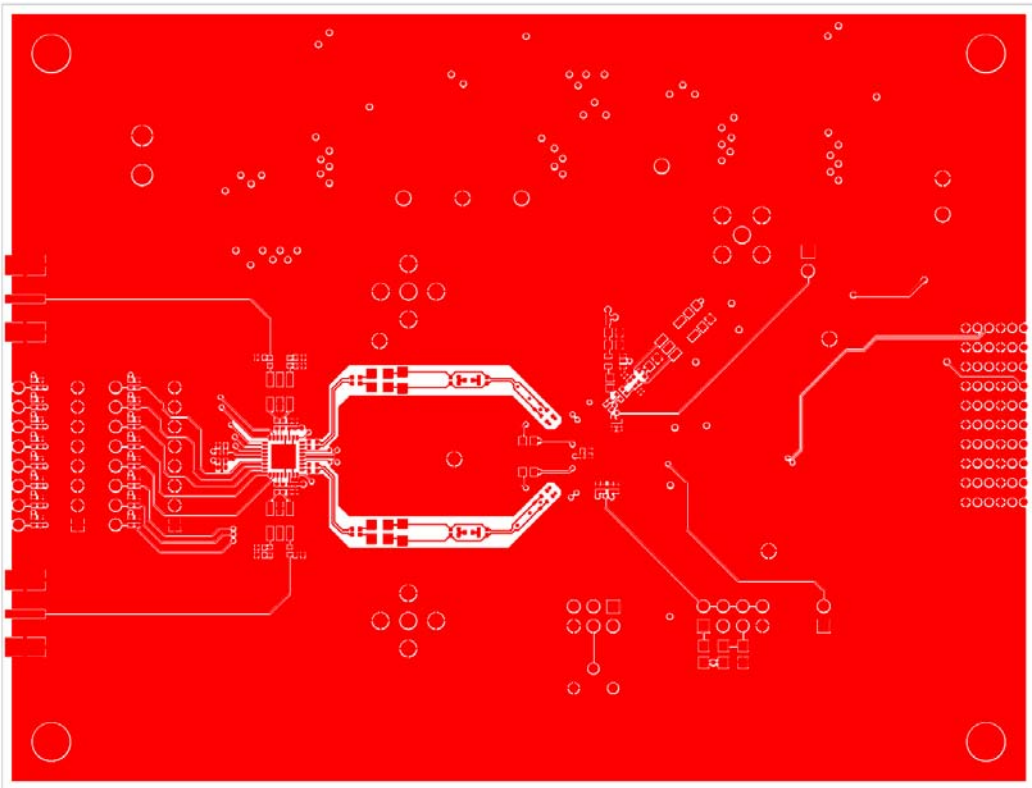

Layer 6 : Circuit Side

8.0 Evaluation Board Bill of Materials

Item	Qty	Reference	Part	Part Number	Vendor
1	15	C201,C220, C301,C302,C313,C314, C315,C316,C504,C509,C514, C518,C547,C549,C551	.1uF	PCC1762CT	Digi-Key
3	8	C305,C309,C311, C312,C318,C322,C324,C325,	.1uF	490-1318-1	Digi-Key
4	10	C218,C502,C505,C507,C510, C512,C515,C548,C550,C552	.01uF	PCC1784CT	Digi-Key
5	1	C219	1uF	PCC2224CT	Digi-Key
6	2	C307,C320	27pF	PCC270CQCT	Digi-Key
7	2	C310,C323	.1uF	PCC2336CT	Digi-Key
8	4	C401,C402,C403,C627	.1uF	PCC1828CT	Digi-Key
9	3	C501,C506,C511	4.7uF	PCC1842CT	Digi-Key
10	6	C503,C508,C513,C544,C545, C546	10uF	PCC1894CT	Digi-Key
11	1	C516	22uF	399-3717-1	Digi-Key
12	1	C517	10uF	399-3705-1	Digi-Key
13	9	C520,C522,C524,C526,C528, C530,C532,C534,C536	.1uF	PCC2146CT	Digi-Key
14	10	C521,C523,C525,C527,C529, C531,C533,C535,C537,C538	.01uF	PCC2270CT	Digi-Key
18	3	D501,D502,D503	BAT54	BAT54-FDICT	Digi-Key
19	1	JP204	HEADER 2	N/A	
20	1	JP401	V_PDA	S1011E-2	
21	1	JP402	V_PDB	S1011E-2	
22	1	JR507	+5V	277-1150	Digi-Key
23	1	J101	VREF	S2011E-3	
24	1	J201	EXT. CLK	ARFX1231	Digi-Key
25	1	J301	ANALOG IN B	ARFX1231	
26	1	J302	ANALOG IN A	ARFX1231	
27	1	J401	DF/DCS	S2011E-4	
29	1	J602	CONN 60 PIN HMZD	6469028-1	Digi-Key
31	4	L501,L502,L503,L504	10UH	490-1055-1	Digi-Key
34	1	R101	3.3K	311-3.3KARCT	Digi-Key
35	1	R103	20K	3296y-203LF	Digi-Key
37	1	R106	10K	311-10KGRCT	Digi-Key
38	1	R201	49.9	P49.9HCT	Digi-Key
39	2	R202,R203	1K	P1.00KHCT	Digi-Key
40	6	R218,R219,R304,R311,R313, R316	24.9	P24.9LCT	Digi-Key
41	2	R220,R221	10K	P10.0KHCT	Digi-Key
42	2	R224,R225	0	311-0.0GRCT	Digi-Key
43	4	R302,R303,R309,R310	30	311-30JRCT	Digi-Key
44	4	R305,R307,R312,R314	0	311-0.0JRCT	Digi-Key
45	2	R306,R315	49.9	311-49.9HRCT	Digi-Key

46	3	R401,R404,R405	10K	311-10KARCT	Digi-Key
47	2	R402,R403	5.1K	311-5.1KARCT	Digi-Key
70	6	TP501,TP502,TP503,TP504, TP505,TP506	GND	5002K	Digi-Key
71	1	TP507	VA	5002K	Digi-Key
72	1	TP508	VD	5002K	Digi-Key
73	1	TP509	VCLK	5002K	Digi-Key
74	1	TP510	VDR	5002K	Digi-Key
100	4	T301,T305,T302,T306	ETC1-1-13	ETC1-1-13	Richardson
102	1	U1	ADC10DV200 (or ADC11DV200)	ADC10DV200CISQ or ADC11DV200CISQ	
104	1	U203	NC7SV125	NC7SV125P5X	Mouser
105	3	U501,U502,U503	LP2989LV-1.8	LP2989AIM-1.8	Digi-Keys
107	1	U606	24C02/SO8	511-M24C02-WMN6P	Mouser
DO NOT POPULATE					
100	1	U201	ETC1-1-13	ETC1-1-13	Richardson
101	2	T307,T308	MABACT0040	MABACT0040	Richardson
36	3	R105,R301,R308	DNP		
42	2	R222,R223	0	311-0.0GRCT	Digi-Key
2	3	C213,C214,C215	DNP		
3	2	C216,C217	.1uF	490-1318-1	Digi-Key
1	4	C210,C211,C212,C221	.1uF	PCC1762CT	Digi-Key
106	1	U601	LMH6517	LMH6517SQ	National
28	1	J601	INPUT A	WM5534	Digi-Key
30	1	J607	INPUT B	WM5534	Digi-Key
48	4	R601,R602,R640,R642	DNP		
56	2	SW1,SW2	SW DIP-8	GH7176	Digi-Key
99	2	T1,T2	TCM4-19+	TCM4-19+	Mini-Circuits
50	18	R611,R612,R613,R614,R615, R616,R617,R618,R627,R628, R629,R630,R631,R632,R633, R634,R637,R638	20K	P20.0KLCT	Digi-Key
49	16	R603,R604,R605,R606,R607, R608,R609,R610,R619,R620, R621,R622,R623,R624,R625, R626	10K	311-10KJRCT	Digi-Key
51	2	R635,R636	10K	311-10.0KLCT	Digi-Key
32	4	L601,L602,L604,L605	129nH	495-3433-1	Digi-Key
33	2	L603,L606	1nH		
44	4	R653,R654,R655,R656	0	311-0.0JRCT	Digi-Key
52	2	R639,R641	0	311-0.0JRCT	Digi-Key
53	4	R643,R644,R645,R646	49.9	311-49.9LCT	Digi-Key
54	4	R647,R648,R649,R650	100	311-100JCT	Digi-Key
55	2	R651,R652	10	311-10JRCT	Digi-Key
3	10	C601,C602,C603,C604,C605, C606,C607,C608,C609,C611	.1uF	490-1318-1	Digi-Key
15	8	C610,C612,C613,C614,C615, C616,C623,C625	0.01uF	PCC103BQCT	Digi-Key
16	2	C617,C618	15pF	PCC150CQCT	Digi-Key
17	2	C624,C626	1uF	PCC2364CT	Digi-Key
6	4	C619,C620,C621,C622	27pF	PCC270CQCT	Digi-Key

APPENDIX

A1.0 Operating in the Computer Mode

The ADC10DV200 Evaluation Board is compatible with the WaveVision5™ Data Capture Board and WaveVision5™ software. You can download the latest version from: <http://www.national.com/analog/adc/wavevision5>

When connected to the WaveVision5™ Board, data capture is easily controlled from a personal computer operating in the Windows environment. The data samples that are captured can be observed on the PC video monitor in the time and frequency domains. The FFT analysis of the captured data yields insight into system noise and distortion sources and estimates of ADC dynamic performance such as SINAD, SNR and THD.

A2.0 Summary Tables of Test Points, Connectors, and Jumper Settings

A2.1 Test Points

Test Points on the ADC10DV200 Evaluation Board

Voltage Signal Name	Measure at	Nominal Voltage (V)	Voltage Limits (V)
VA	TP507	1.8	1.7 to 1.9
VD	TP508	1.8	1.7 to 1.9
VDR	TP510	1.8	1.7 to 1.9
VCLK	TP509	1.8	1.7 to 1.9

A2.2 Connectors

JR507 Connector - Power Supply Connections

1	GND	Power Supply Ground
2	+5V	+5V Power Supply

A2.3 Jumper settings

Note: Default settings are in **bold**

JP401 : Power Down Channel A

Connect 1-2	Channel A is in power down mode
1-2 OPEN	Channel A is in normal operation

JP402 : Power Down Channel B

Connect 1-2	Channel B is in power down mode
1-2 OPEN	Channel B is in normal operation

J401 : Output Data Format and Duty Cycle Stabilizer

Connect 1-2	Output format is offset binary, DCS is On
Connect 3-4	Output format is 2's complement, DCS is Off
Connect 5-6	Output format is offset binary, DCS is Off
Connect 7-8	Output format is 2's complement, DCS is On

A2.4 Clock Circuit Solder Jumper settings

Components can be installed or removed to select the path of the clock to the ADC. While not as convenient as pin-type jumpers, these introduce less distortion into the clock signal.

Termination A: Differential Sinusoid	Install C210, C216, and C217 Remove R223, R224, R225, and JP204
Termination B: Single Ended Sinusoid	Install R222 and R223 Remove C210, C216, C217, R224, R225 and JP204
Termination C: Single Ended Square	Install R223, R224, R225, and JP204 Remove C210, C216, C217, and R222

BY USING THIS PRODUCT, YOU ARE AGREEING TO BE BOUND BY THE TERMS AND CONDITIONS OF NATIONAL SEMICONDUCTOR'S END USER LICENSE AGREEMENT. DO NOT USE THIS PRODUCT UNTIL YOU HAVE READ AND AGREED TO THE TERMS AND CONDITIONS OF THAT AGREEMENT. IF YOU DO NOT AGREE WITH THEM, CONTACT THE VENDOR WITHIN TEN (10) DAYS OF RECEIPT FOR INSTRUCTIONS ON RETURN OF THE UNUSED PRODUCT FOR A REFUND OF THE PURCHASE PRICE PAID, IF ANY.

The ADC10DV200 Evaluation Boards are intended for product evaluation purposes only and are not intended for resale to end consumers, is not authorized for such use and is not designed for compliance with European EMC Directive 89/336/EEC, or for compliance with any other electromagnetic compatibility requirements.

National Semiconductor Corporation does not assume any responsibility for use of any circuitry or software supplied or described. No circuit patent licenses are implied.

LIFE SUPPORT POLICY

NATIONAL'S PRODUCTS ARE NOT AUTHORIZED FOR USE AS CRITICAL COMPONENTS IN LIFE SUPPORT DEVICES OR SYSTEMS WITHOUT THE EXPRESS WRITTEN APPROVAL OF THE PRESIDENT OF NATIONAL SEMICONDUCTOR CORPORATION. As used herein:

1. Life support devices or systems are devices or systems which, (a) are intended for surgical implant into the body, or (b) support or sustain life, and whose failure to perform, when properly used in accordance with instructions for use provided in the labeling, can be reasonably expected to result in a significant injury to the user.
2. A critical component is any component in a life support device or system whose failure to perform can be reasonably expected to cause the failure of the life support device or system, or to affect its safety or effectiveness.

**National Semiconductor Corporation
Americas**

Tel: 1-800-272-9959
Fax: 1-800-737-7018
Email: support@nsc.com

National Semiconductor Europe

Fax: +49 (0) 1 80-530 85 86
Email: europe.support@nsc.com
Deutsch Tel: +49 (0) 699508 6208
English Tel: +49 (0) 870 24 0 2171
Français Tel: +49 (0) 141 91 8790

**National Semiconductor
Asia Pacific Customer
Response Group**

Tel: 65-2544466
Fax: 65-2504466
Email: sea.support@nsc.com

**National Semiconductor
Japan Ltd.**

Tel: 81-3-5639-7560
Fax: 81-3-5639-7507

www.national.com

National does not assume any responsibility for any circuitry described, no circuit patent licenses are implied and National reserves the right at any time without notice to change said circuitry and specifications.