

Evaluation Board Instruction Manual

ADC08100 8-Bit, 20 Mps to 130Mps, Analog-to-Digital Converter with Internal Sample & Hold

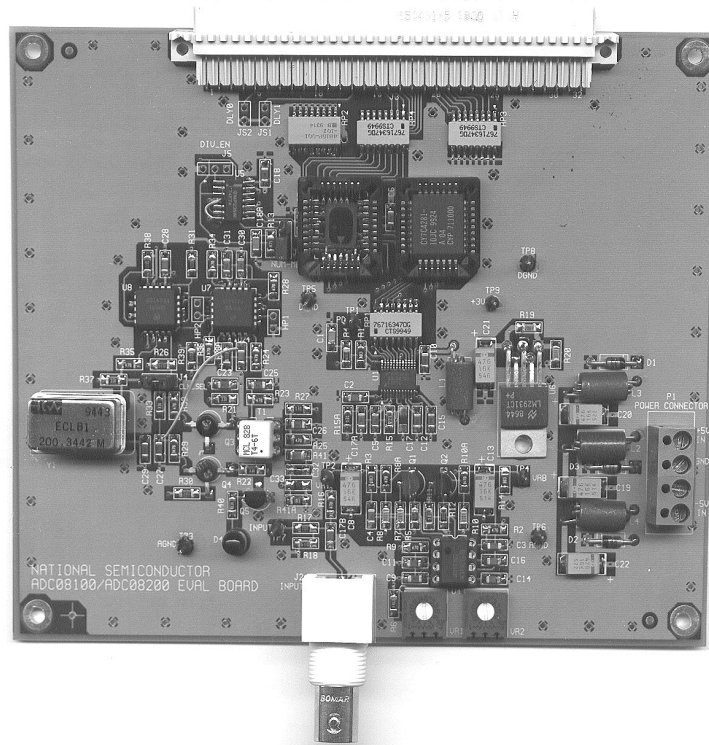

[Blank Page]

Table of Contents

1.0 Introduction.....	5
2.0 Board Assembly	5
3.0 Quick Start.....	5
4.0 Functional Description.....	6
4.1 Input (signal conditioning) circuitry	6
4.2 ADC reference circuitry	6
4.3 ADC clock circuit	6
4.4 Digital Data Output	7
4.5 Power Supply Connections	7
4.6 Power Requirements.....	7
5.0 Installing and Using the ADC08100 Evaluation Board	7
5.1 Software Installation	7
5.2 Setting up the ADC08100 Evaluation Board	7
5.2.1 Board Set-up	7
5.2.1.1 Computer Mode Operation.....	7
5.2.1.2 Manual Mode Operation.....	7
5.2.2 Quick Check of Analog Functions	7
5.2.3 Quick Check of Software and Computer Interface Operation.....	8
5.2.4 Getting Consistent Readings.....	8
5.2.5 Jumper Information	8
5.2.6 Troubleshooting.....	9
6.0 Evaluation Board Specifications	9
7.0 Hardware Schematic	10
8.0 Evaluation Board Bill of Materials.....	12
Summary Tables of Test Points and Connectors.....	13

[Blank Page]

1.0 Introduction

The ADC08100EVAL Design Kit (consisting of the ADC08100 Evaluation Board, National's WaveVision software and this manual) is designed to ease evaluation and design-in of National's ADC08100 8-bit Analog-to-Digital Converter, which operate at sample rates up to 130 Msps.

The WaveVision software operates under Microsoft Windows. The signal at the Analog Input is digitized and can be captured and displayed on the computer monitor as dynamic waveforms. The digitized output is also available at Euro connector J3.

The software can perform an FFT on the captured data upon command. This FFT display also shows dynamic performance in the form of SNR, SINAD, THD and SFDR.

Evaluation with this system is simplified by connecting the board to the WaveVision Digital Interface Board (order number WAVEVSN BRD 3.0), which is connected to a personal computer through a serial communication port and running WaveVision software, operating under Microsoft Windows. Use program WAVEVSN2.EXE

The signal at the Analog Input to the board is digitized and is available at pins B16 through B19 and C16 through C19 of J3. Pins A16 through A21 of J3 are ground pins.

Provision is made for adjustment of the Reference Voltages, V_{RT} and V_{RB} with potentiometers VR1 and VR2, respectively. These voltages are not regulated and will vary with the input potential at pin 1 of Power Connector P1.

2.0 Board Assembly

The ADC08100 Evaluation Board may come pre-assembled or as a bare board that must be assembled. Refer to the Bill of Materials for a description of components, to *Figure 1* for major component placement and to *Figure 2* for the Evaluation Board schematic.

3.0 Quick Start

Refer to *Figure 1* for locations of test points and major components.

1. Connect the evaluation board to the Digital Interface Board (order number WAVEVSN BRD 3.0). See the Digital Interface Board Manual for operation of that board.
1. Install a 100 MHz (or lower) crystal into socket Y1. While the oscillator may be soldered to the board, using a socket will allow you to easily change clock frequencies.
2. Connect a clean power supply to the terminals of connector P1. Adjust power supply to voltages of +4.75V to +5.25V and -5.2V to -5.3V before connecting it to the board. Turn on the power and confirm that there is 3 Volts at the pins of inductor L1.
3. Use VR1 to set the top reference voltage (V_{RT}) for the ADC to 1.9V at TP2. Use VR2 to set the bottom reference voltage (V_{RB}) for the ADC to 0.3V at TP4.
4. Connect the jumper at J4 to pins 1 and 2 (those farthest from oscillator Y1).
5. Connect a signal of 1.6V_{P-P} amplitude from a 50-Ohm source to Analog Input BNC J2. The ADC input signal can be observed at TP7. Because of isolation resistor R17 and the scope probe capacitance, the input signal at TP7 will not have the same frequency response as the ADC input signal.
6. The Digital Interface Board should be set up for 40MHz operation with an 80MHz crystal installed. See the Digital Interface Board manual.
7. See the Digital Interface Board Manual for data gathering instructions.

NOTE: The FFT will not indicate the correct frequencies because this information is derived from the clock frequency selected on the Digital Interface Board. To show the correct frequency information on the FFT, double click on the FFT window to open the FFT Dialog Box, then click on "Frequency", then click on "OK". Alternatively, you may double click on the data capture window before performing the FFT and change the frequency at "Sampling Rate of This Data (MHz)" to 100 to indicate a 100MHz rate.

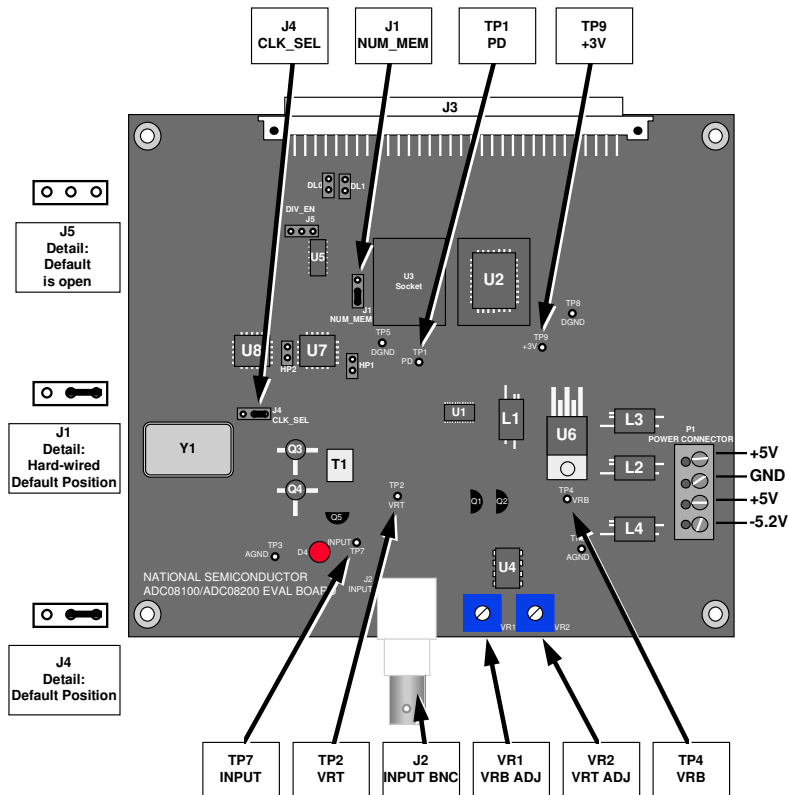

Figure 1. Component and Test Point Locations

4.0 Functional Description

The ADC08100 Evaluation Board schematic is shown in *Figure 2*.

4.1 Input (signal conditioning) circuitry

The input signal to be digitized should be applied to BNC connector J2. This 50 Ohm input is intended to accept a low-noise sine wave signal of 1.5V peak-to-peak amplitude. To accurately evaluate the ADC08100 dynamic performance, the input test signal should be passed through a high-quality bandpass filter (60dB minimum stop-band attenuation) as even the best generators do not provide a pure enough sine wave to properly evaluate an ADC.

Resistors R15, R15A, R16 and R18 provide the needed input bias to the ADC08100. You can center the input signal to the ADC by adjusting reference voltages V_{RT} and V_{RB} with VR1 and VR2 or by making slight adjustments to voltage an Power Connector pin 1.

4.2 ADC reference circuitry

The provided reference circuitry will provide nominal reference voltage ranges of 1.3V to 2.6V for V_{RT} and 0V to 1.3V for V_{RB} , Providing for nominal input ranges of 0V to 2.6V peak-to-peak. Note that this is beyond the maximum specified 2.3V range of the ADC08100.

The reference voltages for the ADC08100 can be monitored at test points TP2 and TP4 and are set with VR1 and VR2. Signal offset can be provided by adjusting both of these potentiometers, or by minor adjustments to the +5 Volts at pin 1 of Power Connector P1.

4.3 ADC clock circuit

The clock signal applied to the ADC is selected with jumper J4. A standard ECL-level 100 MHz crystal oscillator should be installed at Y1 and the divide by 2 function selected by shorting pins 1 and 2 of jumper JP4.

Caution: Be sure that the oscillator used has logic levels of -0.6V and -1.3V. We have found oscillators with levels that are too low to work properly in the circuit designed for this board.

R4 and C1 are used for high frequency termination of the clock line. An 80MHz clock oscillator should be used on the Digital Interface Board with that board's clock divider set for 2. See the Digital Interface Board manual for details.

4.4 Digital Data Output.

The digital output data from the ADC08100 is available at the 96-pin Euro connector J3. The series resistors of RP1 isolate the ADC from the load circuit to reduce noise coupling into the ADC.

4.5 Power Supply Connections

Power to this board is supplied through power connector P1. The only Voltages needed for the ADC08100 evaluation board are +5V and -5.2V supplies.

When using the ADC08100 Evaluation Board with the Digital Interface Board, the 5V logic power supply for the interface board is passed through the ADC01800 evaluation board from pin 3 of Power Connector P1. The supply voltages are protected by shunt diodes D1, D2 and D3. The +3 Volts needed for the ADC08100 is provided with voltage regulator U6, an LM2931CT.

4.6 Power Requirements

Voltage and current requirements for the ADC08100 Evaluation Board are:

- Pin 1 of P1: +5.0V \pm 5% at 100 mA
- Pin 3 of P1: +5.0V \pm 5% at 750mA.
- Pin 4 of P1: - 5.2V \pm 0.1V at 250 mA.

Pin 2 of P1 is ground. The +5V supply at pin 3 of the Power Connector P1 provides the power to the Digital Interface Board, where most of the power through this pin is consumed.

5.0 Installing and Using the ADC08100 Evaluation Board

The evaluation board requires power supplies as described in Section 4.6. An appropriate signal generator (such as the HP3325B, HP8662A or the Tektronix TSG130A) with 50 Ohm source impedance should be connected to the Analog Input BNC, J2, through a bandpass filter. The generator output should be filtered by a bandpass filter when evaluating sinusoidal signals to be sure there are no unwanted frequencies (harmonics and noise) presented to the ADC. A cable with a DB-9 connector must be connected between the Digital

Interface Board and the host computer. See the Digital Interface Board manual for details.

5.1 Software Installation

The WaveVision software provided requires 300k bytes of hard drive space and will run under Windows.

1. Insert the disk into a 3.5" floppy drive.
2. Copy the program WAVEVSN2.EXE to the desired subdirectory on you computer's hard disk and RUN it.

5.2 Setting up the ADC08100 Evaluation Board

This evaluation package was designed to be easy and simple to use, and to provide a quick and simple way to evaluate the ADC08100. The procedures given here will help you to properly set up the board.

5.2.1 Board Set-up

Refer to Figure 1 for locations of connectors, test points and jumpers on the board.

5.2.1.1 Computer Mode Operation

1. Be sure a 100MHz clock oscillator (Y1) is in place on the ADC08100 evaluation board and an 80MHz crystal is on the Digital Interface board.
2. Set jumper J4 to its default position, as shown in *Figure 1* to divide the clock oscillator frequency by two for the ADC08100.
3. Connect power to the board per requirements of section 4.6 and confirm that Red LED D4 on the ADC08100 evaluation board and D1 on the Digital Interface board are on, indicating clock presence.
4. Connect The ADC08100 evaluation board to Digital Interface Board, WAVEVSN RD 3.0.
5. Connect a cable with DB-9 connector between the Digital Interface Board connector P1 and a serial port on your computer.
6. Be sure jumper JP4 is set to divide the 100MHz clock by 2. This is the default position as shown in Figure 1.
7. Connect an appropriate signal source to BNC connector J2 of the ADC08100 evaluation board.

5.2.1.2 Manual Mode Operation

1. Perform steps 1 and 2 of section 5.2.1.1, above
2. Connect power to the board per requirements of section 4.6 is on, indicating clock presence.
3. Monitor the ADC08100 output at 96-pin connector J3 pins B16 through B19 and C16 through C19 (see appendix for pin configuration).
4. Clock the data out with a TTL clock of any speed up to 100 MHz at pin B25 of 96-pin connector J3.

5.2.2 Quick Check of Analog Functions

Refer to Figure 1 for locations of connectors, test points and jumpers on the board. If at any time the expected response is not obtained, see section 5.2.6 on Troubleshooting.

1. Perform steps 1 through 7 of Section 5.2.1.1. Adjust the input signal at J2 for 1.6V_{p-p}.
2. JP4 - Short the two pins farthest from Y1 (pins 1 & 2) to divide the on-board clock oscillator by 2 (Default position).
3. Turn on the power to the board.
4. Adjust VR1 for a voltage of 1.9V at TP2.
5. Adjust VR2 for a voltage of 0.3V at TP4.
6. Scope TP7 to be sure the input signal is present.
7. Adjust the signal source at Analog Input J1 for a signal amplitude of approximately 1.6V_{p-p}.

This completes the testing of the analog portion of the evaluation board.

5.2.3 Quick Check of Software and Computer Interface Operation

1. Perform steps 1 through 7 of Section 5.2.1.1, above.
2. Supply a 1.6V_{p-p} sine wave of about 10 MHz at Analog Input BNC J2.
3. Be sure there is an interconnecting cable between the board and your computer serial port.
4. RUN program WAVEVSN2.EXE.
5. After turning on power, be sure to wait for yellow LED D4 on the Digital Interface Board to go out before trying to acquire data or the board will "freeze" and you will have to cycle the power.
6. Acquire data by clicking on the ACQUIRE icon or by pressing ALT, P, A or CTRL-X. Data transfer and calculations can take a few seconds.
7. When transfer is complete, the data window should show many sine waves. The display may show a nearly solid area of red, which is O.K.
8. Double click on the data window and change the "Sampling Rate of this data (MHz)" to 100. This must be done each time another data capture is done or the frequency information in the FFT will not be correct.
9. With the mouse, you may click and drag to select a portion of the displayed waveform for better examination.
10. Click on the FFT icon or type ALT, P, E or CTRL-F to calculate the FFT of the data and display a frequency domain plot.

The FFT data will provide a measurement of SINAD, SNR, THD and SFDR, easing the performance verification of the ADC08100.

5.2.4 Getting Consistent Readings

Artifacts can result when we perform an FFT on a digitized waveform, producing inconsistent results when testing repeatedly. The presence of these artifacts means that the ADC under test may perform better than our measurements would indicate.

We can eliminate the need for windowing and get more consistent results if we observe the proper ratios between the input and sampling frequencies. This greatly increases the spectral resolution of the FFT, allowing us to more accurately evaluate the spectral response of the A/D converter. When we do this, however, we must be sure that the input signal has high spectral purity and stability and that the sampling clock signal is extremely stable with minimal jitter. Coherent sampling of a periodic waveform occurs when an integer number of cycles exists in the sample window. The relationship between the number of cycles sampled (CY), the number of samples taken (SS), the signal input frequency (f_{in}) and the sample rate (f_s), for coherent sampling, is

$$\frac{CY}{SS} = \frac{f_{in}}{f_s}$$

CY, the number of cycles in the data record, must be an integer number and SS, the number of samples in the record, must be a factor of 2 integer. For optimum results, CY should also be a prime number.

Further, f_{in} (signal input frequency) and f_s (sampling rate) should be locked to each other. If they come from the same generator, whatever frequency instability (jitter) is present in the two signals will cancel each other.

Windowing (an FFT Option under WaveVision) should be turned off for coherent sampling.

5.2.5 Jumper Information

Table 1 indicates the function and use of the jumpers on the ADC08100 evaluation board. Note that which pins of J5 are shorted (or whether any are shorted) is a "don't care" when 1 memory chip is used, which is the normal case for this board.

JUMPER	FUNCTION	PINS 1 & 2 SHORTED	PINS 2 & 3 SHORTED
J1 (Hard wired)	No of Mem Chips	1 Mem Chip	2 Mem Chips
J2	Input BNC	-	-
J3	not used	-	-
J4	Clock Select	Divide Clock by 2	Do not Divide Clock
J5 (Hard wired)	DIV_EN (No. of Mem Chips)	2 Mem Chips	1 Mem Chip

Table 1. Jumper settings.

5.2.6 Troubleshooting

"Comm Check Failed", "Error Transmitting", "Parallel Port Time Out Error" and/or "Failed to communicate with the board on LPT1" errors mean communication was unsuccessful. Try the following:

- Be sure to wait for yellow LED D4 on the Digital Interface Board to go out after turning on power before trying to capture data.
- Be sure that the Digital Interface Board is connected to a serial printer port and has power.
- Be sure the proper port is selected (type ALT-O).
- Ascertain that an 80MHz clock oscillator is properly inserted into the socket at Y1 of the Digital Interface Board. Check to see that LEDs D1 and D3 of the Digital Interface Board are on. See the Digital Interface Board manual for their functions.
- Be sure cable connections are solid.
- Be sure that the board to computer cable is not a Null Modem one. If it is, swap the jumpers on Digital Interface Board J8 and J10.
- Reset the evaluation board by pressing button S1 and try again.

If there is no output from the ADC08100, perform the following:

- Be sure that the proper voltages and polarities are present at Power Connector P1.
- Be sure +3 Volts is present at TP9.
- Be sure clock signal is present at J4 center pin.
- Be sure there is an input signal at TP7 and that the signal generator and input filter are of compatible frequencies.

If the displayed waveform appears to be garbage, or if the FFT plot shows nothing but noise with no apparent signal:

- Reset the evaluation board by pressing button S1 and try again.
- Be sure clock Y1 is of the proper frequency (100MHz) and type (ECL with output swing between -0.6V and -1.3V).
- Reset the board by pressing S1 and try again.

Problem Opening Comm Port" or "Error Setting Comm State" errors mean that the comm port selected is not the one to which the eval board is connected.

6.0 Evaluation Board Specifications

Board Size:	5" x 7" (12.7cm x 17.8 cm)
Power Requirements:	+ 5V \pm 5% @ 100 mA + 5V \pm 5% @ 750mA (see Section 4.6) - 5.2V.0 \pm 0.1V @ 250 mA
Clock Frequency Range:	40 MHz to 250 MHz (divided by 2 for the ADC)
Analog Input	
Nominal Voltage:	1.6V _{p-p}
Frequency Range	50 kHz to 150 MHz
Impedance:	50 Ohms

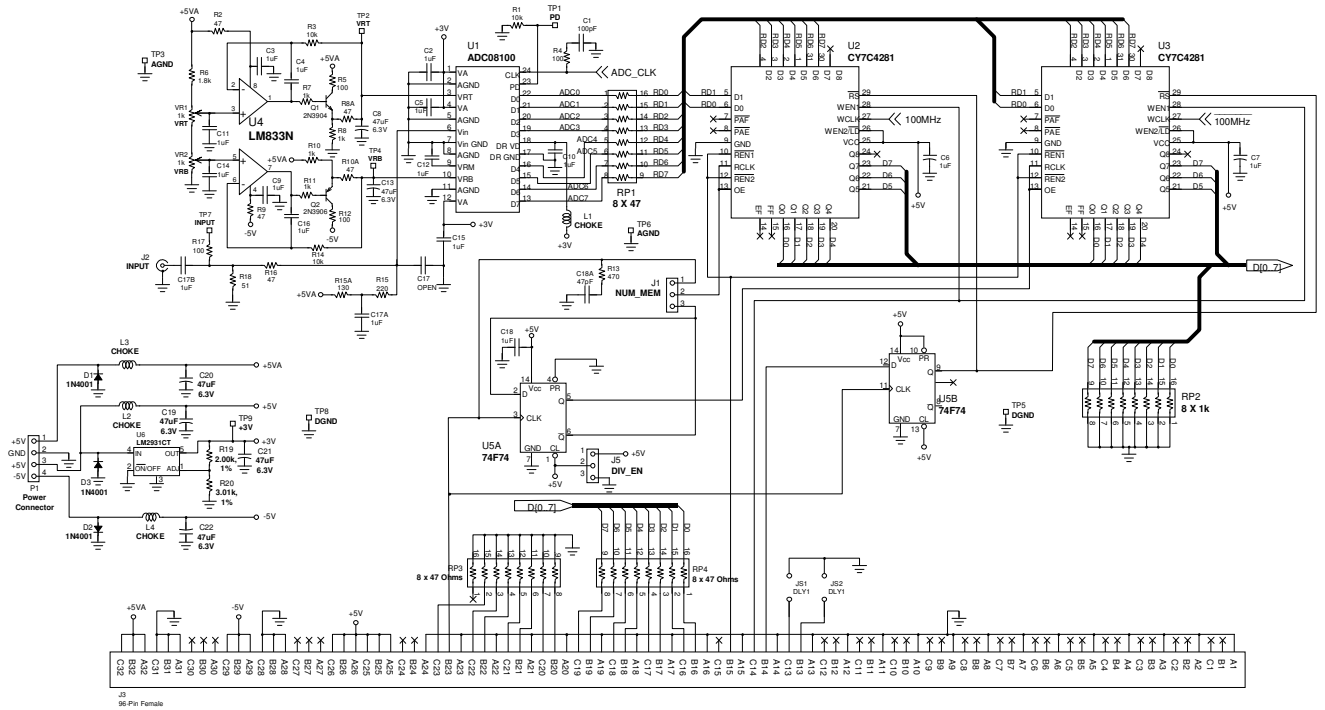

Figure 2a. ADC 08100 Evaluation Board Schematic

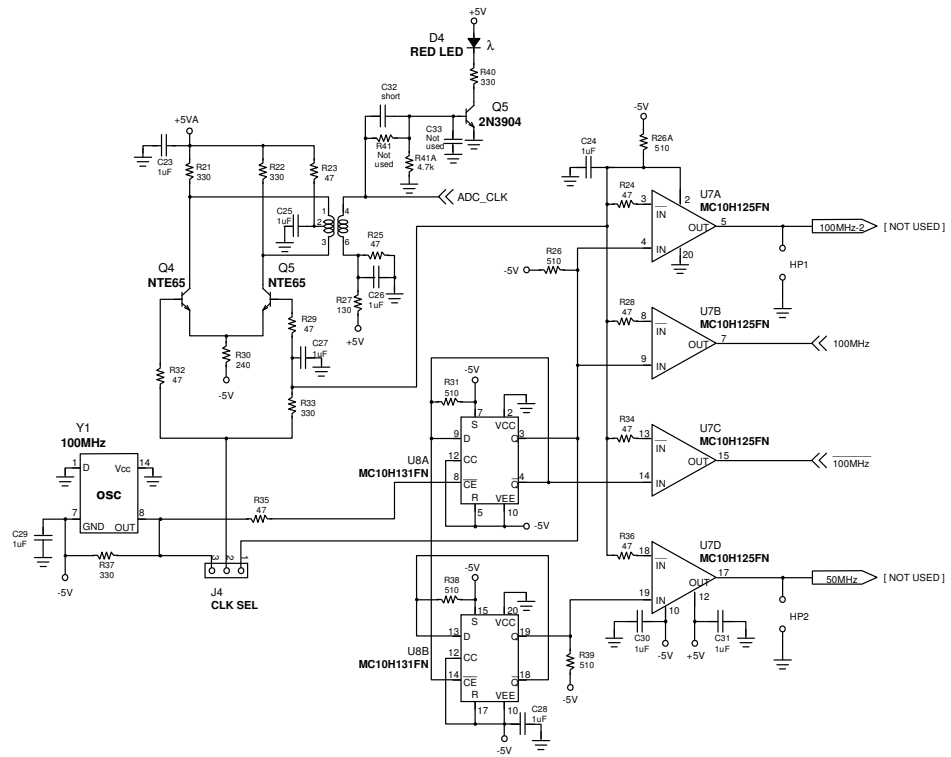

Figure 2b. ADC 08100 Evaluation Board Clock source

8.0 ADC08100 Evaluation Board Bill of Materials

<u>Item</u>	<u>Qty</u>	<u>Reference</u>	<u>Part</u>	<u>Source</u>
1	1	C1	10pF	Type 1206
2	25	C2, C3, C4, C5, C6, C7, C9, C10, C11, C12, C14, C15, C16, C17B, C17A, C18, C23, C24, C25, C26, C27, C28, C29, C30, C31	1uF	Type 1206
3	1	C32	Shorting Strap	
4	6	C8, C13, C19, C20, C21, C22	47uF, 6.3V	Type 7343 (D Size)
5	0	C17, C33	Open	Not Used
6	1	C18A	47pF	Type 1206
7	3	D1, D2, D3	1N4001	Various
8	1	D4	RED LED	DigiKey # 160-1124-ND
9	0	JS1, JS2, HP1, HP2, J5	Not Used	n/a
10	1	J2	BNC Connector	DigiKey # ARF1177-ND
11	2	J1, J4	3-Pin Post Headers	DigiKey # A19351-ND
12	1	J3	96-Pin Female	DigiKey # H7096-ND
13	4	L1, L2, L3, L4	Choke	DigiKey # M2204-ND
14	1	P1	Terminal Block	DigiKey # ED1609-ND
15	2	Q1, Q5	2N3904	Various
16	1	Q2	2N3906	Various
17	2	Q3, Q4	NTE65	NTE Electronics
18	3	RP1, RP3, RP4	Resistor Pack - 8 x 47	DigiKey # 766-163-R47-ND
19	1	RP2	Resistor Pack - 8 x 1k	DigiKey # 766-163-R1k-ND
20	3	R1, R3, R14	10k, 5%	Type 1206
21	14	R2, R8A, R9, R10A, R16, R23, R24, R25, R28, R29, R32, R34, R35, R36	47, 5%	Type 1206
22	4	R4, R5, R12, R17	100, 5%	Type 1206
23	1	R6	1.8k, 5%	Type 1206
24	4	R7, R8, R10, R11	1k, 5%	Type 1206
25	1	R13	470, 5%	Type 1206
26	1	R15	220, 5%	Type 1206
27	1	R15A	130, 5%	Type 1206
28	1	R18	51, 5%	Type 1206
29	1	R19	2.00k, 1%	Type 1206
30	1	R20	3.01k, 1%	Type 1206
31	5	R21, R22, R33, R37, R40	330, 5%	Type 1206
32	5	R26A, R26, R31, R38, R39	510, 5%	Type 1206
33	1	R27	130, 5%	Type 1206
34	1	R30	240, 5%	Type 1206
35	0	R41	Not Used	n/a
36	1	R41A	4.7k, 5%	Type 1206
37	1	TP1, TP2, TP3, TP4, TP5, TP6, TP7, TP8, TP9	Breakable Header	DigiKey # S1012-36-ND
38	1	T1	Signal Transformer	MiniCircuits type T4-6T
39	1	U1	ADC08100CIMTC	National Semiconductor
40	1	U2	CY7C4281-10JC or CY7C4291-10JC	Cypress Semiconductor
41	1	U4	LM833N	National Semiconductor
42	1	U5	74F74	Various
43	1	U6	LM2931CT	National Semiconductor
44	1	U7	MC10H125FN	ON Semiconductor
45	1	U8	MC10H131FN	ON Semiconductor
46	0	U3	Not Used	n/a
47	2	VR1, VR2	1k	DigiKey # 3386F-103-ND
48	1	Y1	100MHz	Low Jitter, ECL Output
49	1	32-Pin PLCC Socket	For U2	DigiKey # A2121-ND
50	1	8-Pin DIP Socket	For U4	DigiKey # A400-ND
51	1	6-Pin DIP Socket	For T1	DigiKey #AE8906-ND
52	1	4-Pin DIP Socket	For Oscillator Y1	DigiKey #A462-ND
53	3	Shorting Jumpers	For J4, JS1, JS2	DigiKey #S9601-ND

APPENDIX

Summary Tables of Test Points and Connectors

Test Points on the ADC08100 Evaluation Board

TP 1	Power Down Input. Pull high to power down the ADC08100
TP 2	ADC Top Reference Voltage
TP 3	Ground
TP 4	ADC Bottom Reference Voltage
TP 5	Ground
TP 6	Ground
TP 7	Signal Input test point
TP 8	Ground
TP 9	+3V Supply

P1 Connector - Power Supply Connections

J1-1	+5V	Positive Power Supply
J1-2	GND	Power Supply Ground
J1-3	+5V	Logic and Digital Interface Board Supply
J1-4	-5.2V	Negative Power Supply

J1 Connector - Number of Memory Chips Used (hard wired)

Connect 1-2	One Memory Chip (Default)
Connect 2-3	Two Memory Chips

J2 and JP3 - Not Used

J4 Connector - ADC Clock selection jumper settings

Connect 1-2	Divide frequency of Y1 by 2 (Default)
Connect 2-3	Use frequency of Y1

J5 Connector - Divide Enable

Connect 1-2	Two Memory Chips
Connect 2-3	One Memory Chip (Default)

J3 Connector - ADC Data Outputs - Connection to WaveVision Digital Interface Board

Signal	J2 pin number
ADC output D0	B16
ADC output D1	C16
ADC output D2	B17
ADC output D3	C17
ADC output D4	B18
ADC output D5	C18
ADC output D6	B19
ADC output D7	C19
ADC output D8	not used
ADC output D9	not used
ADC output D10	not used
ADC output D11	not used
GND	A1 thru A24, A28, B28, C28, A31, B31, C31
Memory Read Cock	B25
Reserved, Signal	B22, C22, C23
Reserved, Power	A25, A26, B25, B26, C25, C26 (+5V Logic Power Supply to Digital Interface Board)
Reserved, Power (-5.2V)	A29, B29, C29
Reserved, Power (+5V)	A32, B32, C32

[Blank Page]

BY USING THIS PRODUCT, YOU ARE AGREEING TO BE BOUND BY THE TERMS AND CONDITIONS OF NATIONAL SEMICONDUCTOR'S END USER LICENSE AGREEMENT. DO NOT USE THIS PRODUCT UNTIL YOU HAVE READ AND AGREED TO THE TERMS AND CONDITIONS OF THAT AGREEMENT. IF YOU DO NOT AGREE WITH THEM, CONTACT THE VENDOR WITHIN TEN (10) DAYS OF RECEIPT FOR INSTRUCTIONS ON RETURN OF THE UNUSED PRODUCT FOR A REFUND OF THE PURCHASE PRICE PAID, IF ANY.

The ADC08100 Evaluation Board is intended for product evaluation purposes only and is not intended for resale to end consumers, is not authorized for such use and is not designed for compliance with European EMC Directive 89/336/EEC.

WaveVision is a trademark of National Semiconductor Corporation. National does not assume any responsibility for use of any circuitry or software supplied or described. No circuit patent licenses are implied.

LIFE SUPPORT POLICY

NATIONAL'S PRODUCTS ARE NOT AUTHORIZED FOR USE AS CRITICAL COMPONENTS IN LIFE SUPPORT DEVICES OR SYSTEMS WITHOUT THE EXPRESS WRITTEN APPROVAL OF THE PRESIDENT OF NATIONAL SEMICONDUCTOR CORPORATION. As used herein:

1. Life support devices or systems are devices or systems which, (a) are intended for surgical implant into the body, or (b) support or sustain life, and whose failure to perform, when properly used in accordance with instructions for use provided in the labeling, can be reasonably expected to result in a significant injury to the user.
2. A critical component is any component in a life support device or system whose failure to perform can be reasonably expected to cause the failure of the life support device or system, or to affect its safety or effectiveness.

National Semiconductor Corporation Americas Tel: 1-800-272-9959 Fax: 1-800-737-7018 Email: support@nsc.com	National Semiconductor Europe Fax: +49 (0) 1 80-530 85 86 Email: europe.support@nsc.com Deutsch Tel: +49 (0) 699508 6208 English Tel: +49 (0) 870 24 0 2171 Français Tel: +49 (0) 141 91 8790	National Semiconductor Asia Pacific Customer Response Group Tel: 65-2544466 Fax: 65-2504466 Email: sea.support@nsc.com	National Semiconductor Japan Ltd. Tel: 81-3-5639-7560 Fax: 81-3-5639-7507
--	---	--	--

www.national.com

National does not assume any responsibility for any circuitry described, no circuit patent licenses are implied and National reserves the right at any time without notice to change said circuitry and specifications.