

Technology Edge

Communications System Power Supply Designs

By L. Haachitaba Mweene & Don Ashley of National Semiconductor

Communications infrastructure equipment employs a variety of power system components. Power factor corrected (PFC) AC/DC power supplies with load sharing and redundancy (N+1) at the front-end feed dense, high efficiency DC/DC modules and point-of-load converters on the back-end. A power efficient design is required that supplies both the higher voltage analog circuits and multiple tightly regulated low-voltage supplies for the high-speed digital communications ASICs and FPGAs.

More recently, diverse power supply requirements coupled with a volatile telecommunications market have forced equipment manufacturers to not only cut costs but to also provide more efficient and reliable power solutions in order to remain competitive.

This challenging business environment has spawned new distributed voltage bus standards, such as the recent +12V Intermediate Bus Architecture (IBA). The deployment of low-cost unregulated (open-loop) bricks to convert from the -48V bus to a standard +12V intermediate bus has allowed new low cost Point-of-load (POL) modules to be used. These small form factor POL modules, now available in Single In-line Package (SIP) and surface mount device package (SMD), provide a cost-effective means of providing systems loads with multiple low voltage supplies.

Competing with these new POL modules are hybrid isolated power supply topologies, such as the cascaded current-fed or voltage-fed push-pull converters. Semiconductor suppliers are enabling power supply system designers to embed low-cost compact isolated power supplies directly onto their motherboards and line cards. New highly integrated, high-voltage (100V) power ASICs such as the LM5041 Cascaded PWM, and LM5030 Push-Pull PWM controllers from National Semiconductor minimize the number of external components and printed circuit-board area required. Operating directly off the -48V bus, the cascaded converter can produce multiple low-voltage outputs with higher overall efficiency levels at a lower cost than multiple POL converters operating from a +12V intermediate bus converter.

The power supply designer must choose between buying off-the-shelf POL and IBC modules or attempting to reduce costs and improve efficiency by embedding a semiconductor manufacturer's power reference design. The cost-versus-design complexity and risk trade-offs are being reviewed more seriously than ever by information system manufacturers when developing new generations of cost-reduced equipment. Some will shy away from the embedded power solution -- despite the obvious cost and power savings -- if the power switches and integrated magnetic transformer introduce an uncomfortable level of PC board complexity.

For less complex applications requiring a single voltage supply, the added costs and complexities of the power transformer are minimal. More complex power supply applications with multiple output voltages require a more complex transformer having multiple secondary windings. Multiple output designs may also employ a complex regulation scheme which senses multiple outputs to control the feedback loop.

Voice-over-Internet-Protocol (VoIP), Digital Subscriber Line (DSL), and Third-generation (3G) base stations all necessitate varying degrees of complexity in power supply design. We discuss factors that influence power system design for these three applications below.

Voice-over-Internet Protocol (VoIP)

A VoIP DC-DC converter uses a less complex single high-power output transformer design (typ. 250-500W) to buffer the main -48V distribution bus. This minimizes the cost and the capacitance of bulk capacitors required to hold up the distribution bus voltage by narrowing the operating voltage to 43-57V from the traditional 36-72V range. Fault protection and safety isolation are also provided to all downstream converters or other loads on the distribution bus. Using these DC-DC converters with parallel outputs and load current-sharing, generates fault-tolerance (N+1) and heat distribution that are conducive to cooler operation, longer life-cycles and improved reliability.

VoIP converters generally require power supply circuit topologies that are performance-driven (highly efficient with minimal

conducted line current), easy to use and cost-effective with a small footprint and low profile. A number of topologies can be designed to meet these requirements to some degree. For example, the flyback converter with the advantage of topological simplicity, is often suggested. In contrast to buck-derived converters (e.g., the forward converter) the flyback does not require a transformer flux resetting mechanism or an output inductor. Offsetting these advantages, especially in a high-output voltage system such as the VOIP application, is the need for expensive capacitors to filter the large ripple current at the input and output. However, the ripple current problem of both flyback and forward converters can be mitigated by interleaving two converters in anti-phase. All things being equal, the input and output ripple currents in the interleaved system will be significantly less than those of a single converter.

A far better solution than the flyback converter for VOIP systems is the push-pull converter (Fig. 1). Fundamentally, a push-pull converter is the equivalent of two interleaved forward converters. But the push-pull converter has only one transformer, which is self-resetting, and only one output inductor, making it only slightly more complex than a single forward converter. The input ripple current is greatly reduced due to the interleaving effect, so smaller input inductors can be used. The output inductor attenuates the output ripple current allowing the use of less expensive capacitors with lower ripple current ratings. The flyback converter is often only suitable for up to about 150W, while the push-pull converter can perform satisfactorily in the kW power range.

More complex topologies can also be used in the VoIP application that offers better efficiency, especially at the extremes of the input voltage range. One example is the cascaded buck topology with a current-fed push-pull converter. (Note: the LM5041 dedicated PWM controller for this topology is now available.) This hybrid topology is an excellent choice at higher power levels and in situations where requirements for high efficiency and performance justify the additional cost.

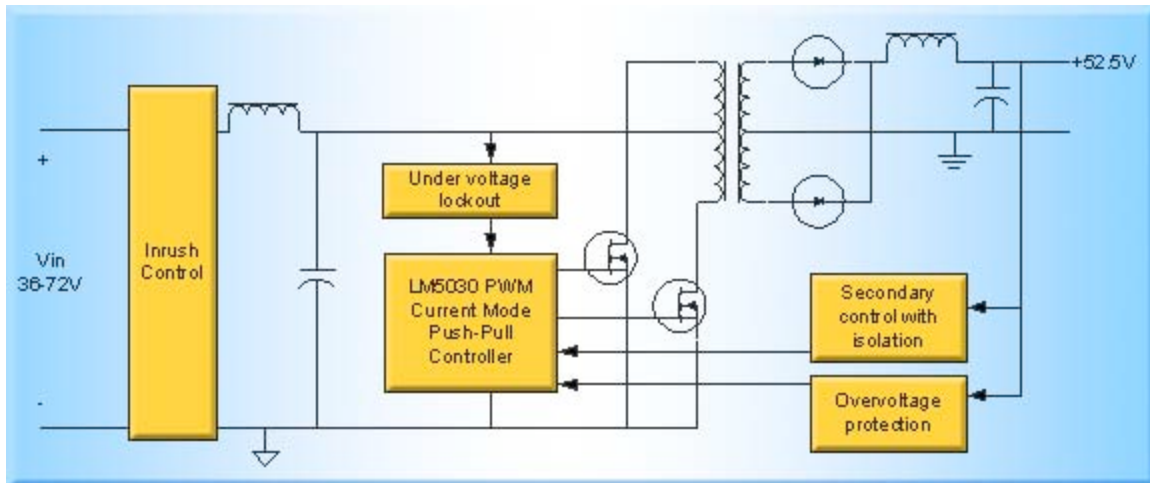

Fig. 1: Push-pull converter for VOIP applications

Digital Subscriber Line (DSL)

In a DSL application, a -48V to multiple output converter may be used which incorporates a more complex, lower power transformer (50-100W) with several outputs. The DSL power system may supply both higher voltage analog line drivers and amplifiers (typ. +/-12V) and several low voltage supplies required by the digital ASIC (+5V, +3.3V, +1.8V, +1.5V). Selection criteria for the power supply topology in multi-output DSL converters include requirements for performance (high efficiency and tight load and line regulation), simplicity, low cost and a small footprint with a low profile.

High performance is achieved by selecting the appropriate topology and control circuit. Choosing a topology supported by new controller IC's that integrate functions that were previously not included, simplifies the design by reducing the component count and associated board space. Low profile power supply design usually includes printed circuit board (planar) power transformers and output inductors and surface mount input and output capacitors.

Multiple output power supplies are often implemented with a multi-output flyback converter. While this approach is topologically one of the simplest, it suffers from poor load regulation of allu outputs except the controlled output. Flyback converter efficiency can be less than optimum because specialized ICs are not readily available to facilitate the use of synchronous rectification on low-voltage outputs where most of the power losses occur.

A preferred power supply architecture for DSL applications is illustrated in Fig. 2. A push-pull converter is used to convert the 48V input voltage to +/-12V and to provide electrical isolation. Synchronous buck converters powered off of the +12V rail generate various low-voltage outputs. This push-pull intermediate bus approach takes advantage of the availability of cost-effectiveness of power management ICs such as the LM5030 push-pull controller and the LM5642 two-channel current-mode synchronous buck controller. Each channel of the high-performance LM5642 needs only one pair of FETs, an output inductor, an output capacitor and a few resistors and capacitors.

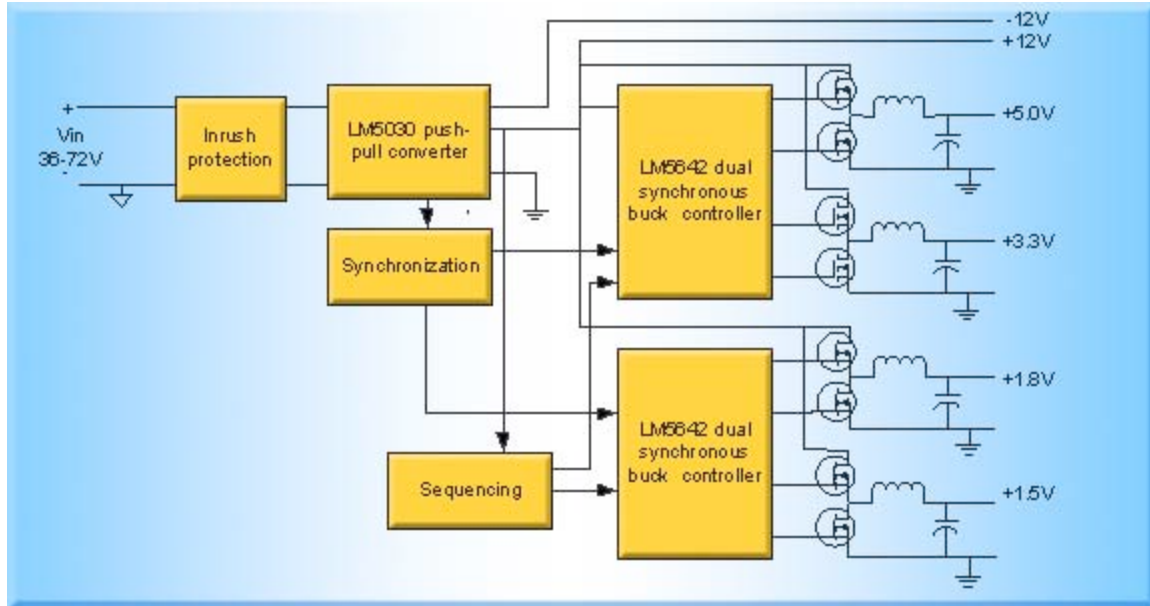

Fig. 2. Push-pull converter and synchronous bucks for multi-output applications

Third Generation (3G) Base Stations

In a 3G Base Station application, two converters are used to provide the +27V distribution bus voltage during normal conditions and power outages. A high-voltage converter powered directly from the main AC line powers the system during normal operation, while the second converter operates off of the -48V back-up batteries during power line black-outs. The -48V back-up battery converter is similar in construction and complexity to the single-output, high-power VoIP converter previously discussed. The power factor corrected (PFC) AC/DC produces the supply voltage for the 3G Base station's RF Power amplifier (typ. +27V) and the bus voltage for point-of-load converters.

The power supply topology illustrated in Figure 3 interleaves the main AC/DC converter with the battery back-up converter in a single stage DC-DC converter, thus eliminating an extra 400V to 48V DC-DC converter stage. This reduces costs while improving the overall system efficiency level.

A 27V DC bus voltage is generated using a dual FET forward converter. This forward converter has two upper FETs, each connected to a primary winding with the appropriate number of turns on the power transformer. Input voltage sensing logic turns on the top FET Q2, which is connected to the 400V bus, when the AC main supply voltage is within the correct range. During AC line power outages, top FET Q3 is activated to power the converter from the back-up battery. The resulting 27V distributed bus with battery back-up supplies voltage to the main power transmitter and a 3.3V brick that may be used to supply power to POL converters.

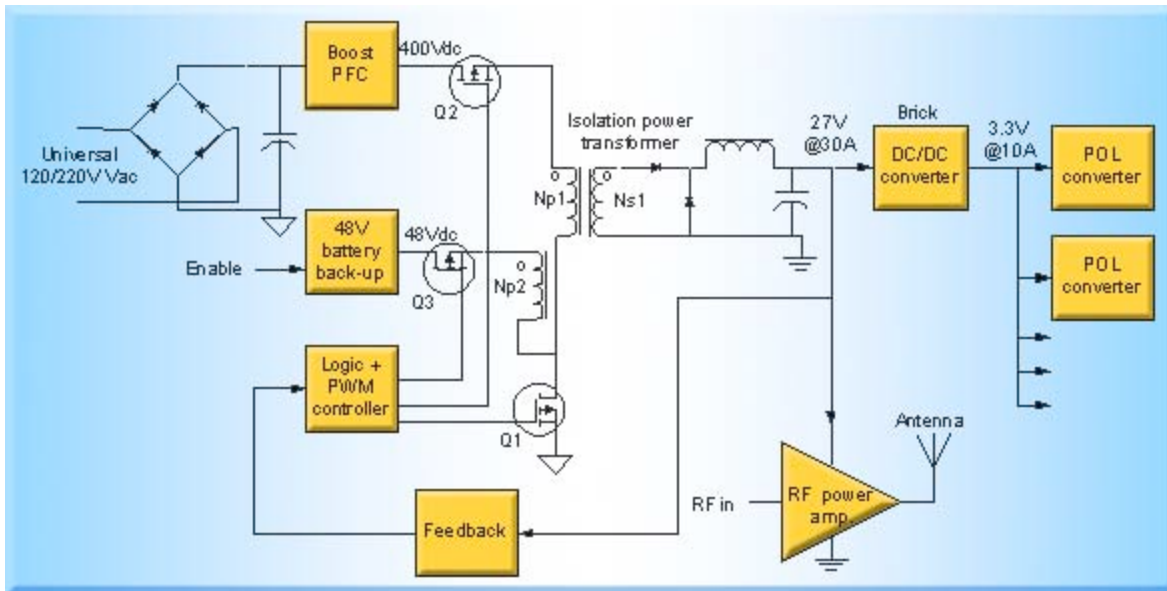

Fig. 3. 3G Base station RF power amp supply

Conclusion

These are three of the many telecommunication power supply applications that challenge power system designers to analyze a wide range of power distribution architectures and converter topologies. Unique solutions for DSL, VoIP and 3G Base Stations illustrate the wide range of power system architectures and the opportunities available for higher level integration. The input voltage range, number of outputs and power requirements along with goals for cost, performance, and size drive the design choices for each application.

Semiconductor manufacturers are introducing highly integrated controllers to reduce the cost of power modules and simplify the design of embedded converters. The pervasive pressure to reduce system costs will continue to stimulate architectural innovation and rapid evolution of power topologies.

Visit Power.National.Com for more information on National power product offerings.