

## Technology Edge

### A precision interface for a Resistance Temperature Detector (RTD)

Walter Bacharowski, Staff Applications Engineer

Resistance Temperature Detectors (RTDs) are temperature sensors that make use of the temperature dependence of a metal's resistance. They are used in a wide variety of temperature measurement and control instrumentation. These circuits are based on using a 100W Platinum RTD (PRTD), versions of which are readily available from many sources. A PRTD's transfer function of resistance vs. temperature, for temperatures greater than 0°C, are approximated by the equation:

$$R_{RTD} = (100 + 0.39083T - 0.00005775T^2)W$$

T = temperature

This article presents circuitry that minimizes the error contribution of the signal conditioning elements (see the schematic in Figure 1).

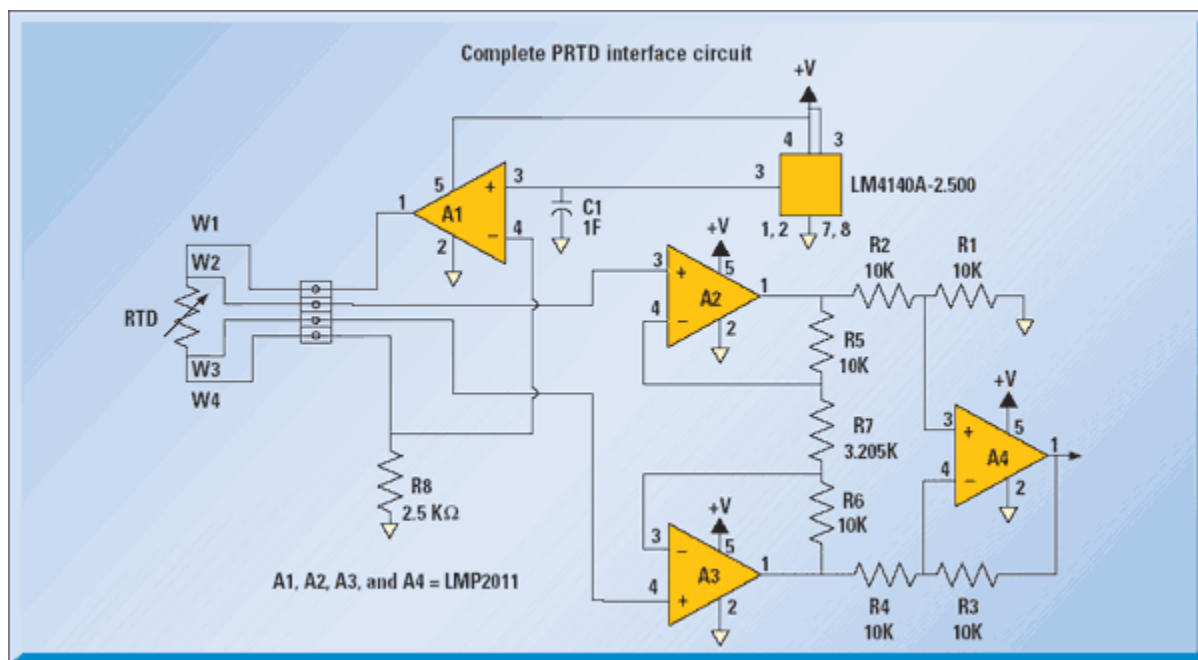

Figure 1

#### Component selection

The [LMP2011](#) precision amplifier is a high gain and almost zero offset voltage amplifier. The [LM4140A-2.500](#) is a trimmed, low drift, voltage reference with an error of less than 0.05% and a drift less than 10 PPM/°C. These components, along with several precision resistors assemble into a very accurate and stable thermometer.

The circuitry in Figure 1 is designed to take advantage of the four-wire PRTD, which is the most accurate configuration to use. The four-wire PRTD implements a Kelvin connection force and sense leads. The two wires (W1 and W4 in Figure 1) are the force leads and connect the RTD to the constant current source. The other two wires (W2 and W3) are the sense leads and connect voltage across the RTD to the amplifier. This arrangement separates the constant-current source driving the RTD from the measurement circuit. The voltage drop in the wires W1 and W4 are removed from the measurement of the voltage across the RTD.

As an example of the error that can be introduced by the lead wires: If a probe uses 10 feet of 24-gauge copper wire to connect the resistance element to the instrument, then the lead resistance is  $2 \times 10 \text{ ft} \times 0.0257 \text{ W/ft} = 0.514 \text{ W}$ . The resistance change of the RTD at 0°C is  $0.39 \text{ W/°C}$  and the lead wire represents a  $0.514 \text{ W} / 0.39 \text{ W/°C} = 1.31 \text{ °C}$  error. At

higher temperatures, the error will be larger. As an example, the resistance change of the PRTD at 400°C is 0.35 W/°C and the lead wire represents a 0.514W/0.35 W/°C = 1.46°C error.

### RTD exciter alternatives

The schematics in *Figure 2* and *Figure 3* show two alternatives for exciting the PRTD. *Figure 2* uses a constant-voltage source and a series resistor to set the current through the PRTD to a specific level at a specific temperature. In this example, the current is set to 1 mA at 0°C ( $2.5V/(100W + 2400W) = 0.001A$ ). This ignores the resistance of the leads W1 and W4. The voltage on the sense leads, W2 and W3, the result of a voltage divider, is  $V_{PRTD} = VR \times (R_{PRTD} / (R_{PRTD} + 2400W))$ .

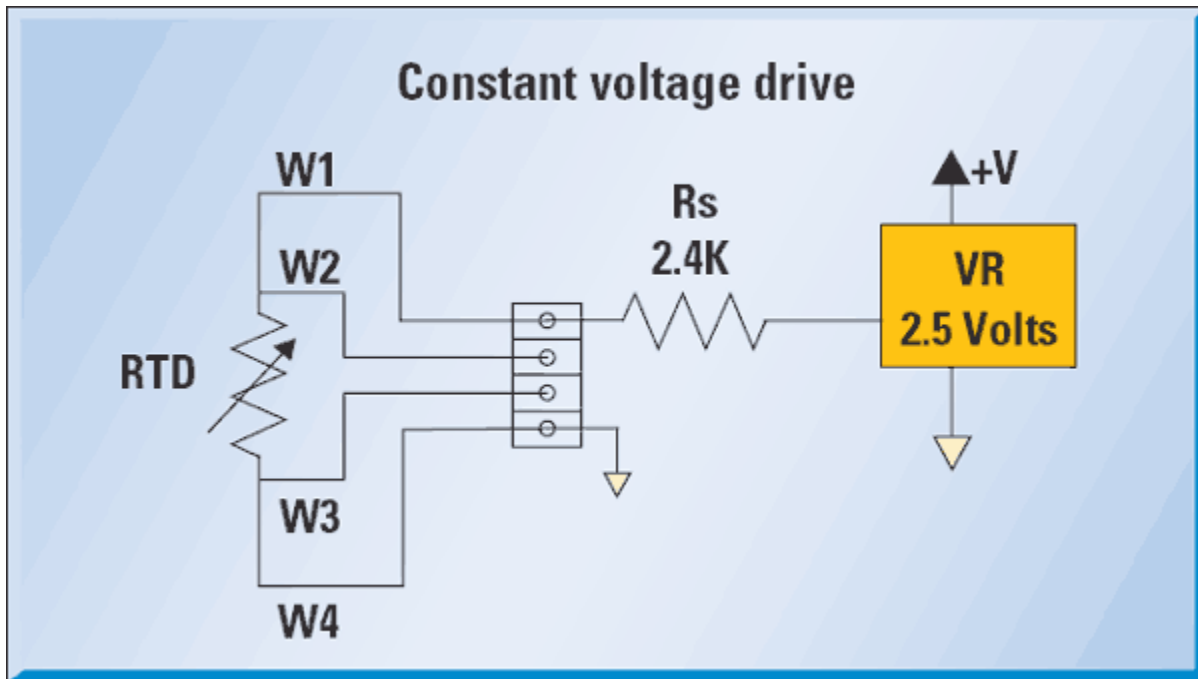

Figure 2

*Figure 3* uses a constant-current source. As long as the combined voltage of the leads drop, the PRTD and R8 does not exceed the maximum output swing of amplifier A1, and 1 mA will flow through the PRTD. The voltage on the sense leads, W2 and W3, is  $V_{PRTD} = 0.001 \times R_{PRTD}$ .

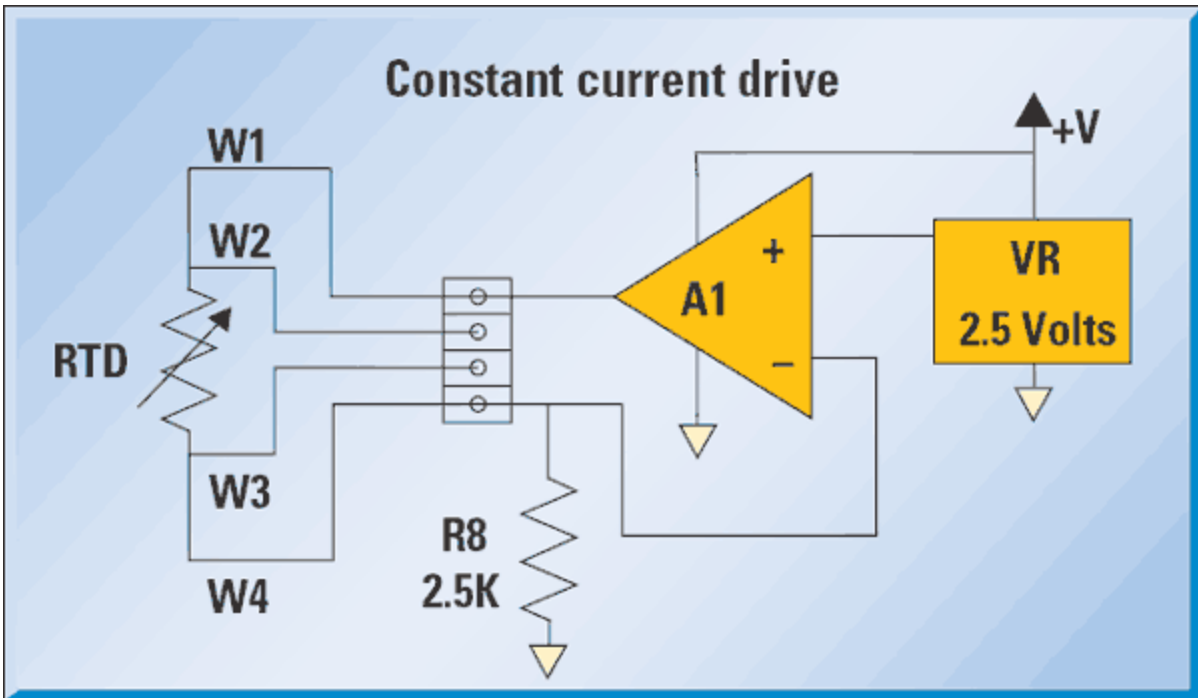

Figure 3

The graphs in *Figure 4* compare the results of the two methods. Curve 1 is the  $V_{PRTD}$  with constant-current drive and curve 2 is the  $V_{PRTD}$  with the constant-voltage drive. The constant voltage drive introduces additional nonlinearity because of the voltage divider effects.

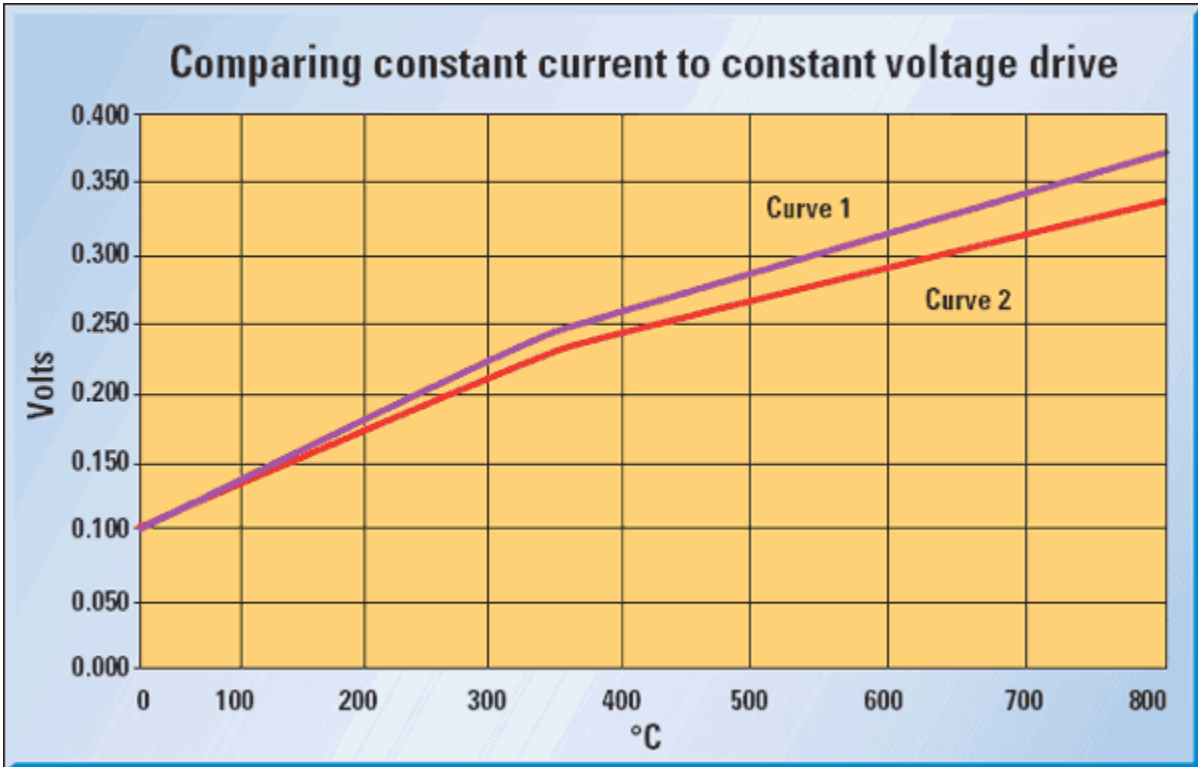

Figure 4

### The constant-current exciter

The constant-current source is made up of the amplifier A1, an [LMP2011](#) precision amplifier, resistor R8, and the 2.5V [LM4140](#) reference. The constant-current value is calculated by the equation:  $I_{RTD} = V_{REF}/R8$ . For the values used in *Figure 1*,  $I_{RTD} = 2.5V/2500\Omega = 1 \text{ mA}$ . In general, a current of 1 mA is small enough to minimize the self-heating error of the PRTD.

The amount of current forced through the RTD is a compromise between maximizing the sensitivity of the temperature sensor and minimizing the self-heating error caused by the current flowing through the RTD. RTD datasheets usually provide specifications on how much self-heating will occur under several different conditions. By changing the value of R8, other constant-current values can be used. The resistor, R8, directly affects the accuracy of the current source. It should be more accurate than the desired accuracy of the temperature measurement and be temperature-stable.

An effective implementation of the resistor R8 is to take advantage of packaged, trimmed, thin film resistor arrays. An accurate 2.5 KW can be assembled by using four 10KW resistors within the same package, wired in parallel.

### The signal amplifier

Amplifiers A2, A3, and A4 implement an instrumentation amplifier. In this example, the temperature range of interest is 0°C to 700°C, which translates to a resistance range of 100Ω to 345.28Ω. With a 1 mA current, voltage on the sense leads will range from 0.10V to 0.34528V. As an additional assumption, the [LM4140A-2.500](#) voltage reference is also used as the reference for an analog-to-digital converter and the PRTD signal will be scaled to 2.5 volts full scale. The required gain of the instrumentation amplifier is  $2.500/0.34528 = 7.2405$ . The overall gain of the instrumentation amplifier is given by the equation  $AV = (1+2R5 / R7) (R1 / R2)$ , with the restriction that  $R3 = R1$ ,  $R4 = R2$ , and  $R6 = R5$ . Because the gain required is relatively low, all the gain will be in the first stage and can be controlled by the value of R7. This gain setting also forces all of the remaining resistors to be equal. The resistors, R1, R2, R3, R4, R5, and R6 should be matched as closely as possible. These resistors are a good application for trimmed, thin film resistor packs that can be ratio-matched to 0.01% if needed. The resistance value of R7 is calculated from the expression:

$$7.2405 = (1 + 2(10 \text{ KW})/R7)$$

(10 KW/10 KW) with the result

$$R7 = 3.2049 \text{ KW}$$

The circuitry described provides a complete signal-conditioning solution for a 100Ω PRTD. Other resistive transducers can use the same circuitry by adjusting the current source and gain of the instrumentation amplifier.

For other types of RTDs, the component values can be adjusted to achieve the desired function.

For more information visit the [Amplifiers Featured Community](#)