

How to Meet the HDMI 5V Source Requirement

Application Note AN-1998

Kevin McCrory, Sales Engineer Larry Virgilio, Field Applications Engineer

Introduction

The mobile device industry has recognized multimedia content, and the ability to share that content, as a major focus to satisfy customer demand and drive growth. The ever-increasing popularity of websites such as YouTube, Facebook, and MySpace illustrate this demand. In January 2009 alone, YouTube users watched six billion videos. It is also estimated that 20 hours of new video are uploaded to YouTube every minute (*Reference 1*). This increasing desire for online interaction with friends and loved ones fundamentally drives demand for a personal device which is portable and sufficient at capturing and replaying multimedia.

At the same time, a revolution is happening in the home entertainment market. High-resolution digital content is becoming the norm and is driven through products like high-definition television programming, digital video recorders, BluRay DVDs, 1080p flat panel televisions, high-resolution personal video cameras, and 5.1 surround sound audio systems. In order to enable connectivity between these various units, high-definition multimedia interface (HDMI) has emerged as the standard for high-definition audio and video. In January 2009, HDMI Licensing LLC announced over 600 million HDMI-enabled devices are in existence worldwide. In-Stat estimates another 394 million HDMI devices will ship in 2009 (*Reference 2*).

Ubiquitous cameras, large displays, 3G connectivity, expanding memory, and powerful processors have made the latest generation of mobile products and handsets more than capable of capturing and storing multimedia content. The next step for the on-the-go user is to be able to easily share and review this content in a comfortable medium. The domination of HDMI in the home entertainment market offers a clear solution for bridging the gap to a user's mobile content. By implementing HDMI, a mobile device now offers the user seamless integration with virtually all new entertainment systems.

HDMI Compliance Requirements

Based on the requirements set forth in the HDMI Specification Version 1.3a, compliance requires each node sourcing a 5V power signal to be regulated and well protected. This 5V source must be current limited and also provide reverse current protection during many system scenarios (*Reference 3*).

Section 4.2.7 of Version 1.3a provides full detail of the regulation requirements. In summary,

A source shall:

- Provide a voltage between 4.8V and 5.3V
- Implement over-current protection of less than 0.5A
- Supply a minimum of 55 mA

A sink shall:

- Not draw more than 10 mA from the power signal, when powered on
- Assume any voltage within 4.7V and 5.3V indicates a source is connected

Section 4.2.11 of Version 1.3a outlines the protection needed on the 5V supply; namely,

- No damage to the HDMI source or sink can result from the shorting of any combination of signals on any connector. If two HDMI sources are connected together with a single cable, no damage can occur to either of the sources. If two HDMI sinks are connected together with a single cable, no damage can occur to either of the sinks.

The implication of Section 4.2.11 is that an ordinary 5V regulated supply cannot be used. It must apply protection so that if another source is applied to the pin, the reverse current will not damage any part of the circuit. In a mobile device, this applies when the device is operating and even when the device is powered down or without power at all (battery has been removed).

Regulation and Protection through Integrated Circuits

Fortunately, there are completely integrated circuits that can perform this type of protection while also supplying a regulated 5V. One example is National's PowerWise® LM2757 boost regulator.

The LM2757 is a constant-frequency, pre-regulated, switched-capacitor charge pump that operates at 1.25 MHz to produce a low-noise regulated output voltage. The device can provide up to 180 mA at 5V.

In order to meet HDMI protection standards, the LM2757 regulator presents high impedance at the V_{OUT} pin when shut down or with no power at the V_{IN} pin.

When the LM2757 regulator is operating and supplying 5V, several protection features may be implemented, depending on the fault condition. If the output is shorted to ground, current limit will allow no more than 250 mA to be sourced. If this short is sustained, the device will continue to source current until thermal shutdown is reached. If another HDMI source is applied to the output of the LM2757 regulator and that source voltage is below that of the LM2757, then the LM2757 device will regulate that voltage up to that of the LM2757. Only enough current will be sourced to regulate that voltage up to the LM2757. The LM2757 regulator does not

sink current; therefore, if another HDMI source is connected which has a higher voltage, the device will act as though no regulation is needed.

Figure 1 illustrates an example of how the LM2757 boost regulator can be implemented. The device is offered in a 1.2 mm x 1.6 mm x 0.4 mm package and requires only four small external capacitors. Therefore, with a total solution size of less than 12 mm², this sophisticated 5V supply can be implemented with minimal impact to the overall size of the end system.

Conclusion

On-the-go multimedia functionality is an exciting and in-demand future direction of mobile devices. HDMI is a logical way to implement connectivity of multimedia content to other nodes in the home and on the road. If HDMI is the mobile solution of choice, integrated circuits such as the LM2757 regulator make adoption easy and space efficient.

References

1. "YouTube," Wikipedia
2. "HDMI," Wikipedia
3. "High-Definition Multimedia Interface Specification Version 1.3a," Hitachi, Ltd., Matsushita Electric Industrial Co., Ltd., Philips Consumer Electronics, International B.V., Silicon Image, Inc., Sony Corporation, Thomson Inc., Toshiba Corporation, November 10, 2006.

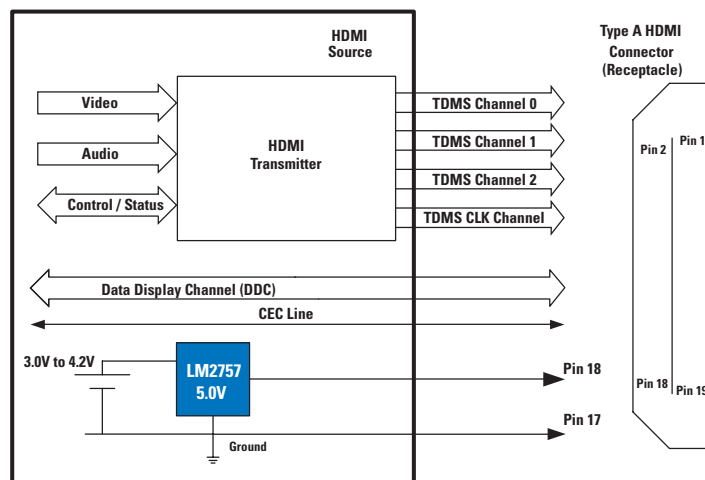

Figure 1. HDMI System Block Diagram

National Semiconductor
2900 Semiconductor Drive
Santa Clara, CA 95051
1 800 272 9959

Mailing Address:
PO Box 58090
Santa Clara, CA 95052

For Additional Design Information

national.com/edge

 National
Semiconductor