

TECHNOLOGY | edgeSM

Improving System Performance with a Semiconductor Temperature Sensor and Switch

Application Note AN-1984

Introduction

As electronic systems continue to include more features and higher performance in smaller packages, system heating issues are increasingly becoming a crucial design consideration. System overheating can reduce performance, damage components, or even be a safety concern. Two parameters often monitored to track and mitigate these system heating issues are continuous temperature measurement and over-temperature alarm signaling.

Continuous temperature measurement enables the processor to detect increasing or decreasing temperature trends and take compensating action based on the measured temperature. For example, a Power Amplifier (PA) can exhibit an increase in gain as it is subjected to increased temperatures. The increased gain causes the PA to use more power; this causes it to generate more heat which, in turn, causes more power and heat. This trend is called thermal runaway. In an application such as a wireless sensor network, excessive gain can cause the battery to be drained sooner than desired. By monitoring the temperature, the processor can adjust the gain of the amplifier, keeping power dissipation right where the designer wants it to be.

A binary over-temperature alarm signal is another key component of thermal management since it signals the processor when the system operating temperature exceeds a critical limit. One application example would be when the temperature in a system is about to exceed the maximum operating temperature of the components. In this case, the processor can disable the power from a supply to the components and prevent damage due to overheating.

System processors typically monitor temperature by converting a temperature-proportional voltage to a binary

code through an Analog-to-Digital Converter (ADC). The temperature signal, the analog voltage that varies as a function of temperature, is generated from a temperature sensor. This article compares the system design and performance advantages of sensing with National Semiconductor's LM57 CMOS integrated circuit sensor as compared to a thermal-resistor (thermistor) sensor circuit.

Discrete Thermistor Circuit

Discrete-component circuits for both continuous temperature measurement and over-temperature alarm indication have traditionally used a thermistor for a sensor element (*Figure 1*). The most commonly used thermistor is a negative-temperature-coefficient (NTC) thermistor; as temperature increases, the resistance of the NTC thermistor decreases. For a system processor to utilize the temperature information from a thermistor, the temperature-to-resistance parameter is generally converted to a temperature-to-voltage signal.

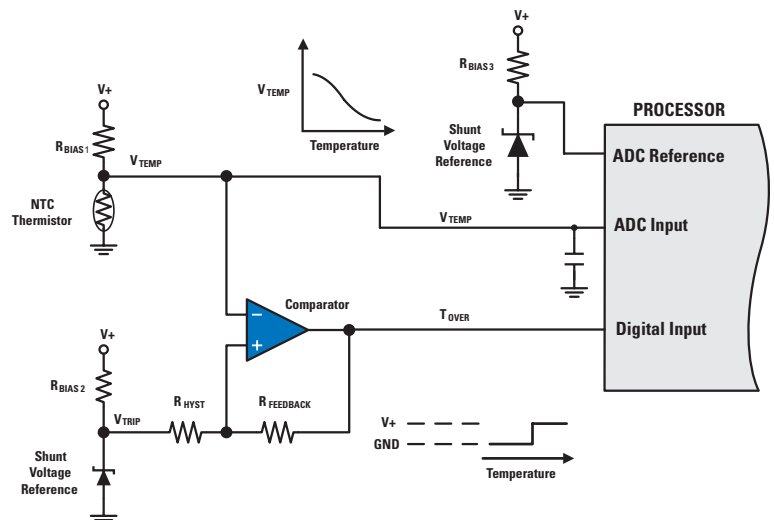

Figure 1: Classic Thermistor-based Discrete Temperature Sensor Circuit

The analog temperature signal is derived directly from the voltage divider, producing a voltage level that is an analog of the thermistor's temperature (V_{TEMP}). The R_{BIAS1} resistor is necessary to set the gain of the circuit and to keep the thermistor operating within its optimal power dissipation, which minimizes temperature-induced error in the resistance. The over-temperature alarm (T_{OVER}) is generated by connecting the output of the thermistor to the input of a comparator. A reference voltage is connected to the other input of the comparator in order to set the voltage (over-temperature level) at which the comparator output is to go active. A hysteresis feedback loop is included to keep the comparator from rapidly switching back and forth when V_{TEMP} is equal to the V_{REF} .

The discrete thermistor solution does have a number of design drawbacks such as the accumulated error of all the components, power consumption, linearity, quantization noise, operating temperature range, board area, and production cost. The LM57 integrated analog temperature sensor and temperature switch addresses these design drawbacks and improves the performance of the system.

The Integrated LM57 Circuit

National Semiconductor developed the LM57 integrated circuit to provide a complete temperature sensor and over-temperature alarm solution in one component. It integrates all the features of the discrete circuit shown in *Figure 1* plus it includes additional features – all while providing better performance specifications. The LM57 single-chip solution is illustrated in *Figure 2*. Since the whole sensor solution is integrated, fewer components are necessary and extra functions are included, like the active-low and active-high trip point output and an input pin that allows a system to test the LM57's functionality while still in the system (in situ). The temperature trip point (T_{TRIP}) is easily set by choosing the correlated values of the sense resistors, R_{SENSE1} and R_{SENSE2} .

Accuracy

One of the most important measurements in any temperature sensor circuit is the accuracy (or error) of the total circuit. When designing a discrete solution, the error from each component must be added to determine the worst-case total circuit error of the measurement. For example, the accuracy of the analog temperature output (V_{TEMP}) in the discrete thermistor circuit (*Figure 1*) will be affected by the sum of the accuracies of the thermistor and of resistor R_{BIAS1} . The accuracy of the T_{OVER} digital alarm will be affected not only by the accuracy of V_{TEMP} , but also the error inherent in the reference bias (R_{BIAS2}), the shunt reference, the comparator, the feedback resistor, and the hysteresis resistor. If this circuit were used to control, for example, a large building climate control system, these errors could mean motors and elements will be running when they don't need to be – resulting in excessive power usage by the system.

The LM57 does not induce these multiple sources of error since it is fully integrated (*Figure 3*) and is calibrated at the time of production. Thus the designer does not have to add up all of the sources of error due to the constituent components. The LM57 guaranteed maximum error of the V_{TEMP} analog output is $\pm 0.7^{\circ}\text{C}$ and the maximum error of the T_{OVER} alarm output is $\pm 1.5^{\circ}\text{C}$. These are worst-case limits that the system engineer can design to without calculating the sum of all the error sources in the circuit.

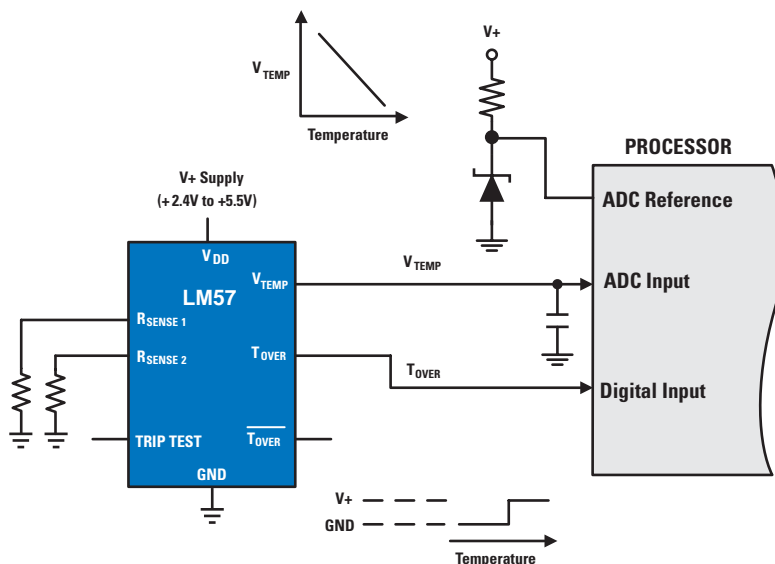

Figure 2: LM57 Integrated Circuit Application

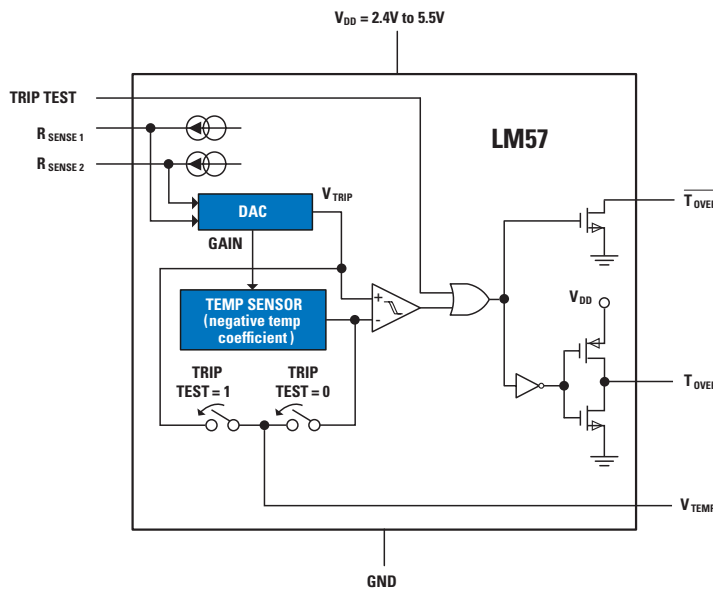

Figure 3: Functional Block Diagram of LM57 Integrated Analog Temperature Sensor and Temperature Switch

Supply Current

One of the biggest concerns for system designers today is system power consumption. The LM57 has extremely low power consumption compared to an NTC-based discrete circuit. *Figure 4* shows the typical current consumption of three circuits: LM57, a 100 k Ω NTC thermistor discrete circuit, and a 10 k Ω NTC thermistor discrete circuit.

When calculating the supply current of the discrete circuits, the sum of the supply currents for the thermistor, comparator, and two voltage references was calculated. Note that a very low-power comparator (LMV7271) and two low-power references (LM4128) were used in the calculations; these components contributed only 129 μ A of supply current for devices other than the NTC. The majority of the current consumption in this simulation is due to the NTC and its bias resistor. As temperature increases, the thermistor resistance decreases, causing much greater current draw for the circuit. In the case of the 10 k Ω thermistor circuit, the supply current reaches 437 μ A at 125°C.

By contrast, the LM57 consumes a mere 24 μ A of supply current over its full operating range of -50°C to 150°C. The integrated sensor uses a low-power CMOS band-gap sensor, which provides significant power savings over thermal-resistive circuits.

Quantization Noise

Obtaining maximum precision in a sensor measurement requires attention to quantization noise error, which is the error introduced by the conversion from the analog signal to binary data. As the analog signal is digitized, it is assigned a digital value that is the closest to the actual analog value being measured. The smallest increment of digital measurement, called a least-significant bit (LSB), is a voltage which is equal to that of the ADC reference divided by the number of codes that the ADC can count. For example, a 2.56V reference used on an 8-bit ADC would produce an LSB size of $2.56V \div 2^8 = 10$ mV. Any difference between the analog value being measured and the digitized value

will be an error in the conversion; this is called quantization noise or quantization error. For example, if you are trying to sample a 1.384V signal and it gets digitized to the nearest 10 mV value, say 1.380V, then a quantization noise value of 4 mV results on the sampled value. For a more thorough discussion of quantization noise, see “The ABCs of ADCs” on the national.com website (http://www.national.com/appinfo/adc/files/ABCs_of_ADCs.pdf).

So what does this noise mean in terms of temperature error? The answer depends on the gain of the sensor output. A higher gain magnitude from the sensor is less affected by noise than a lower gain – the higher the sensor gain, the less error from quantization noise. *Figure 5* compares the temperature measurement error that results from quantization noise between the LM57, a 100 k Ω NTC thermistor circuit, and a 10 k Ω NTC thermistor circuit. The analog output of the LM57 is very linear with a typical gain of -12.92 mV/°C when the trip temperature is set to 125°C (actually the LM57 has four possible gains, depending on the trip point value selected; 125°C is used in this example). This means that for every millivolt of noise, the effect on the temperature is $1/12.92 = 0.077$ degrees of temperature error.

The effect of noise is significantly worse in the 10 k Ω NTC circuit below -35°C and above 75°C. At the cold operating temperature limit for the thermistor of -40°C, the temperature error is 0.102°C of for every mV of noise. At the hot operating temperature limit of 125°C, the error is 0.265 °C/mV. The 100 k Ω NTC circuit is even more affected by noise. It has more error per mV of noise than the LM57 below -5°C and above 100°C. At the cold operating limit, it shows 0.436 °C/mV of error and at the hot limit it is 0.155 °C/mV.

When the analog output of the LM57 is set to its highest gain and is sampled by an ADC, the quantization error is much less in the cold and hot regions of the operating temperature than it is when sampling the discrete thermistor circuits.

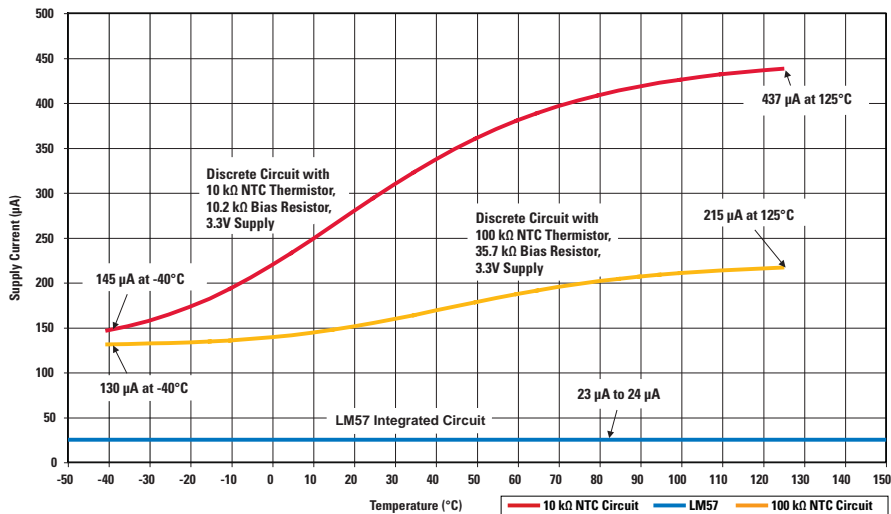

Figure 4: Comparison of Typical Supply Current Between the LM57 and Two NTC Thermistor-based Discrete Circuits

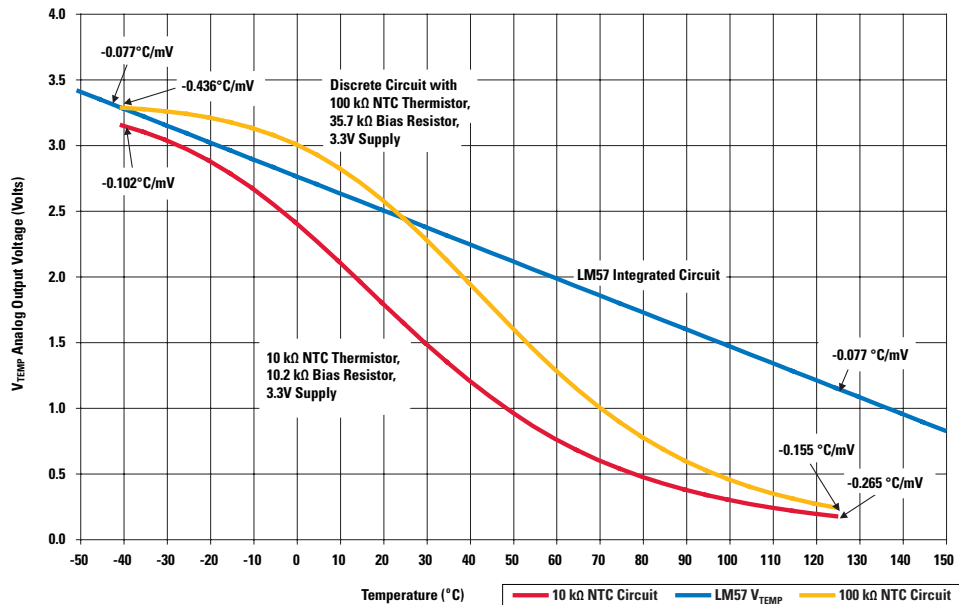

Figure 5: Comparison of Quantization Noise Sensitivity between LM57 and NTC Thermistor Discrete Circuits

Operating Temperature Range

Another benefit that the LM57 delivers over a thermistor is that it has a wider useful operating range. Referring to *Figure 5* again, the LM57 operates over the range of -50°C to 150°C . The NTC thermistors used in this comparison are rated from -40°C to 125°C which is a typical operating range for these components. Due to the flat gain, or low sensitivity, near the ends of the operating temperature, the useful range of the thermistors are more like -20°C to 100°C . With a linear output and strong performance specifications over its full -50°C to 150°C range, the LM57 enhances system performance over a much greater temperature range than an NTC does. For example, the LM57 delivers excellent accuracy, noise tolerance, and supply current at 140°C , a temperature that is beyond the rating of the NTC.

Design Time and Board Area

In today's ever-shorter product development cycles, the integration of the LM57 provides value by reducing design time. It drops into a circuit and connects to the processor or other load with negligible design optimization. There is no matching of components, sequential error budgets, etc.

The small size of the single package saves board area, production costs, and improves quality. With the multiple components in a discrete solution, board space is consumed because a minimum distance is required around each component. Each time a new component is added to the design, the cost of placing that component adds to the cost of the product. Each additional component adds one more device and two or more connections, each of which bring their own quality concerns.

Summary

The integrated LM57 analog temperature sensor and temperature switch incorporates all the features of a traditional temperature sensor and comparator circuit, plus adds features and has better performance than discrete solutions.

For further information on thermal management products, visit national.com/tempsensors.

National Semiconductor
2900 Semiconductor Drive
Santa Clara, CA 95051
1 800 272 9959

Mailing Address:
PO Box 58090
Santa Clara, CA 95052

For Additional Design Information

national.com/tempsensors

