

Class D Amplifier FAQ

By
John Guy
Applications Engineer
National Semiconductor Corp.

Purpose of this FAQ

This FAQ is intended to capture a variety of knowledge about the selection, application, and measurement of Class D amplifiers. The emphasis of this FAQ is towards Class D amplifiers in the 0.5W to 2W range intended for portable media devices such as mobile phones, portable DVD players, and portable navigation systems. However, the vast majority of this information can be applied to Class D amplifiers from milliwatts to kilowatts of output power.

What is a Class D amplifier?

A Class D amplifier uses pulse-width modulation circuitry to keep its output transistors operating either all the way on or all the way off. That is, at any time the instantaneous output voltage is either at one supply voltage or the other, ignoring a brief period of transition during the switching. Therefore, the output current is conducted from a device with no significant voltage drop. Ohm's law states that power is equal to voltage multiplied by current. A Class D amplifier keeps the voltage component of this equation near zero, removing most of the power dissipation from the output stage. Class D amplifiers have higher efficiency than all other topologies; they have typical efficiencies as high as 95%, although most are in the mid 80% range. Class D amplifiers switch at a frequency much higher than the audio band. Most Class D amplifiers switch from about 300kHz to 2MHz.

Why should I use Class D?

Because Class D amplifiers are very efficient, they provide the best use of the finite power available from a battery or other limited power source. Furthermore, this high efficiency eliminates heat-sinking requirements for most amplifiers below 10W output power. Class D amplifiers do not heat their neighboring components as much as other topologies, reducing the ambient temperature in the enclosure. Additionally, the thermal efficiency of Class D amplifiers allow them to use standard IC packages with no special consideration for thermal dissipation.

When should I not use Class D amplifiers?

The most important reason why Class D amplifiers are not used in all applications is that the switching of the outputs causes EMI. In most applications this EMI can be contained

such that the device meets EMI certification, but this is an additional concern causing some designers to avoid Class D amplifiers.

A secondary concern for Class D amplifiers is that their sound quality *in general* is not as good as Class AB and other topologies. While comparing the two topologies on paper can lead to this conclusion, in the final application it is often not an issue because the loudspeaker dominates the distortion of the system.

What is a half-bridge / single-ended Class D amplifier?

A half-bridge Class D amplifier has one output per channel. The loudspeaker connection for a half-bridge (also known as a single ended output amplifier) is between this single output and ground in a dual supply system. In a single supply system a large capacitor is used to block the $V_{CC}/2$ DC voltage from appearing across the loudspeaker load. This capacitor is usually several hundred microfarads or more, depending on the bass requirements of the system and the impedance of the loudspeaker.

The half-bridge amplifier is good for systems which already have a symmetrical dual supply voltage. The expense and size of the required DC blocking capacitor makes them not as desirable for single supply systems.

What is a full-bridge / differential Class D amplifier?

A full-bridge Class D amplifier has two outputs per channel. A full-bridge amplifier is also known as a Bridge-Tied-Load (BTL) amplifier or a differential output amplifier. The loudspeaker connection for a full-bridge Class D amplifier is between the two outputs in either a single or dual supply system. The Class D amplifier has a low output offset, eliminating the need for a DC blocking capacitor.

The full-bridge amplifier provides the smallest solution size in most systems, and is the most common Class D amplifier topology.

Is a Class D amplifier a “digital” amplifier?

In most situations a Class D amplifier is *not* a digital amplifier. This is intentional for a number of reasons. In a basic open-loop digital Class D amplifier the power supply rejection of the amplifier is essentially zero. In fact, the power supply magnitude can actually be used as a volume control. Another issue with a pure digital amplifier is mismatch in the output delay, transition time, and overshoot. Each of these adds up to create nonlinearity in the output, corresponding to harmonic distortion.

Fortunately, an analog approach mitigates these shortcomings. The vast majority of Class D amplifiers use global feedback and error correction in the analog domain. This provides THD+N in the range of 0.01%, and PSRR over 80dB is not uncommon.

Some Class D amplifiers are true digital amplifiers. Proprietary digital circuits compensate for the nonlinearity of the output limitations. True digital Class D amplifiers make up a very small proportion of available Class D amplifier ICs.

What are the advantages of half bridge versus full bridge Class D amplifiers?

A half-bridge Class D amplifier uses a smaller IC (silicon die) to get the same amount of power, and thus provides the lowest cost per watt when comparing the cost of the IC itself. The half-bridge device needs a DC blocking capacitor in single supply systems, often eliminating the entire cost advantage, plus adding a penalty for larger solution size.

In applications with a very large LED backlight supply, such as 24V, it can be cost effective to use half-bridge amplifiers driving 8 ohm loads to obtain 8W to 10W per channel of output.

What other classes of amplifiers are there?

The commonly accepted audio amplifier classes are

- ❑ Class A
- ❑ Class B
- ❑ Class AB
- ❑ Class D
- ❑ Class G
- ❑ Class H

A search of the web will provide the reader with the descriptions of these classes. Some IC manufactures have chosen to add “new” classes to describe their particular variant of Class D. A discerning engineer should look at the merits of the available devices and not be swayed by the latest marketing descriptions.

What about Class D headphone amplifiers?

Class D headphone amplifiers have been available for some years. Their application can be problematic due to the nature of the headphone itself. Obtaining low EMI performance from a Class D amplifier requires the engineer to have control over the wiring length, the wiring type, and the load impedance of the loudspeaker. When the user connects an arbitrary headphone to a standard headphone jack, all this control is unavailable. Indeed, the headphone wire itself is such a good antenna many portable devices use it as the FM receiving antenna.

In self-powered headsets this is not a problem. Many Bluetooth headsets have full-bridge Class D amplifiers to provide the best possible battery life. In this system the wires are very short and the load impedance is known.

Can a Class D amplifier operate from a lithium battery?

Class D amplifiers for portable devices are typically specified for operation from below 3V to above 4.2V, ideal for use with lithium ion or lithium polymer batteries. Across this voltage range the available power changes with battery voltage. For example, into an 8Ω load, 3V gives about 500mW, and 4.2V gives about 1.1W. Actual performance depends on the Class D amplifier.

How do I get constant output power over a wide supply range?

The high efficiency of Class D amplifiers makes them ideal for operation from boosted supplies. Some applications need 1W output power into 8Ω, regardless of battery voltage. In these systems, operating the Class D amplifier from a 5V boosted supply provides this performance.

Some Class D amplifiers have a boost converter built in, such as the [LM48510](#). This provides a dedicated switched-mode power supply to provide up to 5.5V for the Class D amplifier. An added benefit of this approach is the boosted supply can also be used for LED flash or lighting.

Class D Amplifier Filters

What is filterless Class D?

A filterless Class D amplifier has its output modulation adapted such that it can be connected directly to a loudspeaker without a filter. A filterless Class D amplifier can be used provided the wire length to the loudspeaker is less than about 10cm in many applications.

Using a Class D amplifier, which is not filterless without a filter, is not advised. The PWM waveform will cause high I^2R losses in the loudspeaker's voice coil, reducing battery life and possibly damaging the loudspeaker.

Why is there a filter on my filterless Class D amplifier?

Many filterless Class D amplifiers, such as the [LM4675](#) include a filter on their demonstration board. This filter is there to allow the user to measure the performance of the Class D amplifier with typical oscilloscopes and audio analyzers. The PWM waveform is larger than the audio signal itself, and overloads the inputs of most test equipment. The presence of a filter allows system verification using standard test equipment.

Do I need a filter on my Class D amplifier?

In applications with short lead lengths to the loudspeaker the answer is usually no. Some Class D amplifiers use spread-spectrum clocking to reduce the apparent RF energy in the output. Edge-rate limitation circuitry reduces the actual RF energy in the output. Combining spread-spectrum with edge-rate limiting, such as found on the [LM48310](#), provides the best chance of achieving EMI certification with no output filter.

How do I design a filter for a Class D amplifier?

A low-pass filter for a Class D amplifier is designed with the same equations and software as a loudspeaker crossover. In most applications, a second-order Butterworth transfer function is the best combination of performance, sensitivity, and cost. For a single-ended amplifier, the equations are:

$$L = (0.225 * R_L) / f_C$$

$$C = 0.113 / (R_L * f_c)$$

where R_L is the impedance of the loudspeaker, f_c is the desired cutoff frequency, and L and C are the inductor and capacitor values for the filter. For example, with a load impedance of 8Ω , and a desired cutoff frequency of 30kHz , the inductor value is $60\mu\text{H}$ and the capacitor value is $0.47\mu\text{F}$. Unfortunately, $60\mu\text{H}$ is a non standard value, so we increase its value up to the standard value of $68\mu\text{H}$. Solving back through the inductor equation gives a new cutoff frequency of 26.5kHz , which we solve for a new capacitor value of $0.53\mu\text{F}$, which can be approximated with a $0.47\mu\text{F}$ capacitor in parallel with 6800pF capacitor. The schematic for this is shown in Figure 1.

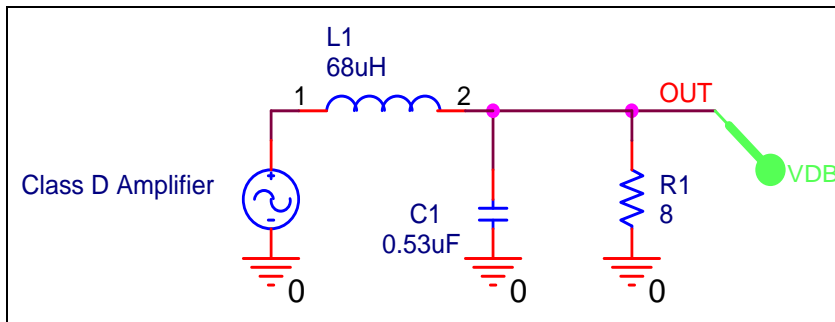

Figure 1. An output filter for a single-ended Class D amplifier.

For a full-bridge Class D amplifier the equations are modified as follows:

$$L1 = L2 = (0.113 * R_L) / f_c$$

$$C_{TOT} = 0.225 / (R_L * f_c)$$

where $L1$ and $L2$ are the two required inductors, and C_{TOT} is the total load capacitance. The load capacitance of a full-bridge Class D amplifier filter is usually split between three capacitors per the following equation:

$$C_{TOT} = C_{S1} + C_{S2} + (2 * C_{D1})$$

where C_{S1} and C_{S2} are shunt capacitors to ground, and C_{D1} is a differential capacitor. For example, with a load impedance of 8Ω , and a desired cutoff frequency of 30kHz , the inductor value is $30\mu\text{H}$ and the capacitor value is $0.934\mu\text{F}$. Unfortunately, $30\mu\text{H}$ is a non standard value, so we increase its value up to the standard value of $33\mu\text{H}$. Solving back through the inductor equation gives a new cutoff frequency of 27.4kHz , which we solve for a new capacitor value of $1.03\mu\text{F}$. Selecting $0.47\mu\text{F}$ for C_{D1} and $0.047\mu\text{F}$ for C_{S1} and C_{S2} satisfies the equation for C_{TOT} . The schematic for this is shown in Figure 2.

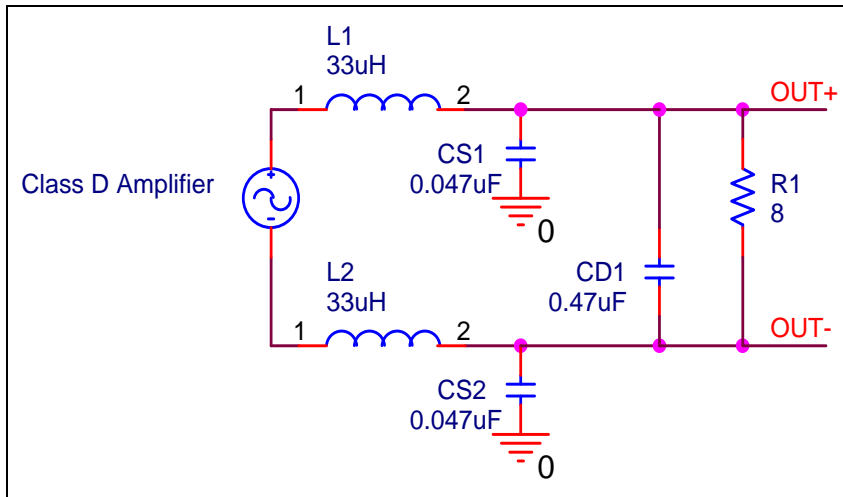

Figure 2. A full-bridge Class D amplifier filter.

A big advantage of splitting the filter capacitance this way is that it has good EMI and good audio performance. The larger cap C_{D1} provides the majority of the audio band filtering. The lower value of $CS1$ and $CS2$ make them more appropriate for reducing the higher frequencies associated with EMI testing.

What is a Zobel?

A Zobel is an impedance matching circuit often used with loudspeakers. A Zobel circuit is also known as a Boucherot cell or somewhat incorrectly as an RC snubber. The nominal impedance of a loudspeaker is not constant, and rises significantly at the upper end of the audio band. In order for a Class D amplifier filter to work as designed, this rising impedance needs to be included in the design. The easiest way to compensate for this is a Zobel, a simple series resistor and capacitor across the loudspeaker terminals. Although the selection of Zobel components depends on a number of factors, the following equations are a good starting point:

$$R_Z = R_L$$

$$C_Z = 1 / (2 * \text{Pi} * f_C * R_L)$$

Where R_Z is the Zobel resistance and C_Z is the Zobel capacitance, R_L is the impedance of the loudspeaker, f_C is the desired cutoff frequency. For our 27.4kHz full-bridge example, this works out to a C_Z of 0.73 μ F. In most applications, either a 0.47 μ F or 1 μ F capacitor can be used as this is not a very sensitive value. The schematic for this Zobel is shown in Figure 3.

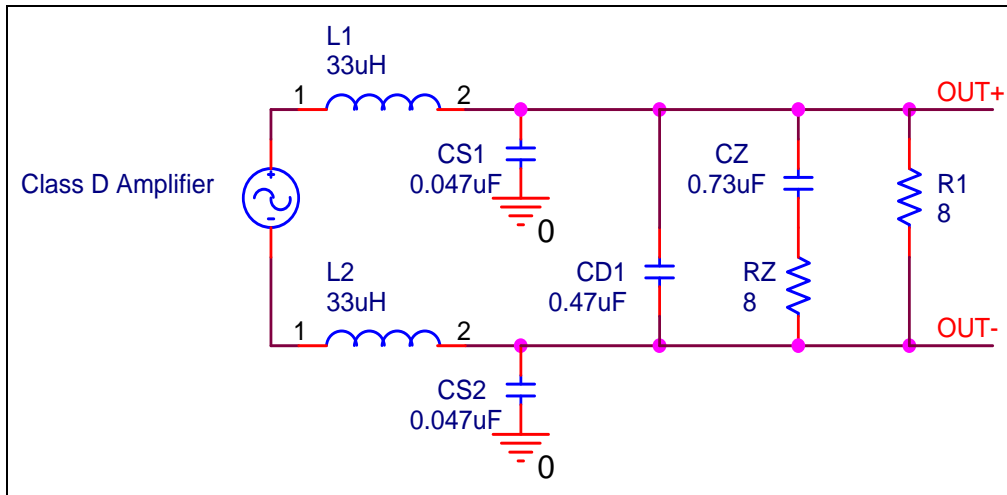

Figure 3. A Zobel circuit normalizes the rising impedance of the loudspeaker

Can I connect shunt capacitors to a Class D amplifier outputs to reduce EMI?

Sometimes people consider adding shunt capacitors to Class D amplifier outputs in an attempt to control EMI. This is shown in **Figure 4**. This should *almost never be done* due to the following potential problems:

- This can damage the Class D amplifier due to over current
- Useable output power is reduced
- THD+N is increased
- Class D efficiency is reduced
- EMI can get worse due to larger current transients

If a simple filter is needed, consider a ferrite bead in series before the shunt capacitors. See next topic.

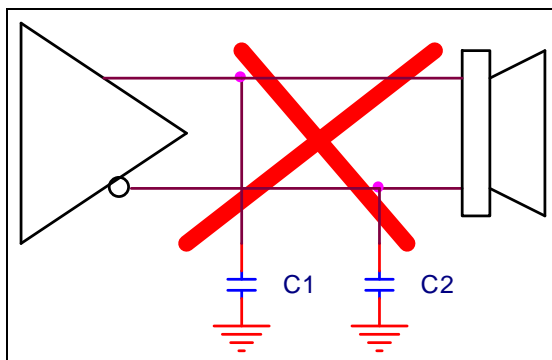

Figure 4. Do not connect shunt capacitors directly to Class D outputs.

Can I use a ferrite bead instead of an LC filter?

In many applications a Class D amplifier can be used with ferrite beads for filtering in conjunction with either shunt or differential load capacitance. A potential issue is that

ferrite beads appear as almost a short circuit at the switching frequency, their impedance typically begins to rise above 1MHz, with peak impedance near 100MHz. Because the impedance is low at the Class D amplifier's switching frequency, ferrite beads can increase the peak current during output transitions, exacerbating the EMI performance instead of improving it. Ferrite bead filters for Class D amplifiers are derived empirically while measuring the radiated emissions. In general, a 100Ω or higher ferrite bead rated for the peak load of the audio signal into the load impedance is a good starting point. For example, if the Class D amplifier operates from 5V into a 4Ω load, a ferrite bead with at least 1.25A peak current capability should be selected. The ferrite bead is often loaded with a pair of shunt capacitors to ground. Again, the value for these capacitors is often determined empirically, but 100pF is a good starting point. A schematic of a ferrite bead filter for use with a Class D amplifier is shown in Figure 5.

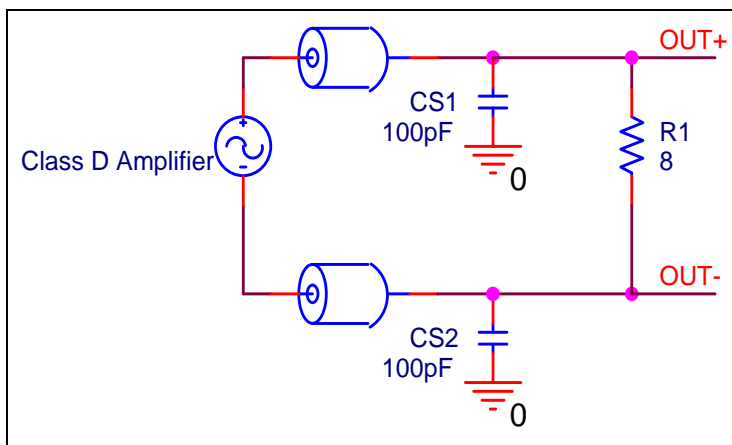

Figure 5. A Class D amplifier with a ferrite bead filter.

Can I use a dual inductor for a Class D filter?

A dual inductor has a pair of closely coupled windings on the same core. Dual winding inductors should only be used on Class D amplifiers with no special output modulation. In other words, only the tradition “textbook” Class D modulation is acceptable, where the two full-bridge outputs are 180° out of phase when there is no audio signal present. Any Class D amplifier advertised as “filterless” should not be used with a dual winding inductor.

There are some dual inductors specifically intended for use with a Class D amplifier, including devices from these manufacturers:

- ❑ [Sagami](#)
- ❑ [Korea Coil Engineering](#)
- ❑ [FDK](#)
- ❑ [Toko](#)

These application specific dual winding feature a lower mutual coupling of the two windings.

Can I use a common-mode choke for a Class D filter?

Some Class D amplifier modulation schemes allow the use of a common mode choke. A common mode choke presents a low impedance path to a differential signal and a high-impedance path to any common mode signal. Used in conjunction with a small capacitive load a common mode choke is more cost effective than inductors, but more costly than plain ferrite beads. Proper operation of a common mode choke with a Class D amplifier should be observed. The main parameter to verify is EMI, but also inspect quiescent current and THD+N as a function of output power. A Class D amplifier not compatible with a common mode choke will see degradation in performance for quiescent current and/or THD+N.

Should I use a differential capacitor or single-ended connection on a Class D filter?

Many existing Class D amplifiers use a single differential capacitor, while others only use a pair of shunt capacitors. In most cases, a single differential capacitor will often provide the best audio performance, while dual shunt capacitors offer the best EMI performance. The best solution is to use both differential and shunt capacitors, with the differential capacitance being the largest value, and the shunts being lower. In general, lower value capacitors perform better at higher frequencies.

Test and Measurement Issues

Why do I not see a sine wave on my oscilloscope?

A common customer complaint with Class D amplifiers is their inspection with common oscilloscopes. An engineer accustomed to see a sine wave on the output may think their amplifier is oscillating. Indeed, the amplifier is oscillating, that is by design. The addition of a 1k series resistor with a 4700pF capacitor shunt to ground will often suppress the switching frequency sufficiently to see the audio signal on an oscilloscope. If more accurate measurements are desired an active filter or a higher-order LC ladder filter should be used.

How do I measure a Class D amplifier?

The high switching frequency PWM output of a Class D amplifier overloads the inputs of most audio analyzers. Specialized filters, such as an Audio Precision [AUX-0025](#) provide a specialized filter to eliminate out of band energy. Barring that, a balanced 5th order filter should be constructed with a low distortion op amp, such as the [LME49740](#) to ensure accurate readings. An example circuit is shown in Figure 6. This circuit is a 5th order Butterworth, with differential front end and a single ended output. The circuit has unity gain, and can operate at up to 34V total supply. The cutoff frequency is 24kHz, and the circuit has a theoretical 108dB rejection of 300kHz, although actual performance will be less due to component mismatch.

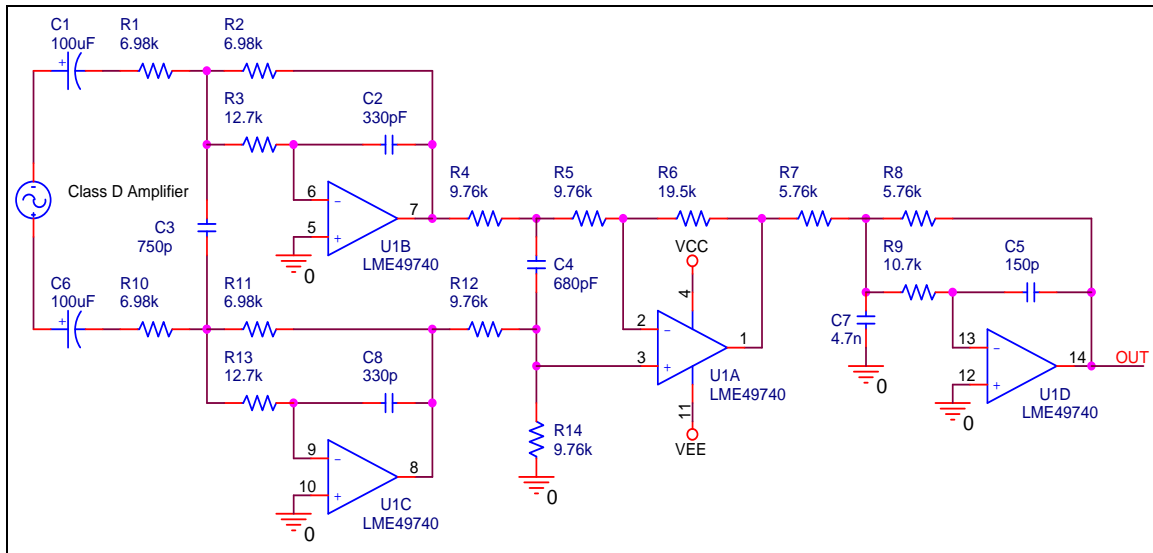

Figure 6. A 5th order Class D measurement filter

Can I use an 8Ω or 4Ω resistor as a test load?

Class D amplifiers should be tested with a load which represents an actual loudspeaker and not a simple resistor. If a simple resistor is used, the efficiency will be significantly worse than the actual performance. In most situations, add a 68μH inductor in series with an 8Ω resistor, and a 33μH inductor in series with a 4Ω load.

PCB Layout and Component Issues

Is PCB layout important on Class D amplifiers?

PCB layout is very important to Class D amplifiers to obtain the best SNR, best thermal efficiency, and the lowest EMI. Any designer new to this field should examine proven designs to ascertain best practices, as well as study of available literature.

How should I ground a Class D amplifier?

The proper technique for grounding Class D amplifiers is a subject of much debate. Some engineers use a star ground approach, where the individual grounds converge at a single point, often the analog or power ground of the Class D amplifier. While this is easy enough on a demonstration board with a single IC, it becomes problematic when there are multiple mixed signal ICs in the system. No one of these ICs can be the star ground, so another approach must be taken. Based on experiments comparing a star layout to a single continuous ground plane, the single ground plane approach showed marked improvement in not only the EMI, but also peak output power and lower THD+N. In this example the single ground plane was poured copper on both the top and the bottom of a two layer PCB. Every IC ground pin and the ground connection of every bypass capacitor uses at least one dedicated via to the two ground planes. Furthermore, in open areas of the PCB vias are placed from the top to the bottom ground plane. A via within every 2cm is a good idea, more if space is available.

With this single ground approach component placement is very important. The high frequency currents will take the path of least resistance, which is a straight line if one is available. Therefore, the PCB designer should attempt to place the components so that the current does indeed flow along this desired path, and yet does not cross other paths, such as sensitive analog inputs. The ability to do this well is an art. Again, the study of systems which have passed EMI certification are an excellent method for learning good layout techniques.

Is proper grounding of Class D amplifiers important?

Grounding is very important to Class D amplifiers to obtain the best SNR, best thermal efficiency, and the lowest EMI. Any designer new to this field should examine proven designs to ascertain best practices, as well as study of available literature.

Should I use two mono Class D amplifiers or one stereo device?

As previously mentioned, the Achilles heel of Class D amplifiers is their EMI. One possible approach to consider is the use of two mono amplifiers instead of a single stereo device. This way the leads from each Class D amplifier to its respective loudspeaker are minimized, reducing the radiation area. This is more beneficial in systems the size of notebooks than a mobile handset. If using multiple Class D amplifiers in a system, the devices should be driven with a common clock sync signal to ensure no beat frequencies are developed.

Which capacitors are best for Class D amplifier supply bypassing?

Ceramic chip capacitors are the best choice for power supply bypass on Class D amplifiers. Their low ESR and excellent high frequency characteristics improve audio performance and help lower EMI. If the Class D amplifier is located far from the power supply, some additional bulk capacitance should be included. The most cost effective for this is low ESR aluminum electrolytic capacitors, although general-purpose aluminum electrolytic capacitors are often used.

Some engineers will use multiple bypass capacitors to help with EMI. Located closest to the power supply pin is a small, 0.1 μ F or smaller, bypass capacitor, with a larger value, such as 1 μ F or greater located next down the line. General practice is to make these two capacitors at least ten times different in value to avoid a resonance band.

What can I do to help ensure regulatory certification for EMI?

Meeting regulatory testing limits for radiated emissions requires the designer to use a high quality, low EMI Class D amplifier in conjunction with proper grounding and bypass. Furthermore, some output filtering may be required depending on the length of the loudspeaker leads as well as the particular frequency band of concern for the final application.

How do I connect a single-ended audio source to a differential Class D input?

Many Class D amplifiers have differential inputs to reduce unwanted noise pickup. If a single ended source is used, a pseudo differential approach is best. Route the audio source's output and its output reference voltage as a differential pair to the Class D amplifier's differential inputs. Figure 7 has an example of this circuit.

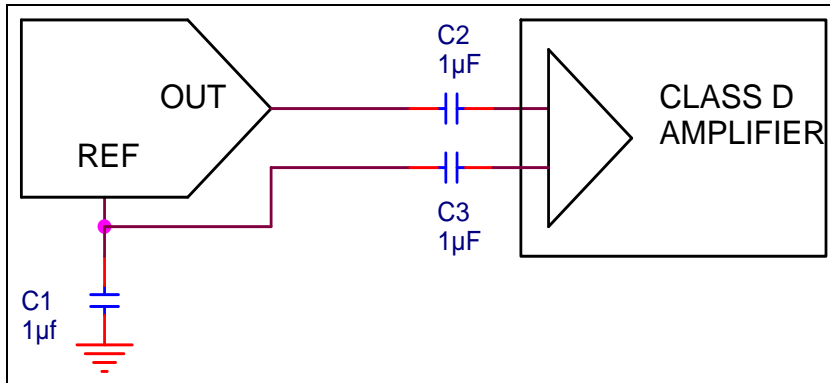

Figure 7. Circuit connects single-ended source to differential input Class D amplifier.

How do I connect a differential audio source to a single-ended Class D input?

If a differential source is connected to a single-ended input Class D amplifier, the easiest approach is to simply use one of the outputs and leave the other connected. Alternatively, a differential op amp can be added at the front of the Class D amplifier.

Revision History

0 – August 2008 – Initiate

1 – April 2009 – Added warning against using output shunt capacitors

An older version of this document was originally published in Audio Designline:

<http://www.audiodesignline.com/howto/212000761>