



Optimizing Portable Applications with D/A Converters

By Chuck Sins, Applications Engineer

Designers of portable electronic devices have several methods available for using general-purpose Digital-to-Analog Converters (DACs) to digitally adjust voltages and enhance the performance of portable devices.

DACs are most easily understood by examining a simplified DAC block diagram. As shown in *Figure 1*, the architecture of a one-channel DAC consists of a resistor array (each of equal value R) followed by a rail-to-rail voltage output amplifier. The voltage applied to the reference pin is the voltage at the top of the resistor array and a switch is connected between each pair of resistors and one to ground. The voltage is tapped off by closing one of the switches and connecting this point on the array to the amplifier. The resistor array and output amplifier consume very little power and emit no switching noise since the DAC is static once the specified resistor tap has been connected to the amplifier. In addition, multi-channel DACs packaged in a 3 mm by 3 mm Leadless Leadframe Package (LLP[®]) occupy very little board space in portable applications. An alternative to using a DAC is a resistive trim potentiometer. However, these devices are large in size, suffer from mechanical wear, and are not digitally controllable.

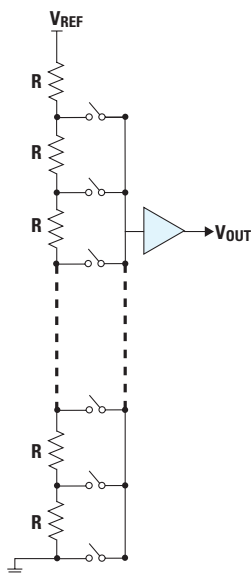

Figure 1. 1-Channel DAC Architecture

Over the last couple of years, the audio capability and LCD display quality of cell phones have improved tremendously, while the size and cost of the phones have gone down. Most phones today have a headphone jack, an earpiece, and a built in loudspeaker. All three of these audio outputs require some type of volume control. One way a DAC can provide volume control is when it is used in conjunction with an audio amplifier that has a built-in DC volume control. A micro-controller that receives input from soft keys on the display or push buttons on the case causes the DAC's output voltage to step up or down (*Figure 2*). Another way to control volume is to use a DAC as a single quadrant multiplier. This configuration consists of an amplifier gain stage that feeds the amplified audio input into the reference pin of the DAC (*Figure 3*). The Serial Peripheral Interface (SPI) of the DAC is used to digitally attenuate the amplified audio input anywhere from full scale (0 dB) to zero volts. This is accomplished without adding any noticeable level of noise or distortion to the audio signal.

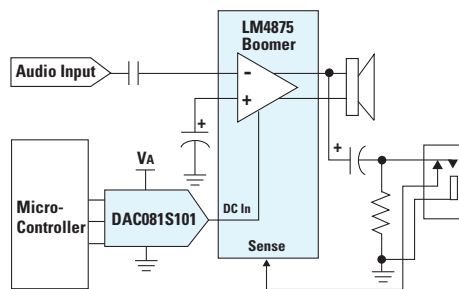

Figure 2. DC-Control of an Audio Amplifier

NEXT ISSUE:
Closed-Loop Bandwidth Accuracy

Featured Products

1-Channel, Pin- and Function-Compatible DACs Across Resolutions

The 1-channel, pin- and function-compatible 8-, 10-, and 12-bit DACs each provide rail-to-rail output swing and input clock rates of 30 MHz over the entire supply range of 2.7V to 5.25V. The reference for each is derived from the power supply, resulting in the widest possible dynamic output range. A power-down feature reduces power consumption to less than 0.2 μ W, which is especially important for portable, battery-powered applications.

The on-chip output amplifier allows rail-to-rail output swing and the three-wire serial interface operates at clock rates up to 30 MHz over the specified supply voltage range and is compatible with standard SPI™, QSPI, MICROWIRE, and DSP interfaces. The supply voltage serves as its voltage reference, providing the widest possible output dynamic range.

Features

- Settling time: 10 μ s
- Guaranteed monotonicity
- Low-power operation
- Rail-to-rail voltage output
- Power-on reset to zero volts output
- SYNC interrupt facility
- Wide power supply range: 2.7V to 5.5V
- Power down feature



Operating over the extended industrial temperature range of -40°C to +105°C, these DACs are ideal for battery-powered instruments, digital gain and offset adjustment, programmable voltage and current sources, and programmable attenuators. The DAC121S101, DAC101S101, and DAC081S101 are available in TSOT-6 and MSOP-8 packaging.

For FREE samples, datasheets, and more, visit
www.national.com/pf/DA/DAC121S101.html
www.national.com/pf/DA/DAC101S101.html
www.national.com/pf/DA/DAC081S101.html

Ultra Low-Power, 2-Channel, 8-/10-/12-Bit DACs

These general purpose DACs are full-featured and can operate from a single 2.7V to 5.5V supply and use 210 μ A at 3V and 320 μ A at 5V. The on-chip output amplifier allows rail-to-rail output swing and the three-wire serial interface operates at clock rates up to 40 MHz over the entire supply voltage range.



Features

- INL (max)
 - ± 0.5 LSB (DAC082S085)
 - ± 2 LSB (DAC102S085)
 - ± 8 LSB (DAC122S085)
- DNL (max)
 - +0.18 / -0.13 LSB (DAC082S085)
 - +0.35 / -0.25 LSB (DAC102S085)
 - +0.7 / -0.5 LSB (DAC122S085)
- Settling time (max)
 - 4.5 μ s (DAC082S085)
 - 6 μ s (DAC102S085)
 - 8.5 μ s (DAC122S085)
- Zero code error: +15 mV (max)
- Full-scale error: -0/75% FS (max)
- Wide power supply range: 2.7V to 5.5V

The 2-channel, 8-/10-/12-bit DACs are ideal for use in battery-powered instruments, digital gain and offset adjustments, programmable voltage and current sources, and programmable attenuators. The DAC082S085, DAC102S085, and DAC122S085 are available in MSOP-10 and LLP-10 packaging.

For FREE samples, datasheets, and more, visit
www.national.com/pf/DA/DAC082S085.html
www.national.com/pf/DA/DAC102S085.html
www.national.com/pf/DA/DAC122S085.html

Optimizing Portable Applications with DACs

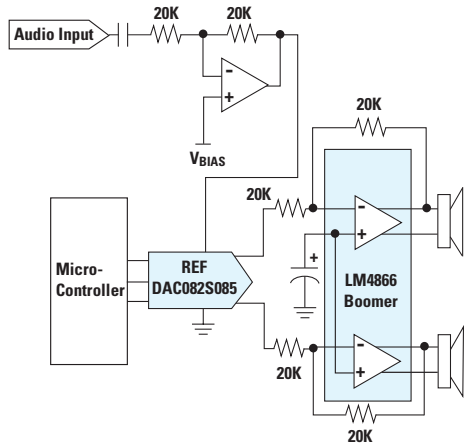

Figure 3. Single Quadrant Multiplying DAC

Many microprocessors can operate at a lower supply voltage to save power, and then operate at a higher supply voltage to increase their processing speed. Switching between these modes requires adjusting the output voltage of a DC-to-DC converter. Similar to microprocessors, LCD displays utilize DACs to control their contrast ratio. As the temperature of the display changes, the voltage applied to the display by the DC-to-DC converter must be adjusted to maintain the proper contrast ratio (*Figure 4*). Since neither of these applications require high speed adjustments, general purpose DACs are the ideal solution for digitally optimizing their performance.

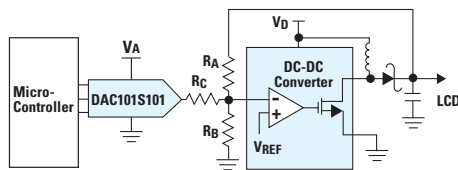

Figure 4. DAC Controlling a DC-DC Converter

Portable devices that utilize sensors can also be enhanced with the use of general purpose DACs. *Figure 5* illustrates a pressure sensor that is amplified and then monitored by a general purpose Analog-to-Digital Converter (ADC). Since the output of the amplifier stage has a large voltage range, the ADC requires a reference voltage equal or greater to the largest possible output voltage. While this is fine for measuring the sensor's output when it is at its maximum voltage, it is less than ideal for measuring the sensor's minimum output voltage. If a DAC was utilized as the reference voltage, the DAC could be digitally adjusted

based on the input to the ADC. This technique maximizes the accuracy of the ADC and allows the full range of codes to be utilized. The alternative solution is to use a more expensive ADC with a higher resolution in order to improve the system's accuracy. As a result, using a DAC in the circuit reduces the overall system cost while still providing the required accuracy.

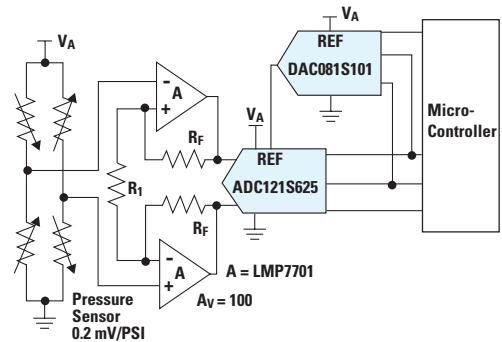

Figure 5. Pressure Sensor Monitoring by an ADC

A similar application with a DAC enhancing system performance is a system that requires calibration for higher conversion accuracy. For example, a humidity sensor can be calibrated to a known ADC output code with the circuit in *Figure 6*. The sensor's output is applied to the negative input of the op-amp while a DAC output is connected to the positive terminal. The desired output code of the ADC can be achieved by digitally adjusting the DAC output voltage to the appropriate level. Higher resolution DACs deliver higher precision in the output reading.

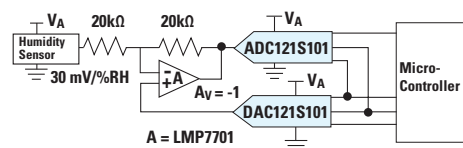

Figure 6. Humidity Sensor Application

In all of these examples, general purpose DACs optimized a product's performance by digitally adjusting a voltage in the circuit without impacting the product's size, cost, or power consumption. ■

View over 50 design seminars by industry experts at www.national.com/onlineseminars

Featured Products

Precision, CMOS Input, RRIO Amps

The LMP7701/02/04 are single, dual, and quad low offset voltage, rail-to-rail input and output precision amplifiers with CMOS input stage and wide supply voltage range. The rail-to-rail input stage significantly reduces the CMRR glitch commonly associated with rail-to-rail input amplifiers.



Features

- Input offset voltage (max)
 - $\pm 200 \mu\text{V}$ (LMP7701)
 - $\pm 220 \mu\text{V}$ (LMP7702/04)
- Input bias current: $\pm 200 \text{ fA}$
- Input voltage noise: $9 \text{ nV}/\sqrt{\text{Hz}}$
- 130 dB CMRR
- 130 dB open loop gain
- 2.5 MHz unity gain bandwidth
- Supply current
 - $715 \mu\text{A}$ (LMP7701)
 - 1.5 mA (LMP7702)
 - 2.9 mA (LMP7704)
- Supply voltage range: 2.7V to 12V

The LMP7701/02/04 are ideal for high impedance sensor interfaces, battery-powered instrumentation, high gain amplifiers, DAC buffers, instrumentation amplifiers, and active filters. The LMP7701 is available in SOT23-5 packaging, the LMP7702 is available in MSOP-8 packaging, and the LMP7704 is available in TSSOP-14 packaging.

For FREE samples, datasheets, and more, visit
www.national.com/pf/LM/LMP7701.html
www.national.com/pf/LM/LMP7702.html
www.national.com/pf/LM/LMP7704.html



Ultra Low-Power, 4-Channel, 8-/10-/12-Bit DACs

These 4-channel, 8-/10-/12-bit DACs are full-featured and can operate from a single 2.7V to 5.5V supply and use $360 \mu\text{A}$ at 3V and $480 \mu\text{A}$ at 5V. The on-chip output amplifier allows rail-to-rail output swing and the three-wire serial interface operates at clock rates up to 40 MHz over the entire supply voltage range.

The reference serves all four channels and can vary in voltage between 1V and V_A , providing the widest possible output dynamic range. A power-down feature reduces power consumption to less than a microWatt with three different termination options.

Features

- INL (max)
 - $\pm 0.5 \text{ LSB}$ (DAC084S085)
 - $\pm 2 \text{ LSB}$ (DAC104S085)
 - $\pm 8 \text{ LSB}$ (DAC124S085)
- DNL (max)
 - $+0.18 / -0.13 \text{ LSB}$ (DAC084S085)
 - $+0.35 / -0.25 \text{ LSB}$ (DAC104S085)
 - $+0.7 / -0.5 \text{ LSB}$ (DAC124S085)
- Settling time (max)
 - $3 \mu\text{s}$ (DAC084S085)
 - $4.5 \mu\text{s}$ (DAC104S085)
 - $6 \mu\text{s}$ (DAC124S085)
- Zero code error: $+15 \text{ mV}$ (max)
- Full-scale error: $-0/75\% \text{ FS}$ (max)
- Wide power supply range: 2.7V to 5.5V

The 4-channel, 8-/10-/12-bit DACs are ideal for use in battery-powered instruments, digital gain and offset adjustments, programmable voltage and current sources, and programmable attenuators. These DACs are available in MSOP-10 and LLP-10 packaging.

For FREE samples, datasheets, and more, visit
www.national.com/pf/DA/DAC084S085.html
www.national.com/pf/DA/DAC104S085.html
www.national.com/pf/DA/DAC124S085.html