



## High-Performance Analog Front Ends

by Ian King, Senior System Engineer

### High-Speed Signals

High-speed conversion systems, especially in the telecommunications field, allow the input to the ADC to be AC-coupled either through a transformer, a capacitor, or a combination of both. For the test and measurement industry however, the front-end design is not as simple because this application area often requires the input signal to be DC-coupled as well as provide the capability for AC-coupling. The design of an active front end that delivers good pulse response and low distortion from DC up to frequencies of 500 MHz (and beyond) is challenging. This issue of the Analog Edge<sup>SM</sup> will provide a few design ideas and suggestions for an analog front end for use with high-performance ADCs suitable for high-speed data capture.

The preferred method of interfacing high-frequency analog signals to the input of an ADC is through the use of differential amplifiers. Therefore, the first component to be selected should be a differential output operational amplifier. When choosing such a device, there are two main considerations: the gain bandwidth product and the ability to set the common-mode output voltage of the op amp from an external voltage. This is because it is very important that the signal amplifier driving the ADC's inputs has its common mode output voltage ( $V_{CMO}$ ) set within the optimum range for the ADC. If this condition is not met, the ADC's performance will rapidly degrade as the disparity between the amplifier's  $V_{CMO}$  and the ADC's optimum input common mode voltage increase.

The main disadvantage of wideband differential op amps is that they usually have limited gain and may also have their gain level preset internally. Depending on the application, it may be necessary to add a pre-amplifier to the design to meet the necessary gain requirement.

For the pre-amplifier, a very wideband op amp should be used in order to meet the desired input frequency of the ADC. For systems which sample up to 1 GSPS, this equates to an input bandwidth requirement of 500 MHz for over sampling systems.

Small Signal Non-Inverting Frequency Response

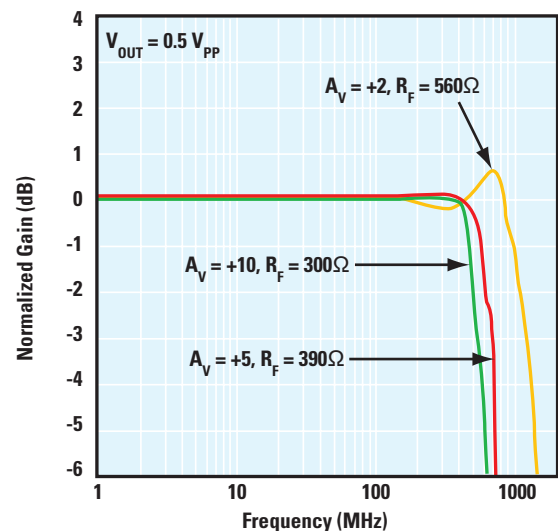

Figure 1. LMH6703 Frequency Response

For an operational amplifier to operate with significant gain ( $A_V=10$  for example) and maintain such a wide bandwidth, equates to a 5 GHz Gain Bandwidth (GBW) product. Most voltage feedback amplifiers will not be able to meet this specification due to the direct tradeoff between frequency response and gain inherent in this architecture. Current feedback amplifiers however, enjoy a much better relationship between these parameters because the performance is generally dictated by the value of the feedback resistor within the op-amp circuit. An op amp that is ideal for operating at high bandwidths with gain settings between 1 and 10 is the LMH6703. This device can be used with the selected differential amplifier to provide any extra gain requirements in high bandwidth systems such as oscilloscopes and data capture cards.

The frequency response of this particular amplifier can be seen in *Figure 1*.

**NEXT ISSUE:**

**Powering Applications Processors**

# Featured Products

## Single/Dual, High-Performance, Low-Power, 8-Bit, 1.5 GSPS ADC (3 GSPS DES mode)

The ADC08D1500 is the industry's lowest power, best performing, dual 8-bit 1.5 GSPS analog-to-digital converter. It simultaneously digitizes two signals to 8-bit resolution at sampling rates up to 1.5 GSPS or one signal at sampling rates up to 3 GSPS. Consuming a typical 1.8W at 3 GSPS from a single 1.9V supply, this device is guaranteed to have no missing codes over the full operating temperature range. The ADC081500 is the single converter conversion of the ADC08D1500.

The unique folding and interpolating architecture, fully differential comparator design, innovative design of the internal sample-and-hold amplifier, and the self-calibration scheme enable a very flat response of all dynamic parameters beyond Nyquist.



### Features

- 7.25 Effective number of bits (ENOB) at Nyquist, 1.5 GSPS (typ.)
- Bit error rate  $10^{-18}$  (typ.)
- Interleave mode on the ADC08D1500 for up to 3 GSPS sampling
- Choice of SDR or DDR output clocking
- Multiple ADC synchronization capability
- Serial interface for extended control
- Fine adjustment of input full-scale range and offset
- Single +1.9V ( $\pm 0.1V$ ) operation
- ADC08D1500 Consumes only 1.8W while running at 3 GSPS
- ADC081500 Consumes only 1.2W while running at 1.5 GSPS

The ADC08D1500 and the ADC081500 are well suited for a variety of applications including direct RF down conversion, digital oscilloscopes, satellite set-top boxes, communications systems, and test instrumentation. These converters are available in LQFP-128 packaging.

[www.national.com/pf/DC/ADC081500.html](http://www.national.com/pf/DC/ADC081500.html)  
[www.national.com/pf/DC/ADC08D1500.html](http://www.national.com/pf/DC/ADC08D1500.html)

[edge.national.com](http://edge.national.com)



## 1.2 GHz, Low Distortion Op Amp with Shutdown

The LMH6703 is a very wideband, DC coupled monolithic operational amplifier designed specifically for ultra-high resolution video systems as well as wide dynamic range systems requiring exceptional signal fidelity. Benefiting from National's current feedback architecture, the LMH6703 offers a practical gain range of  $\pm 1$  to  $\pm 10$  while providing stable operation without external compensation, even at unity gain. At a gain of +2, the LMH6703 supports ultra high resolution video systems with a 750 MHz  $2 V_{pp}$  -3 dB bandwidth.

With 12-bit distortion levels through 10 MHz ( $R_L = 100\Omega$ ), and a  $2.3 \text{ nV}/\sqrt{\text{Hz}}$  input referred noise, the LMH6703 is the ideal driver or buffer for high speed flash A/D and D/A converters. Wide dynamic range systems requiring exceptional signal fidelity and low distortion, such as in the test and measurement markets, can benefit from the performance of the LMH6703 amplifier.

### Features

- -3 dB Bandwidth ( $V_{OUT} = 0.5 V_{pp}$ ,  $A_V = +2$ ) 1.2 GHz
- Fast slew rate 4500 V/ $\mu\text{s}$
- 2nd/3rd Harmonic (20 MHz, SOT23-6) -69/-90 dBc
- Low noise  $2.3 \text{ nV}/\sqrt{\text{Hz}}$
- Low differential gain and phase 0.01%/0.02°

The LMH6703 is ideal for use in video switching and distribution, radar, communication receivers, and test and measurement applications, and is available in SOIC-8 and SOT23-6 packaging.

[www.national.com/pf/LM/LMH6703.html](http://www.national.com/pf/LM/LMH6703.html)

# High Performance Analog Front Ends

For a gain setting of 10 and a bandwidth of 500 MHz, the graph in *Figure 1* recommends the feedback resistor (RF1) to be 300 Ohms.

$$A_v = 1 + (R_f / R_g)$$

Therefore RG1 (the gain resistor) can be selected as 33 Ohms.

As an example, *Figure 2* below shows the LMH6703 in circuit with a differential amplifier.

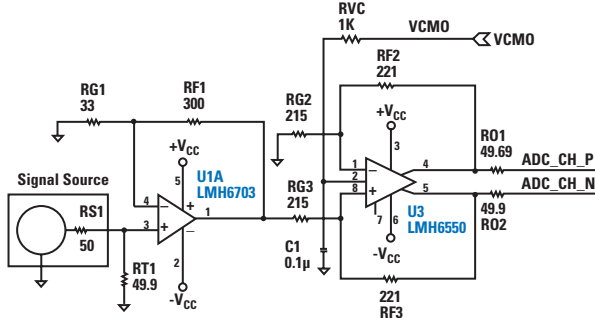

**Figure 2. Two Stage Amplifier Circuit Diagram**

Having provided the system with suitable levels of fixed gain for the DC signal path, the application may also require an AC-coupled mode. This is because a DC signal path will always be restricted by the gain bandwidth produced by the input amplifier. For data capture devices or communications channels that require very wide input bandwidth and low distortion, an AC signal path may be used. This allows the upper input frequency limit to extend beyond the DC signal path capability. This can be solved in a number of ways and the choice of which method will depend largely on the minimum input frequency and the required high frequency performance. For ultimate AC performance at high frequencies (200 MHz and above), balun transformers offer a good solution to achieve single-ended-to-differential conversion as they add very little distortion to the signal. The trade off is that baluns are lossy components which will attenuate the signal by a small amount (-1 to 2 dB) and they also have poor low-frequency performance. A balun-coupled signal path can be inserted into the circuit of *Figure 3* by using a single-pole RF relay to switch the single-ended output signal from the pre-amplifier into either the differential amplifier or the Balun Circuit. A 2nd Double Pole Double Throw

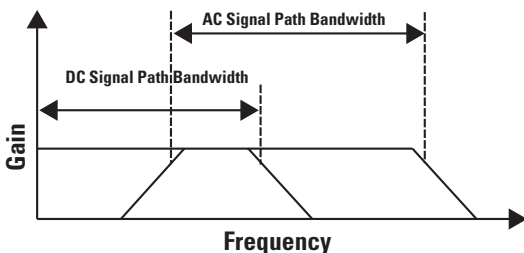

**Figure 3. Frequency Response of a System with Extended AC Signal Capability**

RF relay is also required to route the outputs of the balun and differential amplifier into the ADC inputs.

This circuit works well for high-end test and measurement equipment. But for cost-sensitive applications, the cost of RF signal relays becomes a burden on the system budget, especially if multiple channels are required. It is therefore advantageous for lower-speed systems to select a differential output operational amplifier that can be used for both AC- and DC-coupled modes, thus eliminating the balun circuit. Amplifiers suitable specifically for this task are beginning to gradually appear and are offering increasing performance in terms of bandwidth and THD figures. For an 8-bit 1 GSPS converter, a differential amplifier offering -50 dB THD figures at 500 MHz with a minimum bandwidth of 1 GHz, would be a good set of parameters to seek out. Good dynamic performance can be obtained from high-speed ADCs using off the shelf op-amp components in the front end design which greatly reduce the design time. The SINAD loss due to the amplifiers can be no more than 3 to 4 dB at the upper frequencies. The plot in *Figure 4* shows a FFT of a 198 MHz input signal buffered by a wide bandwidth differential output amplifier and sampled by an 8-bit ADC at 500 MSPS. The plot shows the amplifier has very low 2nd and

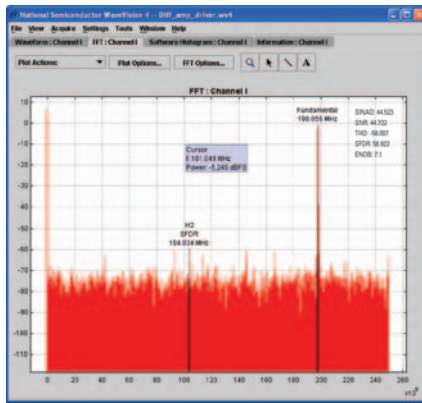

**Figure 4. FFT Plot of a 198 MHz Sine Wave Sourced by a High-Speed Differential Output Op Amp, Sampled at 500 MSPS by the ADC08D500**

3rd harmonic distortion at this frequency and enables the ADC to capture signals with noise and distortion figures that are comparable to the performance obtained from a dedicated AC-coupled signal path.

## Summary

Amplifier performance is continually being enhanced to deliver increased bandwidth and lower THD. With ADCs pushing well into the GSPS range, complimentary amplifiers that can interface to these converters will be in demand. Not only will system cost be reduced by eliminating circuit paths, the performance of the system will not be compromised and will allow designers to offer higher performance for lower cost, while reducing design time for front-end electronics. ■

The design of a differential output amplifier circuit was extensively covered in Signal Path Designer<sup>™</sup> #101, *A Walk Along the Signal Path*, available at [signalpath.national.com/designer](http://signalpath.national.com/designer)

## Featured Products

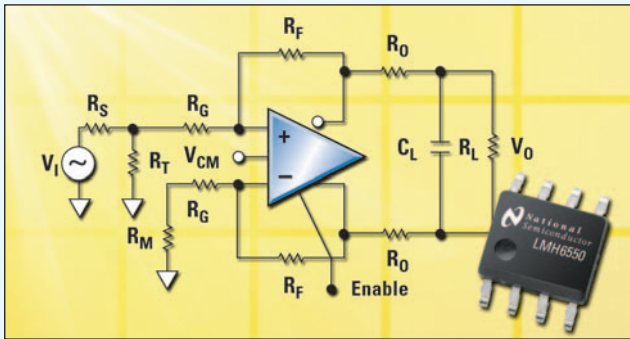

### Differential, High-Speed Op Amp

The LMH6550 is a high-performance voltage feedback differential amplifier. The fully differential topology allows balanced inputs to the ADCs and can be used as single-ended-to-differential or used as differential-to-differential. This amplifier has the high speed and low distortion necessary for driving high performance ADCs as well as the current handling capability to drive signals over balanced transmission lines such as CAT-5 data cables. The LMH6550 can handle a wide range of video and data formats.

With external gain set resistors, the LMH6550 can be used at any desired gain. Gain flexibility coupled with high speed makes this device suitable for use as an IF amplifier in high performance communications equipment.

#### Features

- 400 MHz, -3 dB Bandwidth ( $V_{OUT} = 0.5 V_{PP}$ )
- 90 MHz, 0.1 dB Bandwidth
- -92/-103 dB HD2/HD3 at 5 MHz
- 3000 V/ $\mu$ s Slew rate
- -68 dB Balance error ( $V_{OUT} = 1.0 V_{PP}$ , 10 MHz)
- 10 ns Shutdown/enable

The LMH6550 is ideal for use in applications requiring a differential A/D driver, video twisted pair, differential line driver, single end-to-differential converter, high-speed differential signaling, IF/RF amplifiers, or SAW filter buffer/drivers. It is available in the space-saving SOIC-8 and MSOP-8 packaging.

[www.national.com/pf/LM/LMH6550.html](http://www.national.com/pf/LM/LMH6550.html)

### High-Performance, Low-Power, Dual 8-Bit, 500 MSPS A/D Converter

The ADC08D500 is the industry's lowest power dual 8-bit 500 MSPS analog-to-digital converter. It simultaneously digitizes two signals to 8-bit resolution at sampling rates up to 500 MSPS or one signal at sampling rates up to 1 GSPS. Consuming a typical 1.4W at 500 MSPS from a single 1.9V supply, this device is guaranteed to have no missing codes over the full operating temperature range. Its best-in-class dynamic performance, linearity, and pulse response make it ideal for data acquisition systems. The low power consumption allows for small form factors (no heatsinks or fans required) and long battery life.



#### Features

- 7.5 Effective Number of Bits (ENOB) at Nyquist (typ)
- Bit error rate  $10^{-18}$  (typ)
- Single +1.9V ( $\pm 0.1V$ ) operation
- Interleave mode for 2x sampling rate
- Choice of SDR or DDR output clocking
- Multiple ADC synchronization capability
- Serial interface for extended control
- Fine adjustment of input full-scale range and offset

The ADC08D500 is ideal for use in direct RF down conversion, digital oscilloscopes, satellite set-top boxes, communications systems, and test instrumentation. This A/D converter is available in a thermally-enhanced exposed pad LQFP-128 and operates over the industrial (-40°C to +85°C) temperature range.

[www.national.com/pf/DC/ADC08D500.html](http://www.national.com/pf/DC/ADC08D500.html)