

LM77 9-bit + Sign Temperature Sensor Evaluation Kit Manual

1.0 General Description

The LM77 Evaluation Kit allows quick connection and evaluation of the LM77 9-bit plus Sign Temperature Sensor integrated circuit. The Evaluation Board connects to and derives all of its power from the parallel printer port of a PC. The software was written using Visual Basic 4.0 is compatible with Windows version 3.1 or later.

With the LM77 Evaluation board and software you can:

- Configure the LM77 register contents
- View the LM77 register contents
- Save LM77 temperature measurements in a file
- Quickly gain knowledge of the LM77 register operation

Figure 1 LM77 Evaluation Board

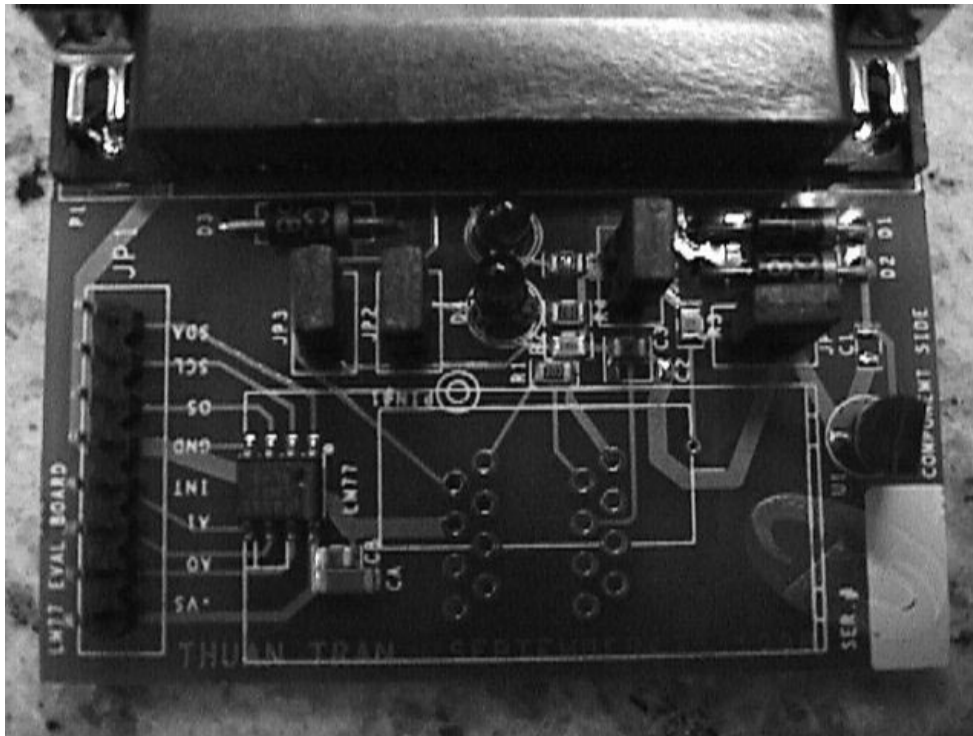

2.0 Installation

The LM77 Evaluation Kit comprises of the LM77 Evaluation board, a 3.5" diskette, and this instruction manual.

- Insert the floppy into the 3.5" floppy drive of the PC. Install the software in Windows by selecting Run and type in the name of the drive followed by "setup". For example type a:\setup.
- In setup select the drive you would like the software installed on. Disk space required for the software is 1MB.
- Make sure all the jumpers are installed on the demo board as shown in figure 1.
- Run the software. Select the parallel printer port address and the PC address of the demo board. The default I2C address is 100 1000 with JP3 and JP4 installed.

- Connect the board to the parallel printer port of the PC directly or through a cable not longer than 3 feet.
- Press the ON button on the screen. The software will then report the state of all the registers in the LM77.

3.0 LM77 Evaluation Board Schematic

The LM77 Demo Board schematic is shown at the end of this document. The software was pre-configured to run with all of the jumpers installed.

Table 1 Jumper Functions

Jumper	Function
JP1	Mapped to the corresponding pin on the LM77 (see Table 2)
JP2	Monitoring LED connection to pin OS/T_CRIT_A pin when short is installed.
JP3	Connects A0 to logic 0 when short is installed; connects A0 to logic 1 when short is not present.
JP4	Connects A1 to logic 0 when short is installed; connects A1 to logic 1 when short is not present.
JP5	Monitoring LED connection to INT pin when short is installed.

The LM77 comes with shorting bars across 2 pin headers JP2, JP3, JP4, JP5.

Table 2 JP1 Description

Pin Number	Description
1	SDA
2	SCL
3	Label OS on Board but maps to T_CRIT_A pin on LM77
4	GND
5	A1
6	A0
7	INT
8	+Vs

4.0 LM77 Evaluation Board Bill of Materials

<u>Item</u>	<u>Qty</u>	<u>Reference</u>	<u>Description</u>
1	2	C1, CB	0.1 uF, 0805, 25V, +80%-20%
2	1	CA	10 uF, 1206
3	2	D1, D2	1N5817 or 1N5712,TH
4	1	D3	1N5817 or 1N5712,TH
5	2	D4, D5	RED LED, HLMP K150, TH
6	1	JP1	HEADER 8X1, TH
7	4	JP2, JP3, JP4, JP5	HEADER 2X1, TH
8	1	P1	DB25, MALE, RIGHT ANGLE
9	3	R1, R4, R5	2K, 1/8 W, 0805, 5%
10	2	R2, R3	100K, 1/8 W, 0805, 5%
11	1	U1	LP2950CZ-3.3, TH
12	1	U2	LM77
13	4	JP2, JP3, JP4, JP5	JUMPERS

NOTE, TH = Through hole

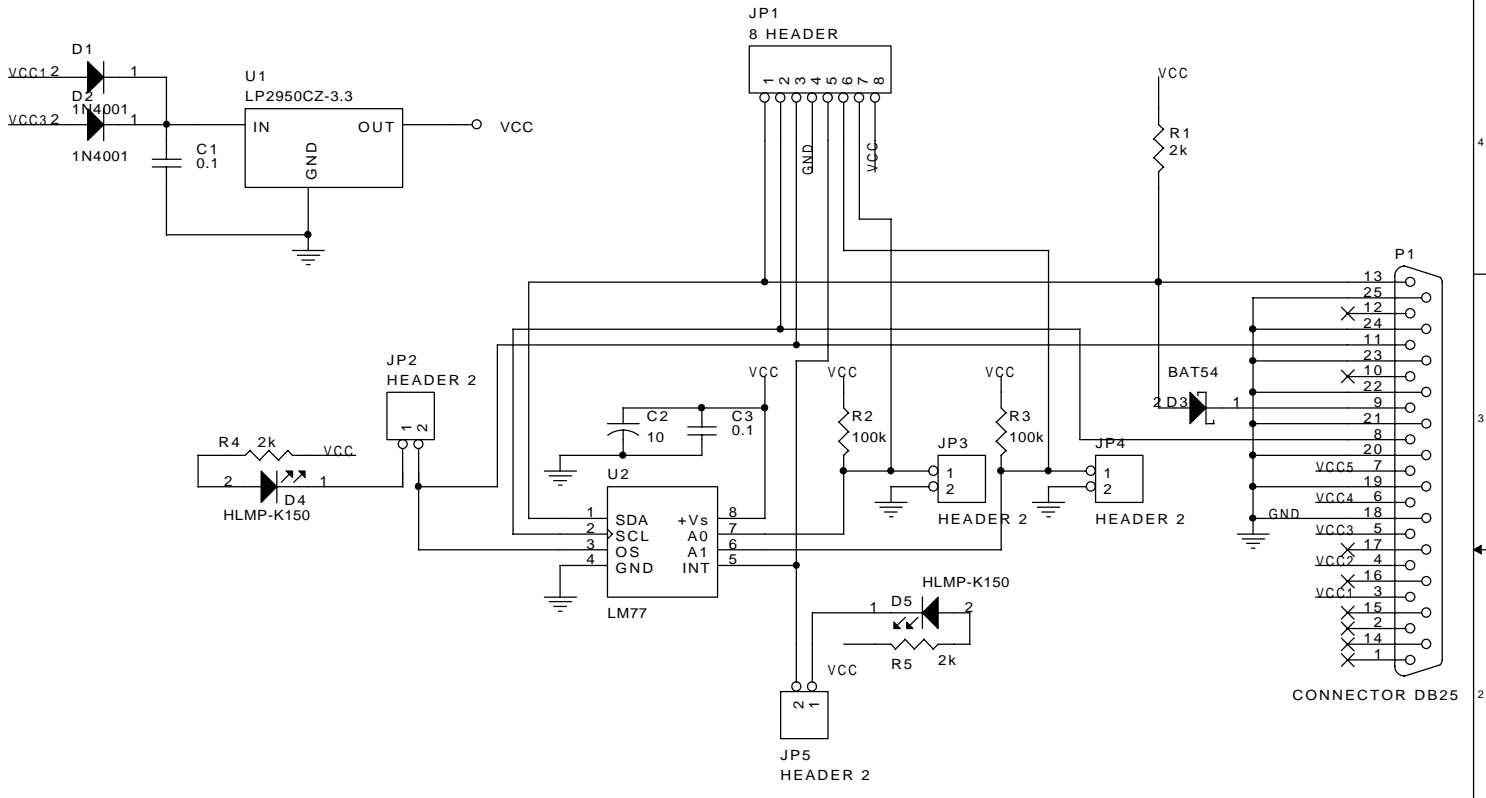

Title		
LM77 Small DEMO BOARD		
Size	Document Number	Rev
A	0	1.0
Date:	Wednesday, July 02, 1997	Sheet 1 of 1